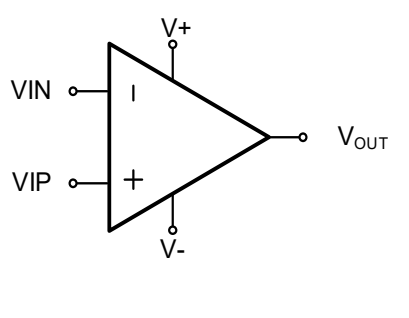

OSU7331 OSU7393 OSU7339

General-Purpose Low-Voltage Open-Drain Output Comparator

1 Features	2 Application
<ul style="list-style-type: none"> - Supply range: +1.8V to +5.5V - Low supply current 50μA per channel at Vs =5V - Input common-Mode voltage range includes ground - Operating temperature from -40°C to +125°C - Low output saturation voltage 170mV typical - Open-Drain output for maximum flexibility 	<ul style="list-style-type: none"> - Hysteresis comparators - Oscillators - Window comparators - Industrial equipment - Test and measurement

3 Description	Circuit Diagram
<p>The OSU7331 and OSU7393 is the single and dual comparator version, the OSU7339 is quad comparator version, and both are open-drain output comparators for maximum flexibility. It can operate from 1.8V to 5.5V, and have low power consuming 50μA (TYP) per channel.</p> <p>The OSU7331, OSU7393 and OSU7339 are the most cost-effective solutions for applications where low voltage operation, low power and space saving are the primary specifications in circuit design for portable consumer products.</p> <p>The OSU7331, OSU7393 and OSU7339 are available in Green SOT23-5, SC70-5, SOP8, MSOP8, TSSOP8, SOP14 and TSSOP14 packages. It operates over an ambient temperature range of -40°C to +125°C.</p>	

4 Device Summary, Pin and Packages

Table. 5-1. Device Summary⁽¹⁾

Serial Name	Part Name	Package	Body Size (Nom)	Marking ⁽²⁾	MSL ⁽³⁾	Package Qty
OSU7331	OSU7331S5	SOT23-5	2.90mm×1.60mm×1.10mm	OSU7331 XXXXX	3	Tape and Reel,3000
OSU7331	OSU7331C5	SC70-5	2.10mm×1.25mm×1.00mm	OSU7331 XXXXX	3	Tape and Reel,3000
OSU7393	OSU7393P8	SOP8	4.90mm×3.90mm×1.75mm	OSU7393 XXXXXXXX	3	Tape and Reel,4000
OSU7393	OSU7393M8	MSOP8	3.00mm×3.00mm×1.10mm	OSU7393 XXXXXXXX	3	Tape and Reel,4000
OSU7393	OSU7393T8	TSSOP8	3.00mm×4.40mm×1.10mm	OSU7393 XXXXXXXX	3	Tape and Reel,4000
OSU7339	OSU7339PD	SOP14	8.65mm×3.90mm×1.75mm	OSU7339 XXXXXXXX	3	Tape and Reel,4000
OSU7339	OSU7339TD	TSSOP14	5.00mm×4.40mm×1.20mm	OSU7339 XXXXXXXX	3	Tape and Reel,4000

(1) For all available packages, please contact product sales

(2) There may be additional marking, which relates to the lot trace code information (data code and vendor code), the logo or the environmental category on the device.

(3) MSL, The Moisture Sensitivity Level rating according to the JEDEC industry standard classifications.

(4) "XXXXX" in Marking will be appeared as the batch code.

4 Device Summary, Pin and Packages(Continued)

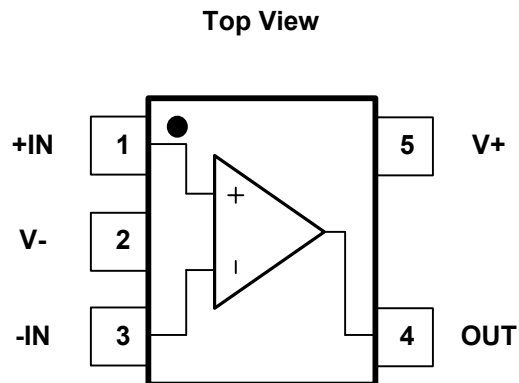

Fig.5-1. OSU7331: S5 (SOT23-5) Package
OSU7331: C5 (SC70-5) Package

Table. 5-2. Pin Definition

Pin		I/O	Description
Name	S5 C5		
+IN	1	I	Noninverting input
V-	2	-	Negative (lowest) power supply
-IN	3	I	Inverting input
OUT	4	O	Output
V+	5	-	Positive (highest) power supply

*It is suggested to leave the unconnected pins floating.

4 Device Summary, Pin and Packages(Continued)

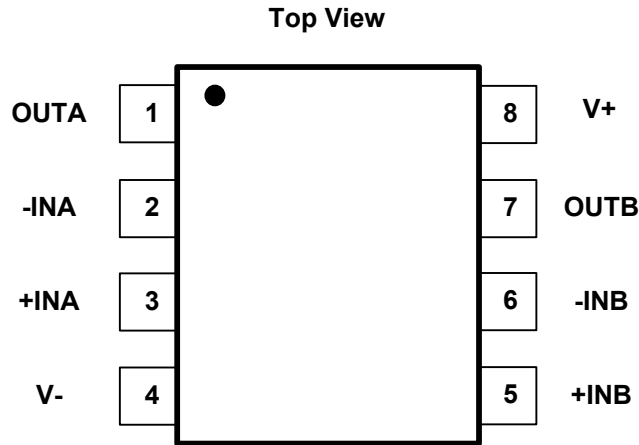

Fig.5-2. OSU7393: P8 (SOP8) Package

OSU7393: M8 (MSOP8) Package

OSU7393: T8 (TSSOP8) Package

Table. 5-3. Pin Definition

Pin		I/O	Description
Name	P8 M8 T8		
OUTA	1	O	Output, channel A
-INA	2	I	Inverting input, channel A
+INA	3	I	Noninverting input, channel A
V-	4	-	Negative (lowest) power supply
+INB	5	I	Noninverting input, channel B
-INB	6	I	Inverting input, channel B
OUTB	7	O	Output, channel B
V+	8	-	Positive (highest) power supply

*It is suggested to leave the unconnected pins floating.

4 Device Summary, Pin and Packages(Continued)

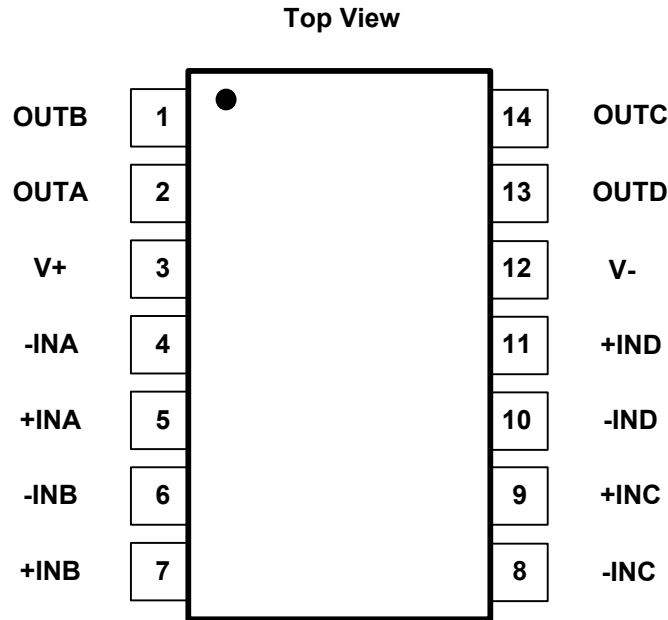

Fig.5-3. OSU7339:PD (SOP14) Package
OSU7339:TD (TSSOP14) Package

Table. 5-4. Pin Definition

Pin		I/O	Description
Name	TD PD		
OUTB	1	O	Output, channel B
OUTA	2	O	Output, channel A
V+	3	P	Positive (highest) power supply
-INA	4	I	Inverting input, channel A
+INA	5	I	Noninverting input, channel A
-INB	6	I	Inverting input, channel B
+INB	7	I	Noninverting input, channel B
-INC	8	I	Inverting input, channel C
+INC	9	I	Noninverting input, channel C
-IND	10	I	Inverting input, channel D
+IND	11	I	Noninverting input, channel D
V-	12	P	Negative (lowest) power supply
OUTD	13	O	Output, channel D
OUTC	14	O	Output, channel C

*It is suggested to leave the unconnected pins floating.

5 Voltage, Temperature, ESD and Thermal Ratings

5.1 Absolute Maximum Ratings⁽¹⁾

Parameters		Min.	Max.	Unit
Voltage	Supply, $V_s=(V+) - (V-)$		6.5	V
	Input pin (IN+, IN-) ⁽²⁾	(V-)-0.3	(V+) +0.3	
	Signal output pin ⁽³⁾	(V-)-0.3	(V+) +0.3	
Current	Signal input pin (IN+, IN-) ⁽²⁾	-10	10	mA
	Signal output pin ⁽³⁾	-55	55	mA
	Output short-circuit ⁽⁴⁾	Continuous		
Temperature	Operating range, T_A	-40	125	°C

(1) Stresses above these ratings may cause permanent damage. Exposure to absolute maximum conditions for extended periods may degrade device reliability. These are stress ratings only, and functional operation of the device at these or any other conditions beyond those specified is not implied.

(2) Input terminals are diode-clamped to the power-supply rails. Input signals that can swing more than 0.5V beyond the supply rails should be current-limited to 10mA or less.

(3) Output terminals are diode-clamped to the power-supply rails. Output signals that can swing more than 0.5V beyond the supply rails should be current-limited to ± 55 mA or less.

(4) Short-circuit from output to VCC can cause excessive heating and eventual destruction.

5.2 ESD Ratings

ESD		Value	Unit	
V(ESD)	Electrostatic discharge	Human-Body Model (HBM) ⁽¹⁾	8 K	V
		Charged-Device Model (CDM) ⁽²⁾	2 K	V

(1) JEDEC document JEP155 states that 500-V HBM allows safe manufacturing with a standard ESD control process.

(2) JEDEC document JEP157 states that 250-V CDM allows safe manufacturing with a standard ESD control process.

5.3 Recommended Operating Conditions

Over operating free-air temperature range (unless otherwise noted)

Parameters		MIN	NOM	MAX	UNIT
Supply voltage , $V_s=(V+) - (V-)$	Single-supply	1.8		5.5	V
	Dual-supply	± 0.9		± 2.75	

5.4 Thermal Information

Package Type	θ_{JA}	θ_{JC}	Unit
SC70-5	400	150	°C/W
SOT23-5	250	81	°C/W
MSOP8	210	45	°C/W
SOP8	158	43	°C/W
TSSOP8	191	44	°C/W
TSSOP14	180	35	°C/W
SOP14	120	36	°C/W

6 Electrical Specifications

6.1 Electrical characteristics(Vs=5.0V)

At TA=+25°C, VCM=Vs/2.(unless otherwise noted)

Parameter		Conditions	OSU7331/OSU7393/OSU7339			Units
			Min	Typ	Max	
Power Supply						
Vs	Operating Voltage Range		1.8		5.5	V
IQ	Quiescent Current/per Channel			50	100	μA
PSRR	Power-Supply Rejection Ratio	Vs=1.8V to 5.5V, VCM=(V)+0.5V		57		dB
Input						
Vos	Input Offset Voltage		-4.5	±1.1	4.5	mV
ΔVos/ΔT	Input Offset Voltage Drift	VCM=Vs/2, -40°C≤TA≤125°C		3		μV/°C
IB	Input Bias Current			15		pA
Ios	Input Offset Current			15		pA
VCM	Common-Mode Voltage Range	TA=-40°C to 125°C	(V-)-0.1		(V+)+0.1	V
CMRR	Common-Rejection Ratio	VCM=-0.1 to 5.6V		67		dB
Output						
VSAT	Saturation Voltage	Io≤4mA		170	350	mV
VOH	Output Pull-up Voltage Range				5.6	V
Io	Output Current(sinking)	Vo≤1.5V		30		mA
ILEAK	Output Leakage Current			0.01	10	nA
Switching						
TPHL	Propagation Delay H To L	RPU=5.1KΩ , Overdrive=10mV		205		ns
		RPU=5.1KΩ , Overdrive=100mV		190		
TPLH	Propagation Delay L To H	RPU=5.1KΩ , Overdrive=10mV		520		
		RPU=5.1KΩ , Overdrive=100mV		475		
TF	Fall Time	RPU=5.1KΩ , Overdrive=100mV		24		ns

6 Electrical Specifications(Continued)

6.2 Electrical characteristics(Vs=2.7V)

At TA=+25°C, VCM=Vs/2.(unless otherwise noted)

Parameter	Conditions	OSU7331/OSU7393/OSU7339			Units	
		Min	Typ	Max		
Power Supply						
Vs	Operating Voltage Range	1.8		5.5	V	
IQ	Quiescent Current/per Channel		48	80	μA	
PSRR	Power-Supply Rejection Ratio	Vs=1.8V to 5.5V, VCM=(V)+0.5V		57	dB	
Input						
Vos	Input Offset Voltage	-4.5	1.1	4.5	mV	
ΔVos/ΔT	Input Offset Voltage Drift	VCM=Vs/2, -40°C≤TA≤125°C		3	μV/°C	
IB	Input Bias Current		15		pA	
Ios	Input Offset Current		15		pA	
VCM	Common-Mode Voltage Range	TA=-40°C to 125°C		(V-)-0.1	(V+)+0.1	V
CMRR	Common-Rejection Ratio	VCM=-0.1 to 2.8V		67	dB	
Output						
VSAT	Saturation Voltage	Io≤2.2mA		130	mV	
VOH	Output Pull-up Voltage Range			5.6	V	
Io	Output Current(sinking)	Vo≤1.5V		15	mA	
ILEAK	Output Leakage Current		0.01	10	nA	
Switching						
TPHL	Propagation Delay H To L	RPU=5.1KΩ, Overdrive=10mV		192	ns	
		RPU=5.1KΩ, Overdrive=100mV		185		
TPLH	Propagation Delay L To H	RPU=5.1KΩ, Overdrive=10mV		486		
		RPU=5.1KΩ, Overdrive=100mV		483		
TF	Fall Time	RPU=5.1KΩ, Overdrive=100mV		30	ns	

6 Electrical Specifications(Continued)

6.3 Electrical characteristics(Vs=1.8V)

At TA=+25°C, VCM=Vs/2.(unless otherwise noted)

Parameter		Conditions	OSU7331/OSU7393/OSU7339			Units
			Min	Typ	Max	
Power Supply						
Vs	Operating Voltage Range		1.8		5.5	V
IQ	Quiescent Current/per Channel			40	70	μA
PSRR	Power-Supply Rejection Ratio	Vs=1.8V to 5.5V, VCM=(V)+0.5V		57		dB
Input						
Vos	Input Offset Voltage		-4.5	±1.1	4.5	mV
ΔVos/ΔT	Input Offset Voltage Drift	VCM=Vs/2, -40°C≤TA≤125°C		3		μV/°C
IB	Input Bias Current			15		pA
Ios	Input Offset Current			15		pA
VCM	Common-Mode Voltage Range	TA=-40°C to 125°C	(V-)-0.1		(V+)+0.1	V
CMRR	Common-Rejection Ratio	VCM=-0.1 to 1.9V		67		dB
Output						
VSAT	Saturation Voltage	Io≤1.5mA		130		mV
VOH	Output Pull-up Voltage Range				5.6	V
Io	Output Current(sinking)	Vo≤0.8V		5.8		mA
ILEAK	Output Leakage Current			0.01	10	nA
Switching						
TPHL	Propagation Delay H To L	RPU=5.1KΩ , Overdrive=10mV		271		ns
		RPU=5.1KΩ, Overdrive=100mV		258		
TPLH	Propagation Delay L To H	RPU=5.1KΩ , Overdrive=10mV		520		
		RPU=5.1KΩ, Overdrive=100mV		487		
TF	Fall Time	RPU=5.1KΩ, Overdrive=100mV		60		ns

7 Typical Characteristics

At TA=+25°C, VCM=Vs/2. (unless otherwise noted)

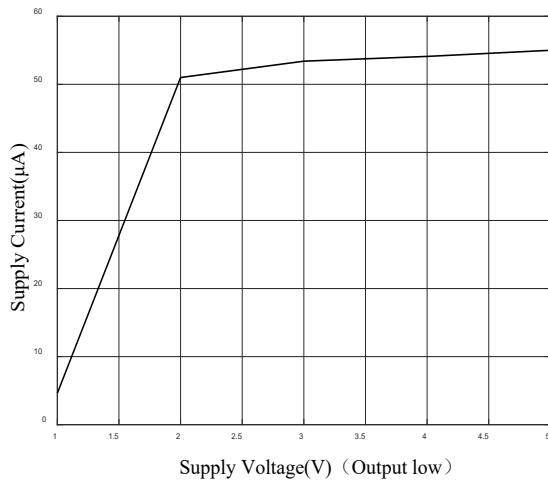

Fig.7-1. Supply Current vs Supply Voltage Output Low

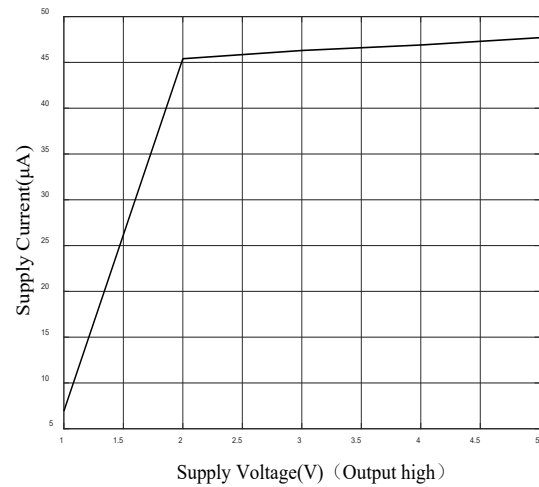

Fig.7-2. Supply Current vs Supply Voltage Output High

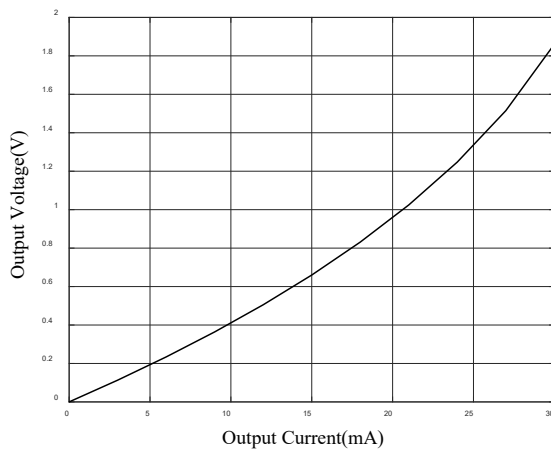

Fig.7-3. Output Voltage vs Output Current

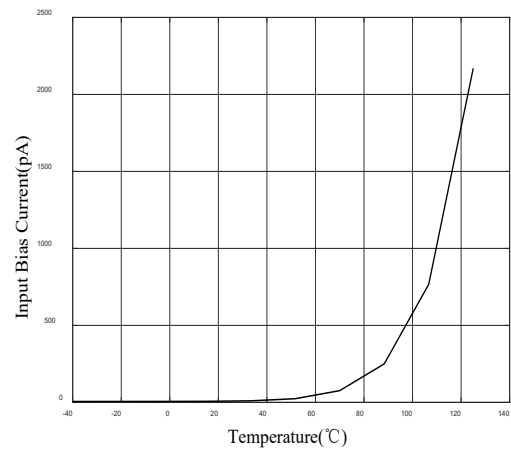

Fig.7-4. Input bias current vs temperature

8 Detailed Description

The OSU7331, OSU7393 and OSU7339 family of comparators can operate up to 5.5V on the supply pin. This standard device has proven ubiquity and versatility across a wide range of applications. This is due to its low power and high speed. The open-drain output allows the user to configure the output's logic low voltage (VOL) and can be utilized to enable the comparator to be used in AND functionality.

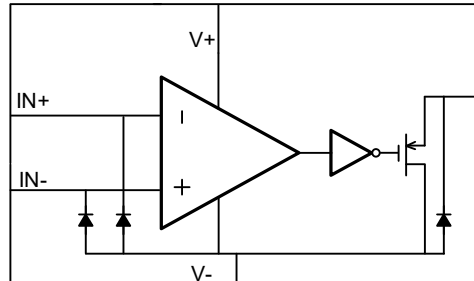

Fig.8-1. Funtional Block Diagram

9 Application Note

OSU7331, OSU7393 and OSU7339 will typically be used to compare a single signal to a reference or two signals against each other. Many users take advantage of the open drain output (logic high with pull-up) to drive the comparison logic output to a logic voltage level to an MCU or logic device.

For fast response and comparison applications with noisy or AC inputs, it is recommended to use a bypass capacitor on the supply pin to reject any variation on the supply voltage. This variation causes temporary fluctuations in the comparator's input common mode range and create an inaccurate comparison.

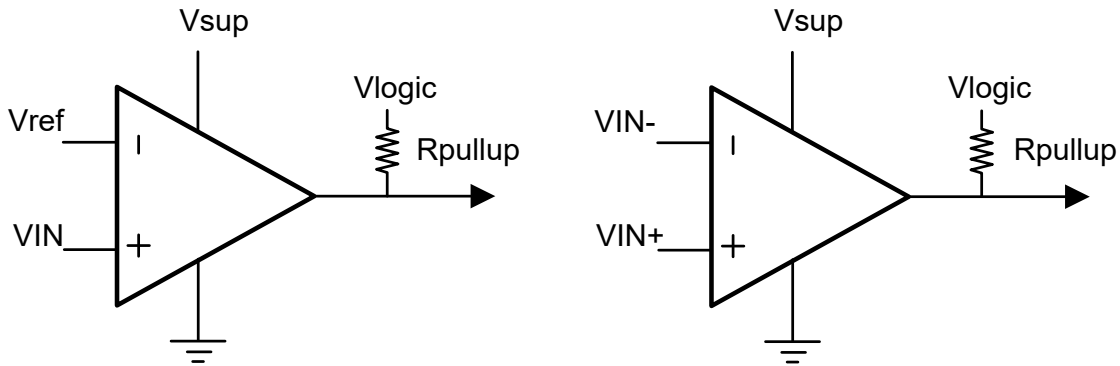
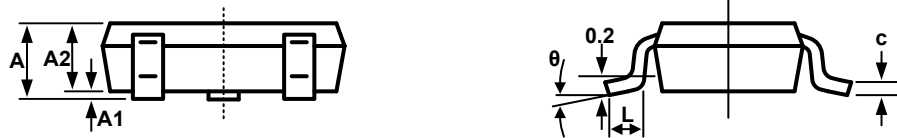
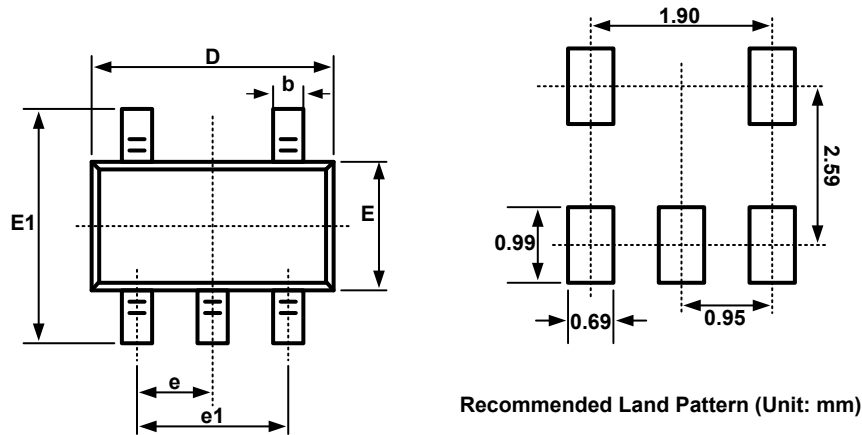

Fig.9-1. Typical Application Schematic

10 Package Outline Dimension

SOT23-5



Symbol	Dimensions in Millimeters		Dimensions in Inches	
	Min.	Max.	Min.	Max.
A	1.050	1.250	0.041	0.049
A1	0.000	0.100	0.000	0.004
A2	1.050	1.150	0.041	0.045
b	0.300	0.500	0.012	0.020
c	0.100	0.200	0.004	0.008
D	2.820	3.020	0.111	0.119
E	1.500	1.700	0.059	0.067
E1	2.650	2.950	0.104	0.116
e	0.950(BSC)		0.037(BSC)	
e1	1.800	2.000	0.071	0.079
L	0.300	0.600	0.012	0.024
θ	0°	8°	0°	8°

10 Package Outline Dimension(Continued)

SC70-5

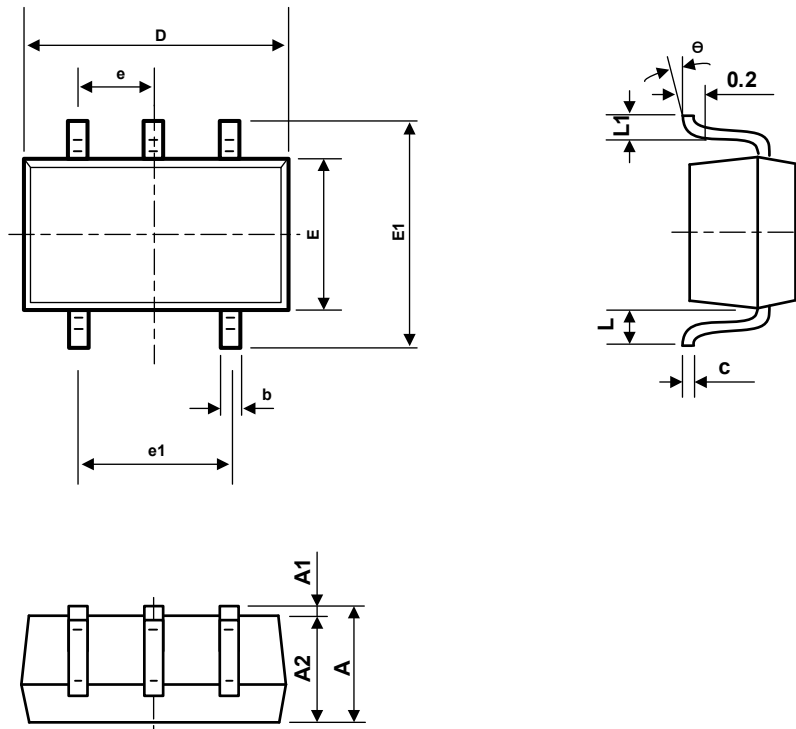

Symbol	Dimensions in Millimeters		Dimensions in Inches	
	Min.	Max.	Min.	Max.
A	0.900	1.100	0.035	0.043
A1	0.000	0.100	0.000	0.004
A2	0.900	1.000	0.035	0.039
b	0.150	0.350	0.006	0.014
c	0.110	0.175	0.004	0.007
D	2.000	2.200	0.079	0.087
E	1.150	1.350	0.045	0.053
E1	2.150	2.450	0.085	0.096
e	0.650TYP		0.026TYP	
e1	1.200	1.400	0.047	0.055
L	0.525REF		0.021REF	
L1	0.260	0.460	0.010	0.018
θ	0°	8°	0°	8°

10 Package Outline Dimension(Continued)

SOP8

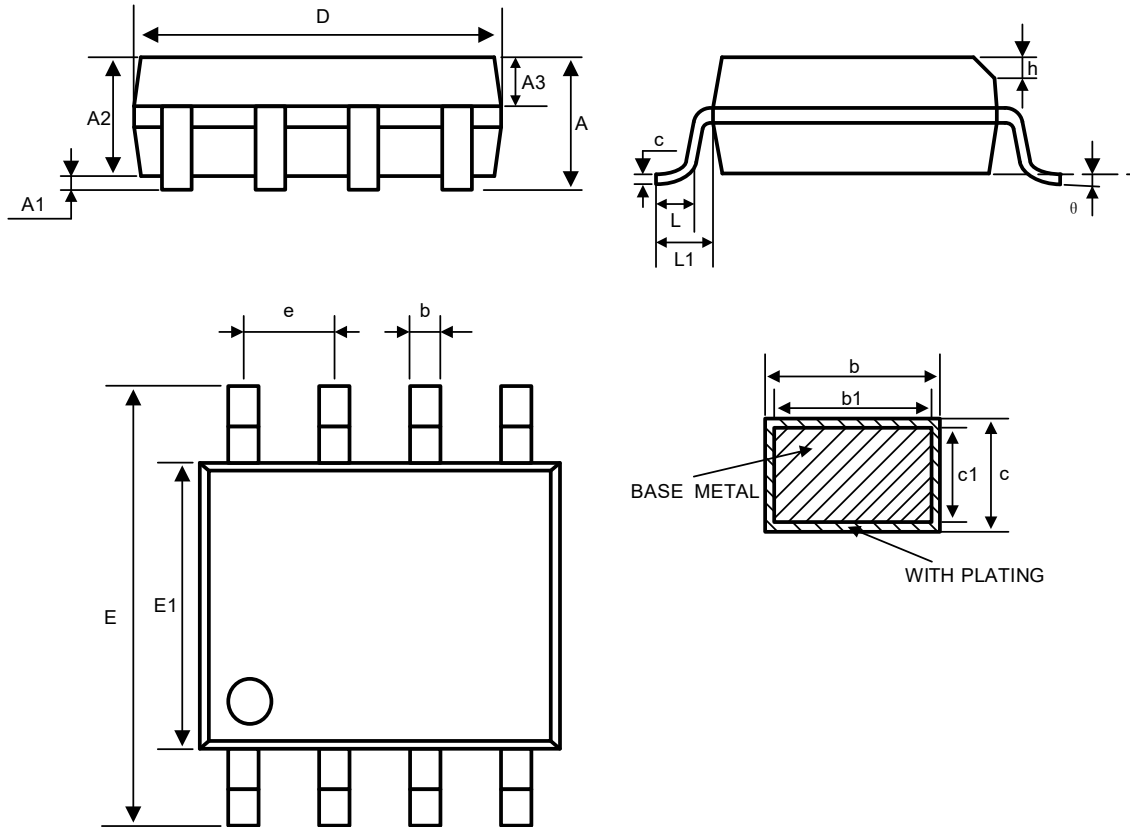

Symbol	Dimensions in Millimeters			Dimensions in Inches		
	Min.	Nom.	Max.	Min.	Nom.	Max.
A	—	—	1.75	—	—	0.069
A1	0.10	—	0.225	0.004	—	0.009
A2	1.30	1.40	1.50	0.051	0.055	0.059
A3	0.60	0.65	0.70	0.024	0.026	0.028
b	0.39	—	0.47	0.015	—	0.019
b1	0.38	0.41	0.44	0.015	0.016	0.017
c	0.20	—	0.24	0.008	—	0.009
c1	0.19	0.20	0.21	0.007	0.008	0.008
D	4.80	4.90	5.00	0.189	0.193	0.197
E	5.80	6.00	6.20	0.228	0.236	0.244
E1	3.80	3.90	4.00	0.150	0.154	0.157
e	1.27BSC			0.05BSC		
h	0.25	—	0.50	0.010	—	0.020
L	0.50	—	0.80	0.020	—	0.031
L1	1.05REF			0.041REF		
theta	0	—	8°	0	—	8°

10 Package Outline Dimension(Continued)

MSOP8

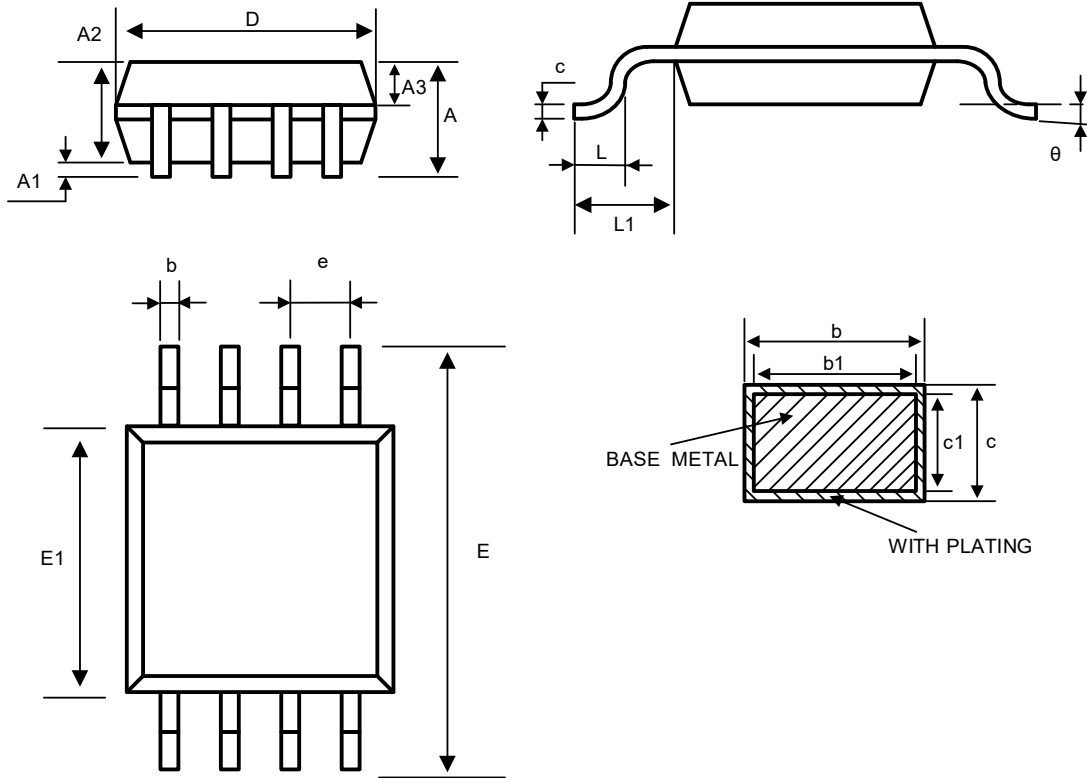

Symbol	Dimensions in Millimeters			Dimensions in Inches		
	Min.	Nom.	Max.	Min.	Nom.	Max.
A	—	—	1.10	—	—	0.043
A1	0.05	—	0.15	0.002	—	0.006
A2	0.75	0.85	0.95	0.030	0.033	0.037
A3	0.30	0.35	0.40	0.012	0.014	0.016
b	0.28	—	0.36	0.011	—	0.014
b1	0.27	0.30	0.33	0.011	0.012	0.013
c	0.15	—	0.19	0.006	—	0.007
c1	0.14	0.15	0.16	0.006	0.006	0.006
D	2.90	3.00	3.10	0.114	0.118	0.122
E	4.70	4.90	5.10	0.185	0.193	0.201
E1	2.90	3.00	3.10	0.114	0.118	0.122
e	0.65BSC			0.026BSC		
L	0.40	—	0.70	0.016	—	0.028
L1	0.95REF			0.037REF		
θ	0	—	8°	0	—	8°

10 Package Outline Dimension(Continued)

TSSOP8

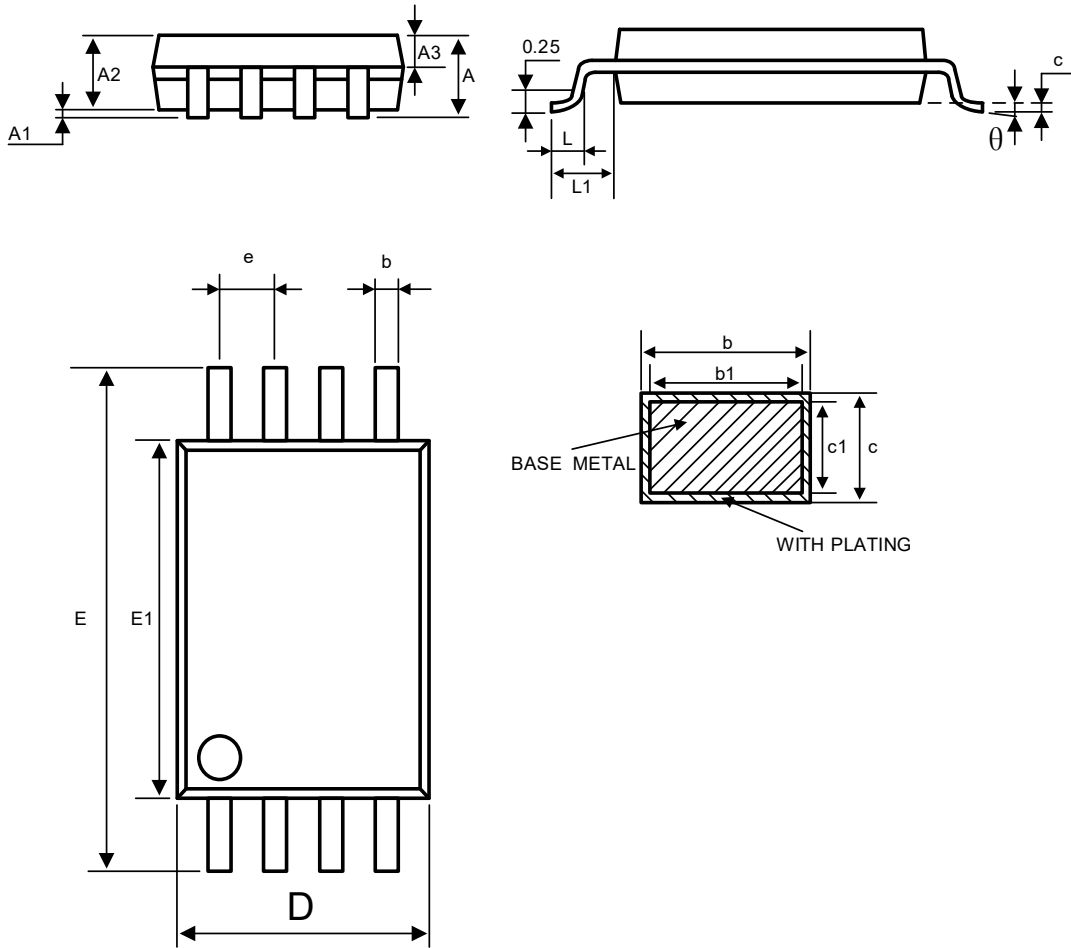

Symbol	Dimensions in Millimeters			Dimensions in Inches		
	Min.	Nom.	Max.	Min.	Nom.	Max.
A	—	—	1.20	—	—	0.047
A1	0.05	—	0.15	0.002	—	0.006
A2	0.90	1.00	1.05	0.035	0.039	0.041
A3	0.39	0.44	0.49	0.015	0.017	0.019
b	0.20	—	0.28	0.008	—	0.011
b1	0.19	0.22	0.25	0.007	0.009	0.010
c	0.13	—	0.17	0.005	—	0.007
c1	0.12	0.13	0.14	0.005	0.005	0.006
D	2.90	3.00	3.10	0.114	0.118	0.122
E1	4.30	4.40	4.50	0.169	0.173	0.177
E	6.20	6.40	6.60	0.244	0.251	0.260
e	0.65BSC			0.026BSC		
L	0.45	—	0.75	0.018	—	0.030
L1	1.00REF			0.039REF		
θ	0	—	8°	0	—	8°

10 Package Outline Dimension(Continued)

SOP14

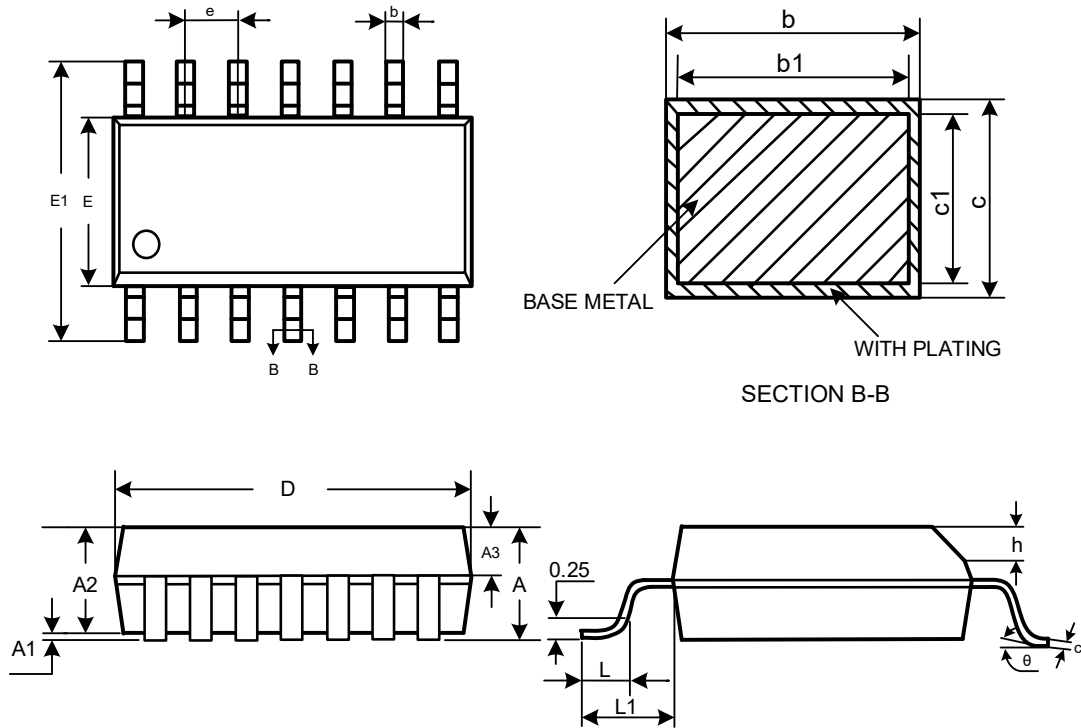

Symbol	Dimensions in Millimeters			Dimensions in Inches		
	Min	Nom	Max	Min	Nom	Max
A	—	—	1.75	—	—	0.069
A1	0.10	—	0.225	0.004	—	0.009
A2	1.30	1.40	1.50	0.051	0.055	0.059
A3	0.60	0.65	0.70	0.024	0.026	0.028
b	0.39	—	0.47	0.015	—	0.019
b1	0.38	0.41	0.44	0.015	0.016	0.017
c	0.20	—	0.24	0.008	—	0.009
c1	0.19	0.20	0.21	0.007	0.008	0.008
D	8.55	8.65	8.75	0.337	0.341	0.344
E1	5.80	6.00	6.20	0.228	0.236	0.244
E	3.80	3.90	4.00	0.150	0.154	0.157
e	1.27BSC			0.05BSC		
h	0.25	—	0.50	0.010	—	0.020
L	0.50	—	0.80	0.020	—	0.031
L1	1.05REF			0.041REF		
θ	0	—	8°	0	—	8°

10 Package Outline Dimension(Continued)

TSSOP14

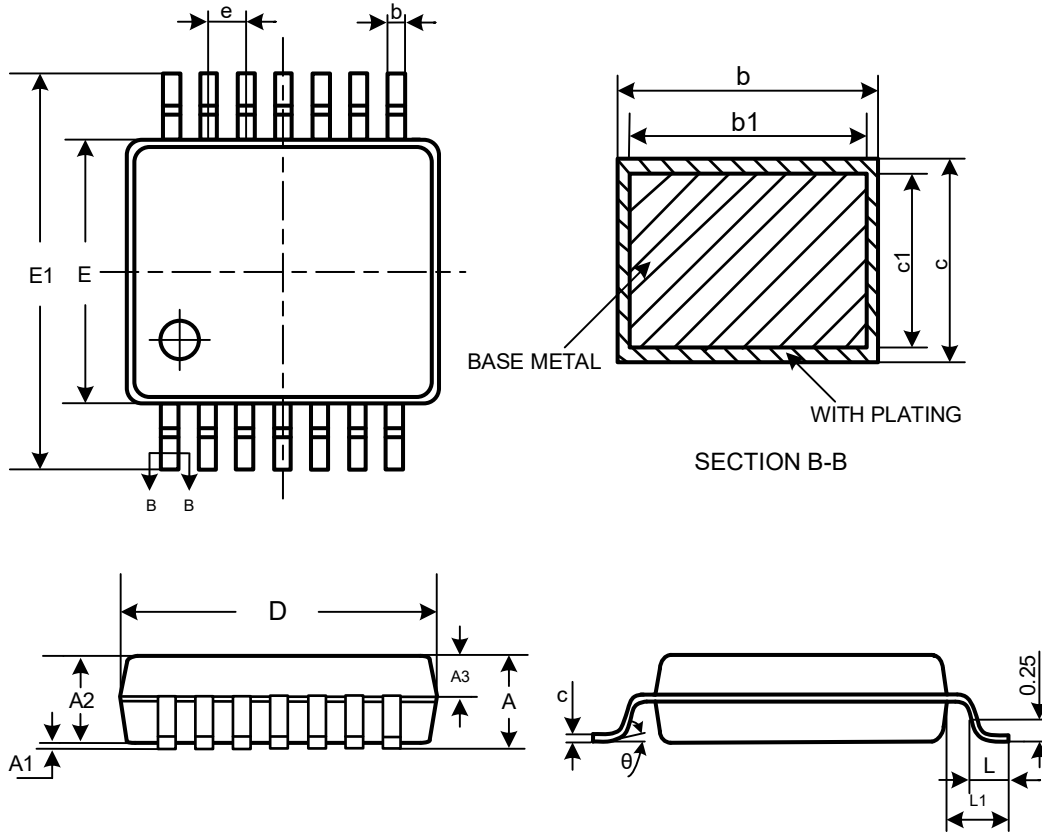

Symbol	Dimensions in Millimeters			Dimensions in Inches		
	Min	Nom	Max	Min	Nom	Max
A	—	—	1.20	—	—	0.047
A1	0.05	—	0.15	0.002	—	0.006
A2	0.90	1.00	1.05	0.035	0.039	0.041
A3	0.39	0.44	0.49	0.015	0.017	0.019
b	0.20	—	0.28	0.008	—	0.011
b1	0.19	0.22	0.25	0.007	0.009	0.010
c	0.13	—	0.17	0.005	—	0.007
c1	0.12	0.13	0.14	0.005	0.005	0.006
D	4.90	5.00	5.10	0.193	0.197	0.201
E	4.30	4.40	4.50	0.169	0.173	0.177
E1	6.20	6.40	6.60	0.244	0.252	0.260
e	0.65BSC			0.026BSC		
L	0.45	0.60	0.75	0.018	0.024	0.030
L1	1.00BCS			0.039BSC		
θ	0	—	8°	0	—	8°

11 Tape and Reel Information

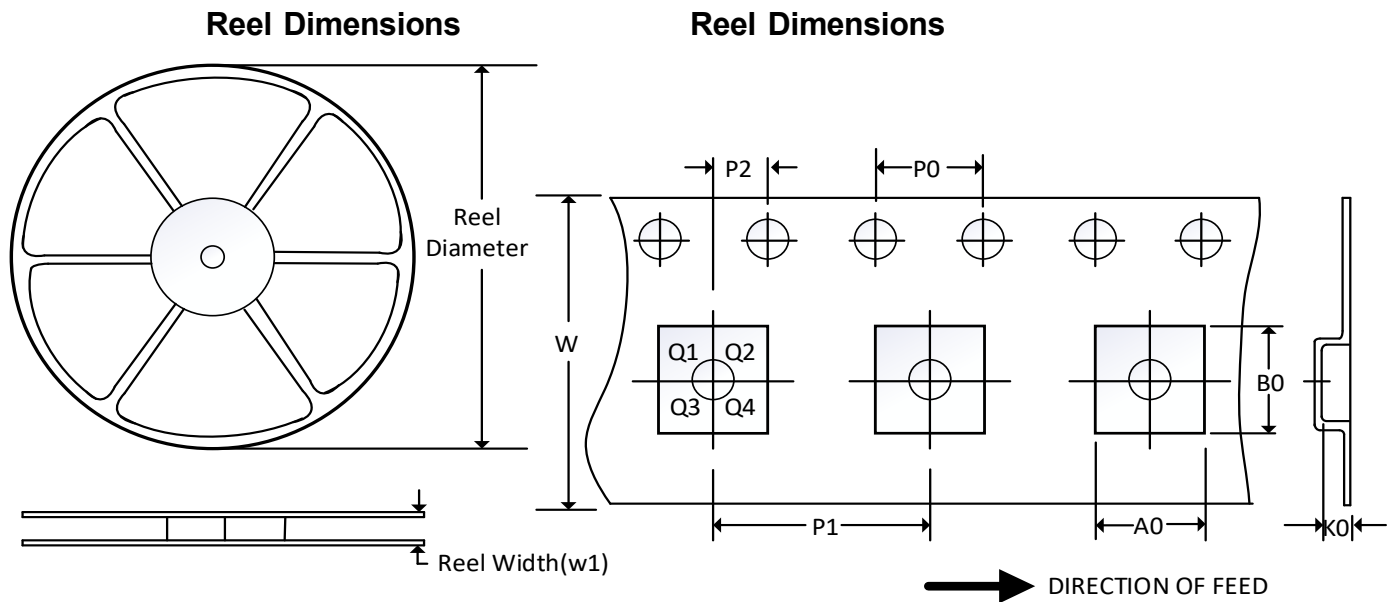

NOTE: The picture is only for reference. Please make the object as the standard.

Key Parameter List of Tape and Reel

Package Type	Reel Diameter	Reel Width (mm)	A0 (mm)	B0 (mm)	K0 (mm)	P0 (mm)	P1 (mm)	P2 (mm)	W (mm)	Pin1 Quadrant
SOT23-5	7"	9.5	3.20	3.20	1.40	4.0	4.0	2.0	8.0	Q3
SC70-5	7"	9.5	2.25	2.55	1.20	4.0	4.0	2.0	8.0	Q3
TSSOP14	13"	12.4	6.95	5.60	1.20	4.0	8.0	2.0	12.0	Q1
SOP8	13"	12.4	6.40	5.40	2.10	4.0	8.0	2.0	12.0	Q1
MSOP8	13"	12.4	5.20	3.30	1.50	4.0	8.0	2.0	12.0	Q1
TSSOP8	13"	12.4	6.90	3.45	1.65	4.0	8.0	2.0	12.0	Q1
SOP14	13"	16.4	6.60	9.30	2.10	4.0	8.0	2.0	16.0	Q1

NOTE:

1. All dimensions are nominal.
2. Plastic or metal protrusions of 0.15mm maximum per side are not included.

Legal Disclaimer

The information given in this document shall in no event be regarded as a guarantee of conditions or characteristics. With respect to any examples or hints given herein, any typical values stated herein and/or any information regarding the application of the device, Oriental Semiconductor hereby disclaims any and all warranties and liabilities of any kind, including without limitation, warranties of non-infringement of intellectual property rights of any third party.

For further information on technology, delivery terms and conditions and prices, please contact the Oriental Semiconductor sales representatives (www.orientalsemi.com).

© Oriental Semiconductor Co.,Ltd. All Rights Reserved 