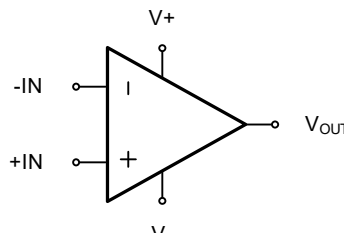

OSU6721 OSU6722 OSU6724

Low-Voltage, Low-noise, Rail-to-Rail I/O CMOS Op Amps

1 Features	2 Application
<ul style="list-style-type: none"> - High gain bandwidth: 10 MHz - Rail-to-rail input and output - Low supply current: 1.4 mA/amplifier at 5 V - Input voltage range: -0.1 V to +5.6 V with $V_S=5.5$ V - Supply range: +2.2 V to +5.5 V - Operation temperature range: -40°C to +125°C 	<ul style="list-style-type: none"> - Sensors - Photodiode amplification - Active filters - Test equipment - Driving A/D converters

3 Description	Circuit Diagram
<p>The OSU672X families of products are low-voltage low-power operational amplifiers that can be designed into a wide range of applications. The OSU672X have a unity-gain bandwidth of 10MHz, a slew rate of 5.5V/μs, and a quiescent current of 1.4 mA/amplifier at 5V.</p> <p>The OSU672X families of products are designed to provide optimal performance in low-voltage systems. They provide rail-to-rail output swing into heavy loads. The input common-mode voltage range includes ground, and the maximum input offset voltage are 1.5mV (over recommended temperature range) for the devices. Their capacitive load capability is also good at low supply voltages. The operating range is from 2.2V to 5.5V.</p>	 <p>The diagram shows a standard operational amplifier symbol. It has two input terminals on the left: the top one is labeled '-IN' and the bottom one is labeled '+IN'. The top input is marked with a minus sign '-' and the bottom with a plus sign '+'. The top supply terminal is labeled 'V+' and the bottom supply terminal is labeled 'V-'. The output terminal on the right is labeled 'V_{OUT}'.</p>

5 Device Summary, Pin and Packages

Table.5-1. Device Summary⁽¹⁾

Serial Name	Part Name	Package	Body Size (Nom)	Marking ⁽²⁾	MSL ⁽³⁾	Package Qty
OSU6721	OSU6721S5	SOT23-5	2.90mm×1.60mm×1.10mm	OSU6721 XXXXX	3	Tape and Reel,3000
	OSU6721C5	SC70-5	2.10mm×1.25mm×1.00mm	OSU6721 XXXX	3	Tape and Reel,3000
	OSU6721BS5	SOT23-5	2.90mm×1.60mm×1.10mm	OSU6721B XXXXX	3	Tape and Reel,3000
	OSU6721M8	MSOP8	3.00mm×3.00mm×1.10mm	OSU6721 XXXXXXXX	3	Tape and Reel,4000
	OSU6721P8	SOP8	6.00mm×3.90mm×1.75mm	OSU6721 XXXXXXXX	3	Tape and Reel,4000
OSU6722	OSU6722M8	MSOP8	3.00mm×3.00mm×1.10mm	OSU6722 XXXXXXXX	3	Tape and Reel,4000
	OSU6722P8	SOP8	6.00mm×3.90mm×1.75mm	OSU6722 XXXXXXXX	3	Tape and Reel,4000
	OSU6722F8	DFN2*2-8L	2.00mm×2.00mm×0.75mm	OSU6722 XXXX	3	Tape and Reel,3000
	OSU6722S8	SOT23-8	2.90mm×1.60mm×1.10mm	OSU6722 XXXXX	3	Tape and Reel,3000
	OSU6722T8	TSSOP8	3.00mm×4.40mm×1.10mm	OSU6722 XXXXXXXX	3	Tape and Reel,5000
OSU6724	OSU6724PD	SOP14	8.65mm×3.90mm×1.75mm	OSU6724 XXXXXXXX	3	Tape and Reel,4000
	OSU6724TD	TSSOP14	5.00mm×4.40mm×1.20mm	OSU6724 XXXXXXXX	3	Tape and Reel,4000

(1) For all available packages, please contact product sales.

(2) There may be additional marking, which relates to the lot trace code information (data code and vendor code), the logo or the environmental category on the device.

(3) MSL, The Moisture Sensitivity Level rating according to the JEDEC industry standard classifications.

(4) "XXXXX" in Marking will be appeared as the batch code.

5 Device Summary, Pin and Packages(Continued)

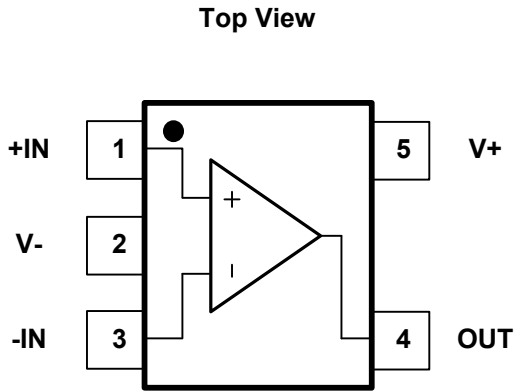

Fig.5-1. OSU6721: C5 (SC70-5) Package
OSU6721: S5 (SOT23-5) Package

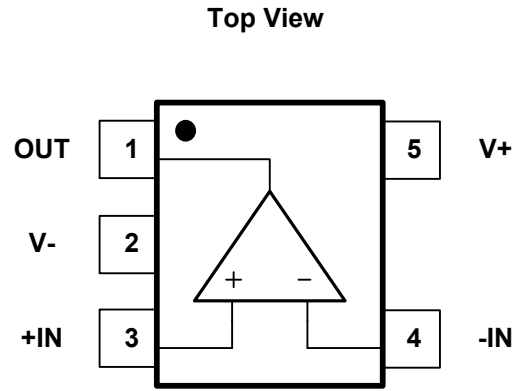

Fig.5-2. OSU6721B: S5 (SOT23-5) Package

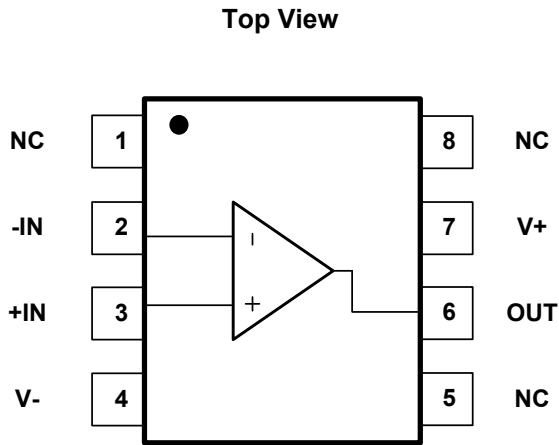

Fig.5-3. OSU6721: M8 (MSOP8) Package
OSU6721: P8 (SOP8) Package

Table.5-2. Pin Definition

Name	Pin			I/O	Description
	C5 S5	BS5	M8 P8		
-IN	3	4	2	I	Inverting input
+IN	1	3	3	I	Noninverting input
NC	-	-	1,5,8	-	No internal connection (can be left floating)
OUT	4	1	6	O	Output
V-	2	2	4	-	Negative (lowest) supply or ground (for single-supply operation)
V+	5	5	7	-	Positive (highest) supply

* It is suggested to leave the unconnected pins floating.

5 Device Summary, Pin and Packages(Continued)

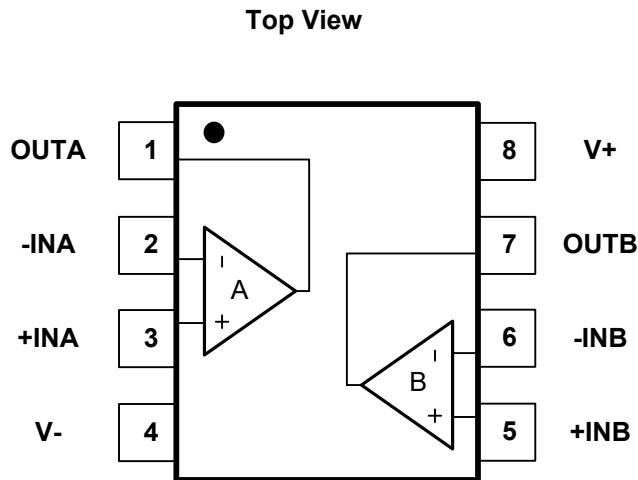

Fig.5-4. OSU6722: M8(MSOP8) Package
OSU6722: P8(SOP8) Package

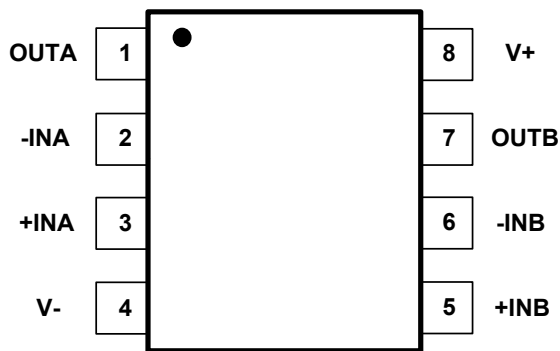

Fig. 5-6. OSU6722: S8 (SOP23-8) Package

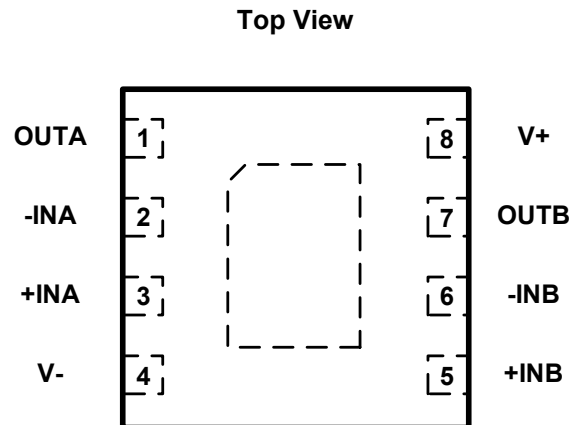

Fig. 5-5. OSU6722: F8(DFN2*2-8) Package

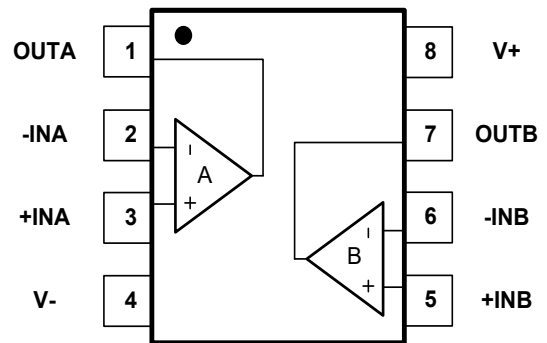

Fig. 5-7. OSU6722: T8 (TSSOP8) Package

Table.5-3. Pin Definition

Pin		I/O	Description
Name	M8 P8 F8 S8 T8		
-INA	2	I	Inverting input, channel A
+INA	3	I	Noninverting input, channel A
-INB	6	I	Inverting input, channel B
+INB	5	I	Noninverting input, channel B
OUTA	1	O	Output, channel A
OUTB	7	O	Output, channel B
V-	4	-	Negative (lowest) supply or ground (for single-supply operation)
V+	8	-	Positive (highest) supply

* It is suggested to leave the unconnected pins floating.

5 Device Summary, Pin and Packages(Continued)

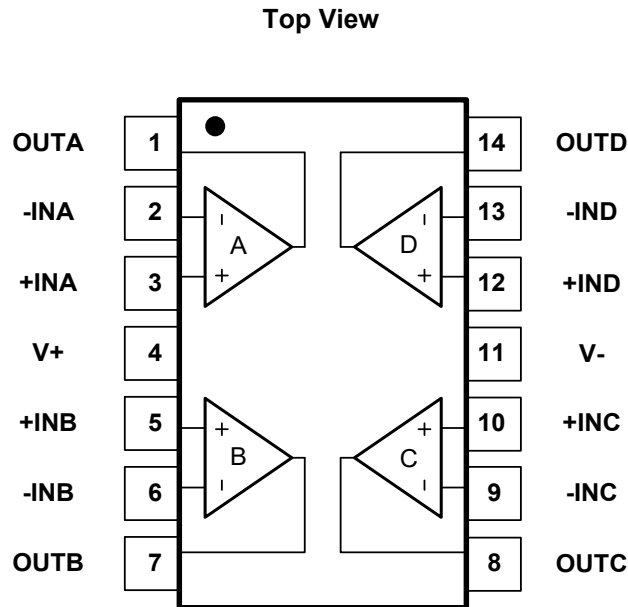

Fig.5-8. OSU6724: TD (TSSOP14) Package

OSU6724: PD (SOP14) Package

Table.5-4. Pin Definition

Pin		I/O	Description
Name	TD PD		
-INA	2	I	Inverting input, channel A
+INA	3	I	Noninverting input, channel A
-INB	6	I	Inverting input, channel B
+INB	5	I	Noninverting input, channel B
-INC	9	I	Inverting input, channel C
+INC	10	I	Noninverting input, channel C
-IND	13	I	Inverting input, channel D
+IND	12	I	Noninverting input, channel D
OUTA	1	O	Output, channel A
OUTB	7	O	Output, channel B
OUTC	8	O	Output, channel C
OUTD	14	O	Output, channel D
V-	11	-	Negative (lowest) supply or ground (for single-supply operation)
V+	4	-	Positive (highest) supply

* It is suggested to leave the unconnected pins floating.

6 Voltage, Temperature, ESD and Thermal Ratings

6.1 Absolute Maximum Ratings⁽¹⁾

Parameters	Min.	Max.	Unit
Supply Voltage $V_s=(V^+)-(V^-)$		6.5	V
Select Input Voltage ⁽²⁾	$(V^-)-0.5$	$(V^+)+0.5$	V
Maximum Junction Temperature	-55	150	°C
Storage Temperature Range	-55	150	°C

(1) Stresses above these ratings may cause permanent damage. Exposure to absolute maximum conditions for extended periods may degrade device reliability. These are stress ratings only, and functional operation of the device at these or any other conditions beyond those specified is not implied.

(2) Input terminals are diode-clamped to the power-supply rails. Input signals that can swing more than 0.3V beyond the supply rails should be current-limited to 10mA or less.

6.2 ESD Ratings

ESD			Value	Unit
V(ESD)	Electrostatic discharge	Human-Body Model (HBM) ⁽¹⁾	3.5 K	V
		Charged-Device Model (CDM) ⁽²⁾	2 K	V

(1) JEDEC document JEP155 states that 500-V HBM allows safe manufacturing with a standard ESD control process.

(2) JEDEC document JEP157 states that 250-V CDM allows safe manufacturing with a standard ESD control process.

6.3 Recommended Operating Conditions

Over operating free-air temperature range (unless otherwise noted)

Symbol	Parameters	Min.	Max.	Unit
Supply voltage, $V_{CC}=(V^+)-(V^+)$	Single-supply	2.2	5.5	V
	Dual-supply	±1.1	±2.75	
TA	Operating temperature	-40	125	°C

6.4 Thermal Information

Package Type	θ_{JA}	θ_{JC}	Unit
SC70-5	400	150	°C/W
SOT23-5	250	81	°C/W
MSOP8	210	45	°C/W
SOP8	158	43	°C/W
SOT23-8	184	61	°C/W
TSSOP8	191	50	°C/W
DFN2*2-8L	100	60	°C/W
TSSOP14	180	35	°C/W
SOP14	120	36	°C/W

7 Electrical Specifications

$V_{CC}=5.0V$, $V_{CM}=V_{CC}/2$, and $R_L=10K\Omega$, FULL= $-40^{\circ}C$ to $+125^{\circ}C$, Typical values are at $T_A=+25^{\circ}C$. (unless otherwise noted)

Parameters	Symbol	Conditions	Vcc	TA	Min.	Typ.	Max.	Unit
Offset Voltage								
Input Offset Voltage	Vos		5V	+25°C	-1.5	±0.5	1.5	mV
Input Offset Voltage Average Drift	Vos TC	-40°C to +125°C	5V			±1		µV/°C
Power-supply Rejection Ratio	PSRR	$V_{CC}=2.2V$ to $5V$, $V_{CM}=(V-)+0.5V$		+25°C	70	95		dB
				FULL	65			
Input Voltage Range								
Common-mode Voltage Range	Vcm		5.5V	+25°C	-0.1		5.6	V
Common-mode Rejection Ratio	CMRR	$V_{CM}=0V$ to $4.1V$	5.5V	+25°C	57	88		dB
				FULL	55			
		$V_{CM}=0V$ to $5.6V$		+25°C	60	82		
				FULL	57			
Input Impedance								
Differential			5V	+25°C		$10^{12} 1.3$		ΩpF
Common-mode			5V	+25°C		$10^{12} 8.6$		ΩpF
Input Bias Current								
Input Bias Current	IB		5V	+25°C		0.3		pA
Input Offset Current	IOS		5V	+25°C		0.3		pA
Noise								
Input Voltage Noise Density	en	f=1kHz	5V	+25°C		8		nV/√Hz
		f=10kHz	5V	+25°C		5.5		nV/√Hz
Open-loop Gain								
Open-loop Voltage Gain	AOL	$R_L=2K\Omega$, $V_O=0.15V$ to $4.85V$	5V	+25°C	100	110		dB
				FULL	90			
		$R_L=10K\Omega$, $V_O=0.05V$ to $4.95V$		+25°C	105	110		
				FULL	95			
Frequency Response								
Gain Bandwidth Product	GBW		5V	+25°C		10		MHz
Phase Margin	PM		5V	+25°C		60		°
Slew Rate	SR		5V	+25°C		5.5		V/µs
Overload Recovery Time	t _{OR}	$V_{IN} \cdot \text{Gain} \geq V_S$	5V	+25°C		0.7		µs

7 Electrical Specifications (Continued)

V_{cc}=5.0V, V_{cm}=V_{cc}/2, and R_L=10KΩ, FULL= -40°C to +125°C, Typical values are at TA=+25°C. (unless otherwise noted)

Parameters	Symbol	Conditions	V _{cc}	TA	Min.	Typ.	Max.	Unit
Output								
Output Swing from Rail		RL=2KΩ	5V	+25°C		15		mV
				FULL		20		
		RL=10KΩ		+25°C		5		
				FULL		7		
Output Current	I _{out}		5V	+25°C		100		mA
				FULL		90		
Power Supply								
Quiescent Current/Amplifier	I _Q		5V	+25°C		1.4	2.5	mA

8 Typical Characteristics

$V_{cc}=5.0V$, $V_{cm}=V_{cc}/2$, and $R_L=10K\Omega$, FULL= $-40^{\circ}C$ to $+125^{\circ}C$, Typical values are at $T_A=+25^{\circ}C$. (unless otherwise noted)

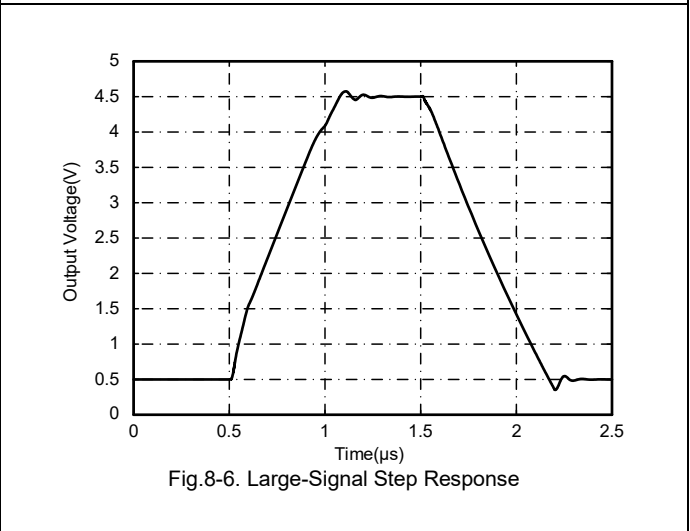
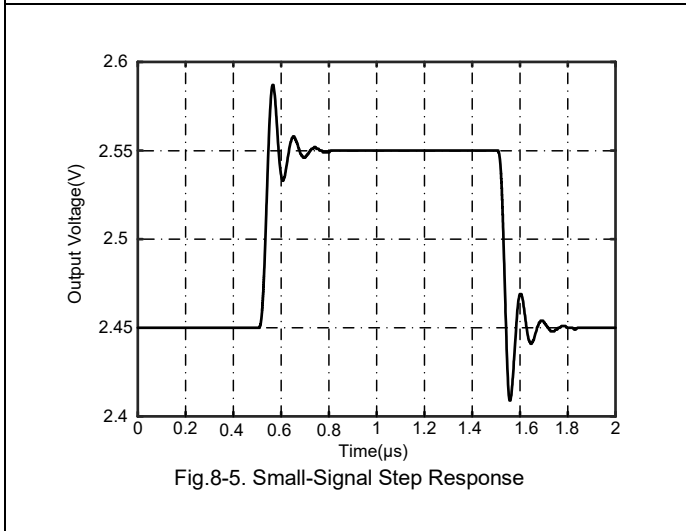
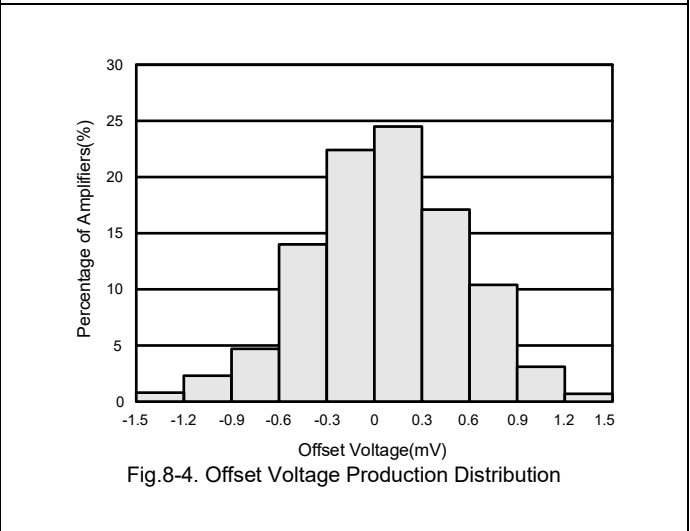
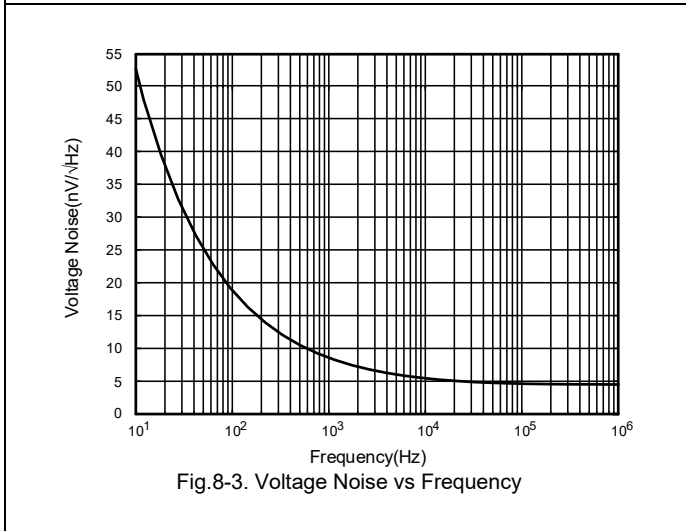
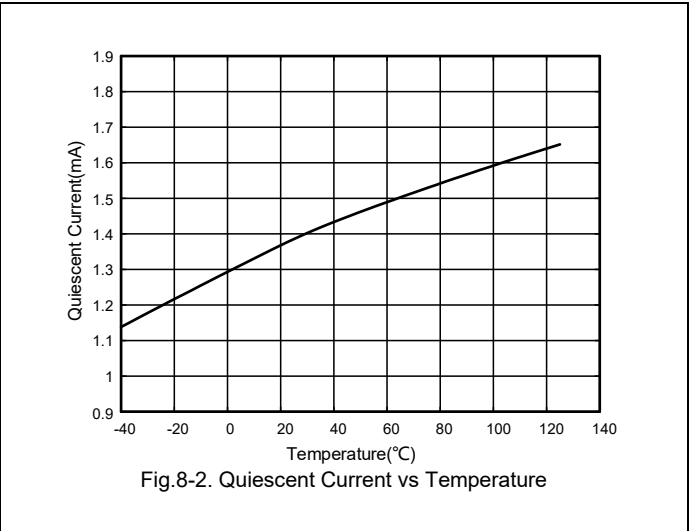
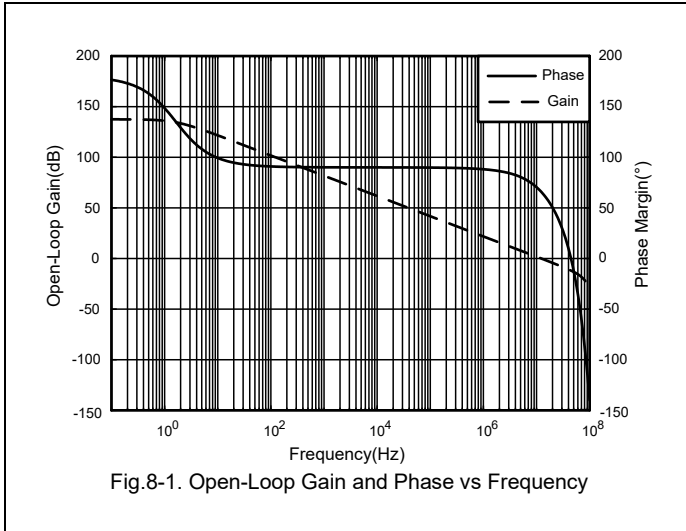

9 Detailed Description

The OSU672X families of products are rail-to-rail operational amplifiers that can be run from a single-supply voltage 2.2V to 5.5V ($\pm 1.1V$ to $\pm 2.75V$). Supply voltages higher than 6.5V (absolute maximum) can permanently damage the amplifier. Rail-to-rail input and output swing significantly increases dynamic range, especially in low-supply applications.

Attention to good layout practices is always recommended. Keep traces short. When possible, use a PCB ground plane with surface-mount components placed as close to the device pins as possible. Place a 0.1 μ F capacitor closely across the supply pins. These guidelines should be applied throughout the analog circuit to improve performance and provide benefits such as reducing the EMI susceptibility.

10 Application Note

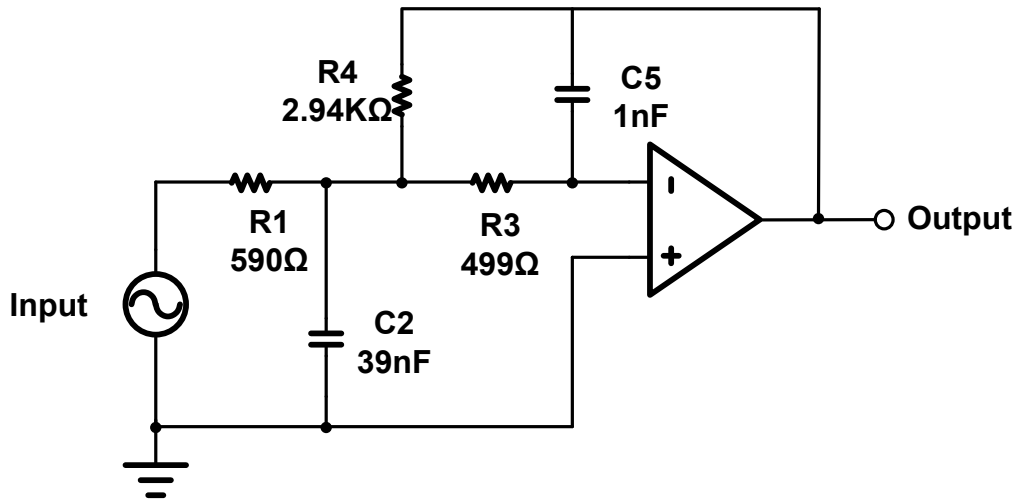

Fig.10-1. 25-kHz Low-pass Filter

Low-pass filters are commonly employed in signal processing applications to reduce noise and prevent aliasing. The OSU672X devices are ideally suited to construct high-speed, high-precision active filters. Fig.10-1 shows a second-order, low-pass filter commonly encountered in signal processing applications.

Use the following parameters for this design example:

- Gain = 5V/V (inverting gain)
- Low-pass cutoff frequency = 25kHz
- Second-order Chebyshev filter response with 3-dB gain peaking in the passband

11 Package Outline Dimension

SOT23-5

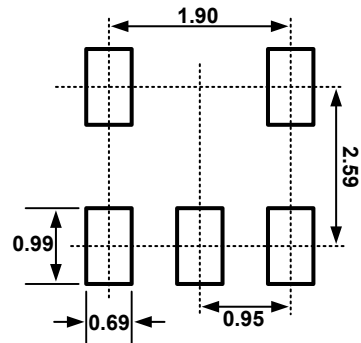
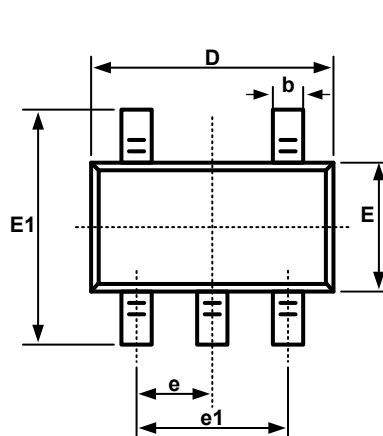

Recommended Land Pattern (Unit: mm)

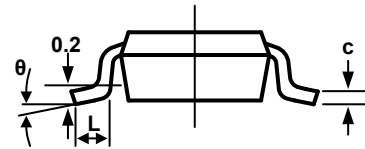
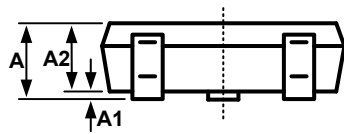

Symbol	Dimensions in Millimeters		Dimensions in Inches	
	Min.	Max.	Min.	Max.
A	1.050	1.250	0.041	0.049
A1	0.000	0.100	0.000	0.004
A2	1.050	1.150	0.041	0.045
b	0.300	0.500	0.012	0.020
c	0.100	0.200	0.004	0.008
D	2.820	3.020	0.111	0.119
E	1.500	1.700	0.059	0.067
E1	2.650	2.950	0.104	0.116
e	0.950(BSC)		0.037(BSC)	
e1	1.800	2.000	0.071	0.079
L	0.300	0.600	0.012	0.024
L1	0.600REF		0.024REF	
θ	0°	8°	0°	8°

11 Package Outline Dimension(Continued)

SC70-5

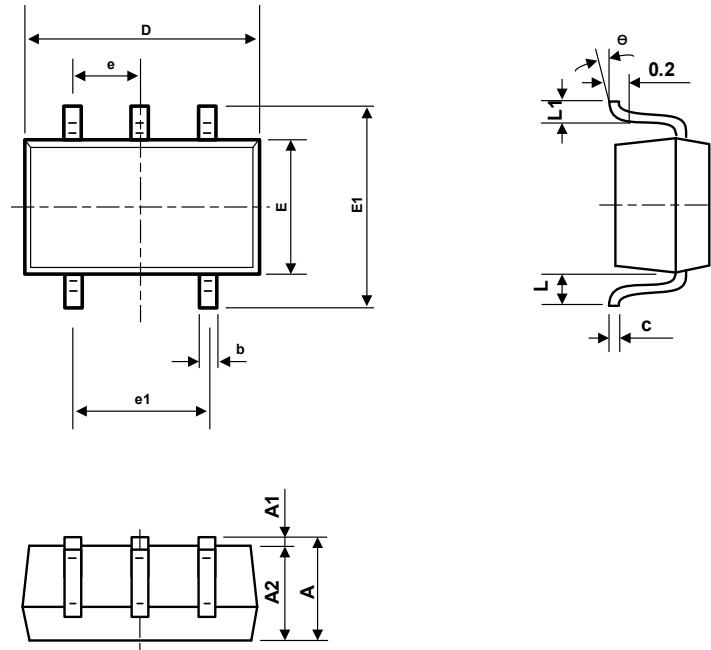

Symbol	Dimensions in Millimeters		Dimensions in Inches	
	Min.	Max.	Min.	Max.
A	0.900	1.100	0.035	0.043
A1	0.000	0.100	0.000	0.004
A2	0.900	1.000	0.035	0.039
b	0.150	0.350	0.006	0.014
c	0.110	0.175	0.004	0.007
D	2.000	2.200	0.079	0.087
E	1.150	1.350	0.045	0.053
E1	2.150	2.450	0.085	0.096
e	0.650TYP		0.026TYP	
e1	1.200	1.400	0.047	0.055
L	0.525REF		0.021REF	
L1	0.260	0.460	0.010	0.018
θ	0°	8°	0°	8°

11 Package Outline Dimension(Continued)

SOT23-8

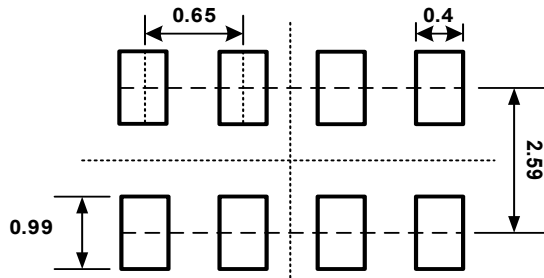
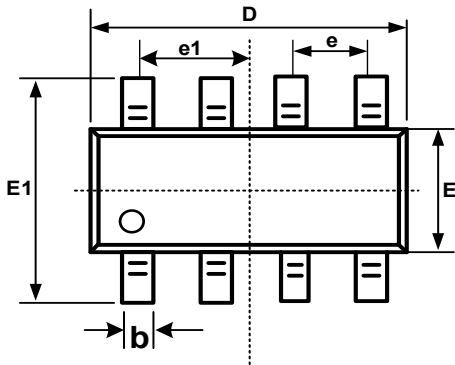

Recommended Land Pattern (Unit: mm)

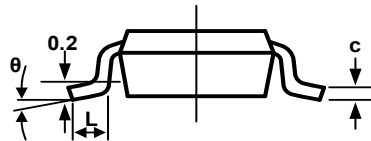
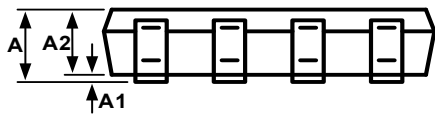

Symbol	Dimensions In Millimeters		Dimensions In Inches	
	Min	Max	Min	Max
A	1.050	1.250	0.041	0.049
A1	0.000	0.100	0.000	0.004
A2	1.050	1.150	0.041	0.045
b	0.300	0.500	0.012	0.020
c	0.100	0.200	0.004	0.008
D	2.820	3.020	0.111	0.119
E	1.500	1.700	0.059	0.067
E1	2.650	2.950	0.104	0.116
e	0.650BSC		0.026BSC	
e1	0.975BSC		0.038BSC	
L	0.300	0.600	0.012	0.024
θ	0°	8°	0°	8°

11 Package Outline Dimension(Continued)

TSSOP8

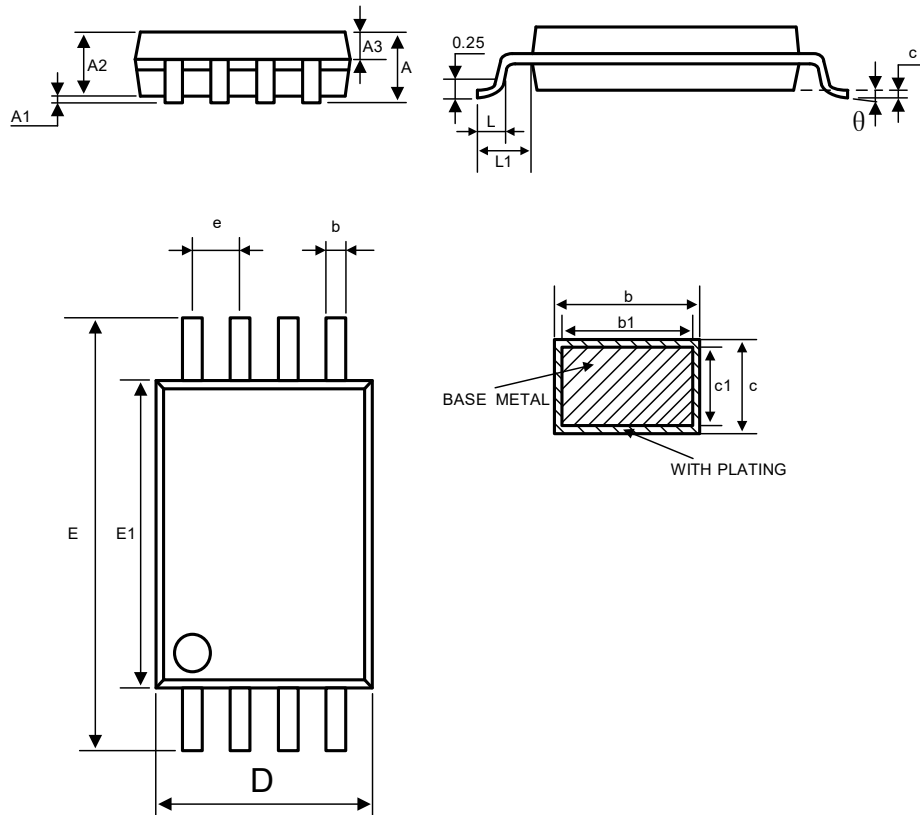

Symbol	Dimensions in Millimeters			Dimensions in Inches		
	Min.	Nom.	Max.	Min.	Nom.	Max.
A	—	—	1.20	—	—	0.047
A1	0.05	—	0.15	0.002	—	0.006
A2	0.90	1.00	1.05	0.035	0.039	0.041
A3	0.39	0.44	0.49	0.015	0.017	0.019
b	0.20	—	0.28	0.008	—	0.011
b1	0.19	0.22	0.25	0.007	0.009	0.010
c	0.13	—	0.17	0.005	—	0.007
c1	0.12	0.13	0.14	0.005	0.005	0.006
D	2.90	3.00	3.10	0.114	0.118	0.122
E1	4.30	4.40	4.50	0.169	0.173	0.177
E	6.20	6.40	6.60	0.244	0.251	0.260
e	0.65BSC			0.026BSC		
L	0.45	—	0.75	0.018	—	0.030
L1	1.00REF			0.039REF		
θ	0	—	8°	0	—	8°

11 Package Outline Dimension(Continued)

DFN2*2-8L

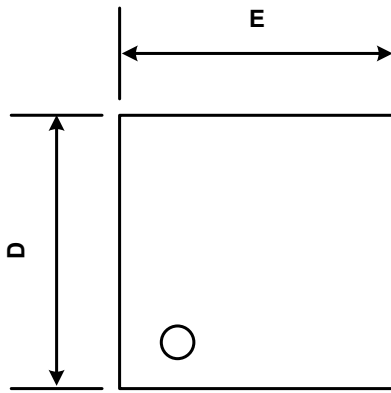

TOP VIEW

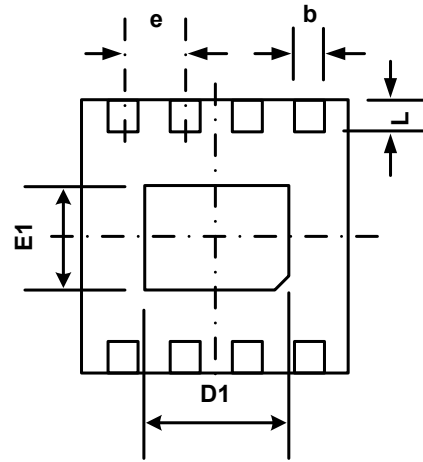

BOTTOM VIEW

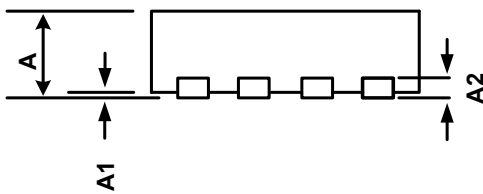

SIDE VIEW

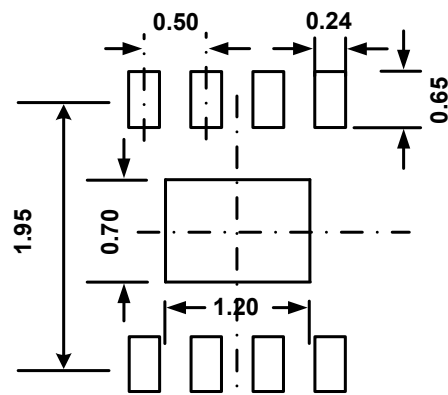

RECOMMENDED LAND PATTERN(unit:mm)

Symbol	Dimensions in Millimeters		Dimensions in Inches	
	Min.	Max.	Min.	Max.
A	0.700	0.800	0.028	0.031
A1	0.000	0.050	0.000	0.002
A2	0.203(TYP)		0.035(TYP)	
b	0.180	0.300	0.007	0.012
D	1.900	2.100	0.075	0.083
D1	1.100	1.300	0.043	0.051
E	1.900	2.100	0.075	0.083
E1	0.600	0.800	0.024	0.031
e	0.500(TYP)		0.020TYP	
L	0.250	0.450	0.010	0.018

11 Package Outline Dimension(Continued)

MSOP8

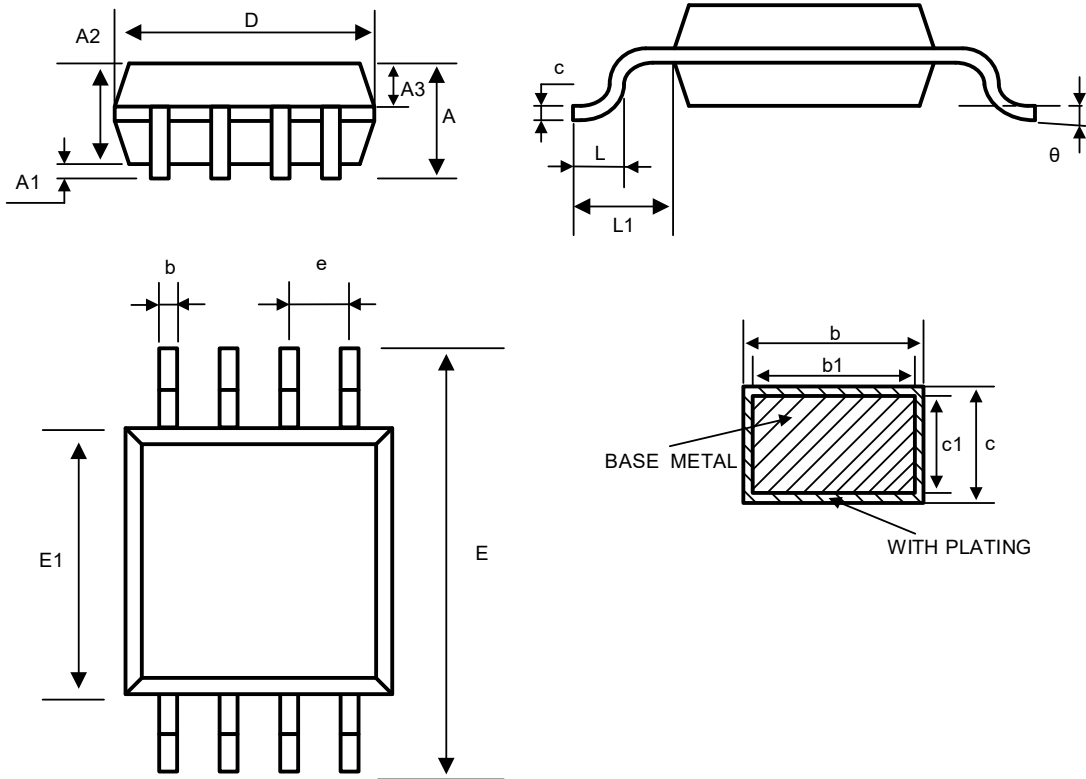

Symbol	Dimensions in Millimeters			Dimensions in Inches		
	Min.	Nom.	Max.	Min.	Nom.	Max.
A	—	—	1.10	—	—	0.043
A1	0.05	—	0.15	0.002	—	0.006
A2	0.75	0.85	0.95	0.030	0.033	0.037
A3	0.30	0.35	0.40	0.012	0.014	0.016
b	0.28	—	0.36	0.011	—	0.014
b1	0.27	0.30	0.33	0.011	0.012	0.013
c	0.15	—	0.19	0.006	—	0.007
c1	0.14	0.15	0.16	0.006	0.006	0.006
D	2.90	3.00	3.10	0.114	0.118	0.122
E	4.70	4.90	5.10	0.185	0.193	0.201
E1	2.90	3.00	3.10	0.114	0.118	0.122
e	0.65BSC			0.026BSC		
L	0.40	—	0.70	0.016	—	0.028
L1	0.95REF			0.037REF		
θ	0	—	8°	0	—	8°

11 Package Outline Dimension(Continued)

SOP8

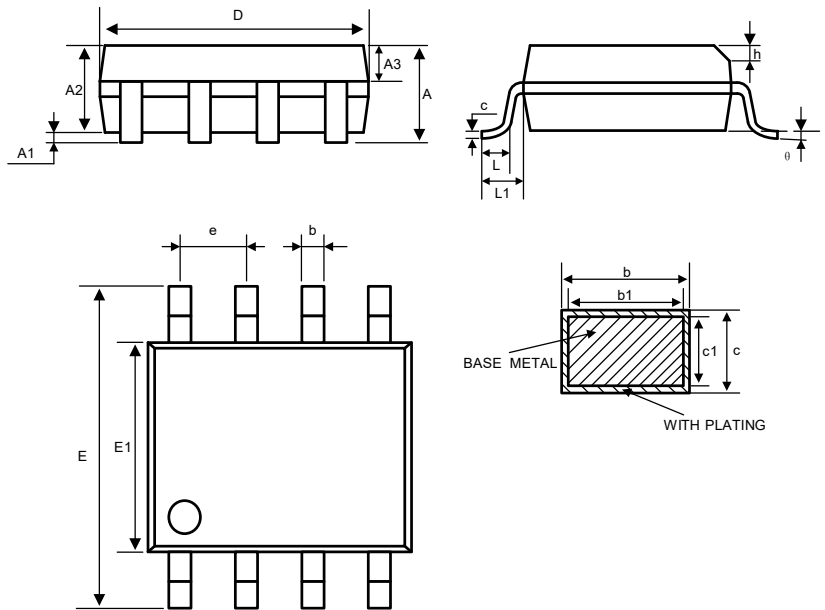

Symbol	Dimensions in Millimeters			Dimensions in Inches		
	Min.	Nom.	Max.	Min.	Nom.	Max.
A	—	—	1.75	—	—	0.069
A1	0.10	—	0.225	0.004	—	0.009
A2	1.30	1.40	1.50	0.051	0.055	0.059
A3	0.60	0.65	0.70	0.024	0.026	0.028
b	0.39	—	0.47	0.015	—	0.019
b1	0.38	0.41	0.44	0.015	0.016	0.017
c	0.20	—	0.21	0.008	—	0.008
c1	4.80	4.90	5.00	0.189	0.193	0.197
D	5.80	6.00	6.20	0.228	0.236	0.244
E	5.80	6.00	6.20	0.228	0.236	0.244
E1	3.80	3.90	4.00	0.150	0.154	0.157
e	1.27BSC			0.05BSC		
h	0.25	—	0.50	0.010	—	0.020
L	0.50	—	0.80	0.020	—	0.031
L1	1.05REF			0.041REF		
θ	0	—	8°	0	—	8°

11 Package Outline Dimension(Continued)

TSSOP14

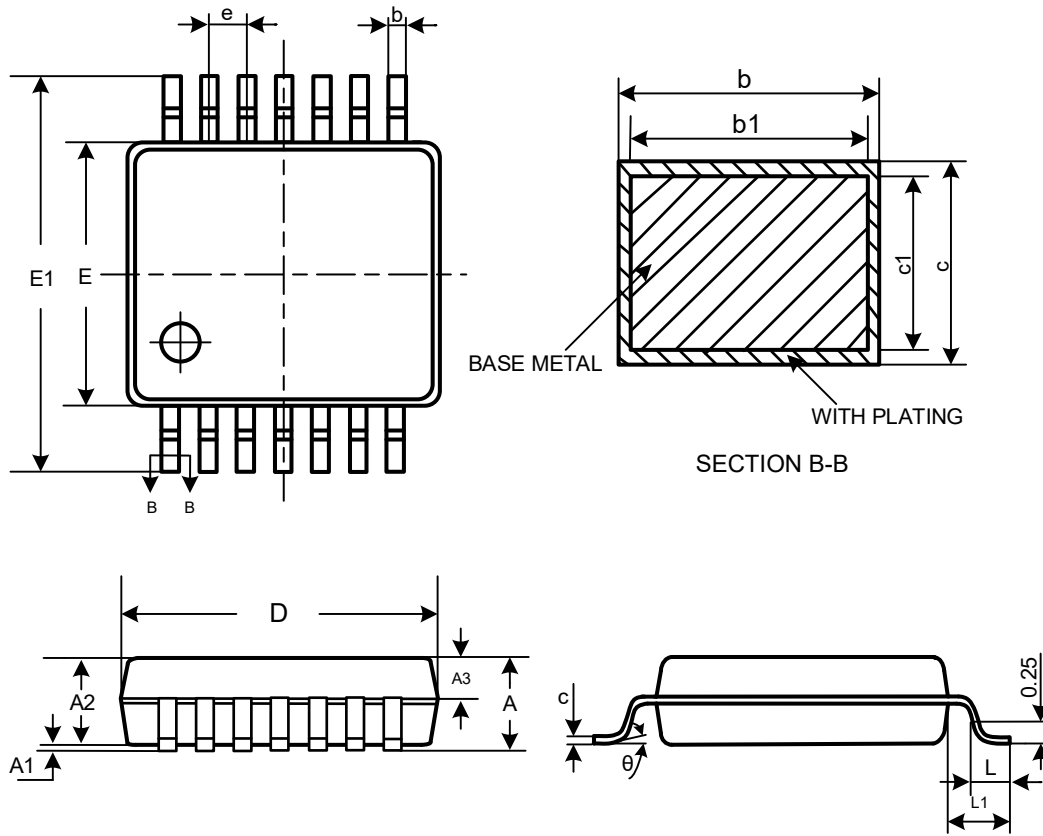

SYMBOL	Dimensions in Millimeters			Dimensions in Inches		
	Min.	Nom.	Max.	Min.	Nom.	Max.
A	—	—	1.20	—	—	0.047
A1	0.05	—	0.15	0.002	—	0.006
A2	0.90	1.00	1.05	0.035	0.039	0.041
A3	0.39	0.44	0.49	0.015	0.017	0.019
b	0.20	—	0.28	0.008	—	0.011
b1	0.19	0.22	0.25	0.007	0.009	0.010
c	0.13	—	0.17	0.005	—	0.007
c1	0.12	0.13	0.14	0.005	0.005	0.006
D	4.90	5.00	5.10	0.193	0.197	0.201
E	4.30	4.40	4.50	0.169	0.173	0.177
E1	6.20	6.40	6.60	0.244	0.252	0.260
e	0.65BSC			0.026BSC		
L	0.45	0.60	0.75	0.018	0.024	0.030
L1	1.00BCS			0.039BSC		
θ	0	—	8°	0	—	8°

11 Package Outline Dimension(Continued)

SOP14

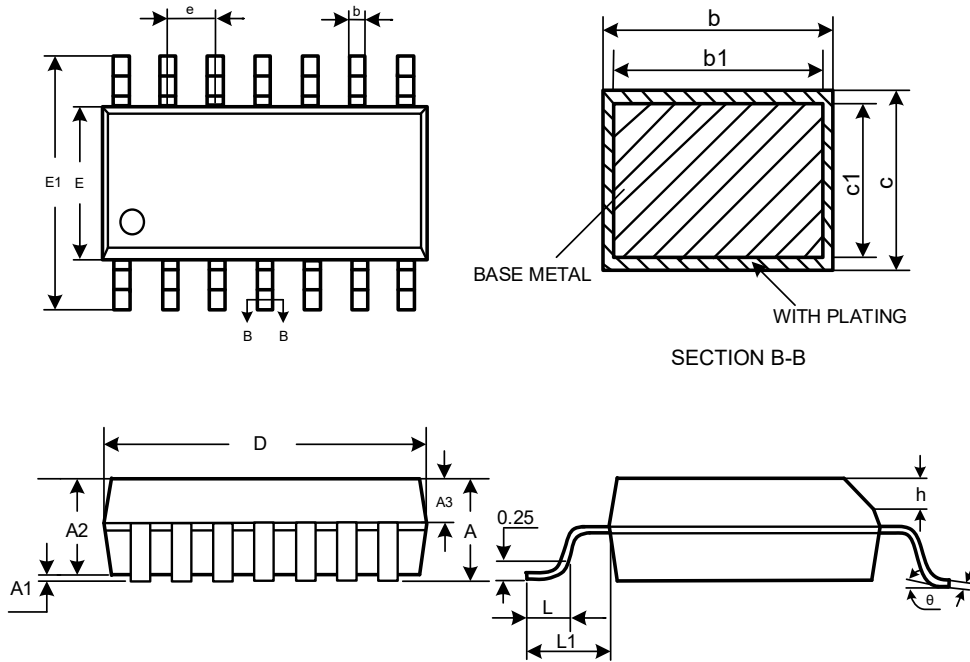

SYMBOL	Dimensions in Millimeters			Dimensions in Inches		
	Min.	Nom.	Max.	Min.	Nom.	Max.
A	—	—	1.75	—	—	0.069
A1	0.10	—	0.225	0.004	—	0.009
A2	1.30	1.40	1.50	0.051	0.055	0.059
A3	0.60	0.65	0.70	0.024	0.026	0.028
b	0.39	—	0.47	0.015	—	0.019
b1	0.38	0.41	0.44	0.015	0.016	0.017
c	0.20	—	0.24	0.20	—	0.24
c1	0.19	0.20	0.21	0.007	0.008	0.008
D	8.55	8.65	8.75	0.337	0.341	0.344
E1	5.80	6.00	6.20	0.228	0.236	0.244
E	3.80	3.90	4.00	0.150	0.154	0.157
e	1.27BSC			0.05BSC		
h	0.25	—	0.50	0.010	—	0.020
L	0.50	—	0.80	0.020	—	0.031
L1	1.05REF			0.041REF		
θ	0	—	8°	0	—	8°

12 Tape and Reel Information

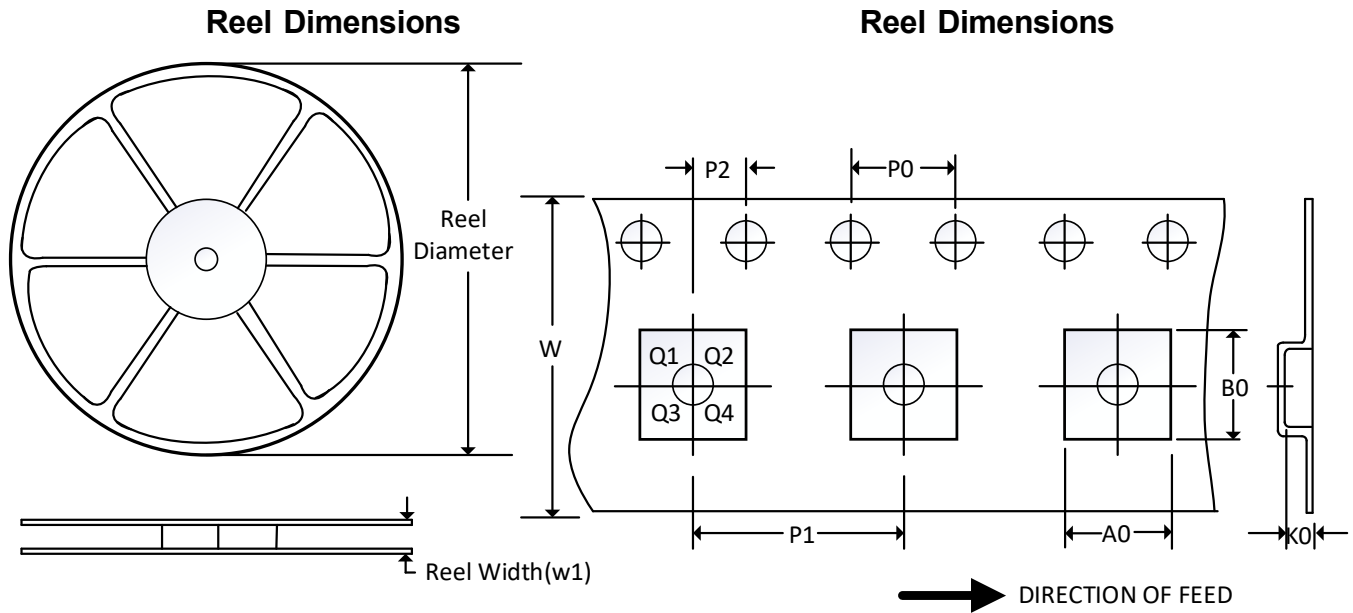

NOTE: The picture is only for reference. Please make the object as the standard.

Key Parameter List of Tape and Reel

Package Type	Reel Diameter	Reel Width (mm)	A0 (mm)	B0 (mm)	K0 (mm)	P0 (mm)	P1 (mm)	P2 (mm)	W (mm)	Pin1 Quadrant
SC70-5	7"	9.5	2.25	2.55	1.20	4.0	4.0	2.0	8.0	Q3
SOT23-5	7"	9.5	3.20	3.20	1.40	4.0	4.0	2.0	8.0	Q3
DFN2*2-8L	7"	9.5	2.30	2.30	1.10	4.0	4.0	2.0	8.0	Q2
SOT23-8	7"	9.5	3.17	2.23	1.37	4.0	4.0	2.0	8.0	Q3
TSSOP8	13"	12.4	6.90	3.45	1.65	4.0	8.0	2.0	12.0	Q1
MSOP8	13"	12.4	5.20	3.30	1.50	4.0	8.0	2.0	12.0	Q1
SOP8	13"	12.4	6.40	5.40	2.10	4.0	8.0	2.0	12.0	Q1
TSSOP14	13"	12.4	6.95	5.60	1.20	4.0	8.0	2.0	12.0	Q1
SOP14	13"	16.4	6.60	9.30	2.10	4.0	8.0	2.0	16.0	Q1

NOTE:

1. All dimensions are nominal.
2. Plastic or metal protrusions of 0.15mm maximum per side are not included.

Legal Disclaimer

The information given in this document shall in no event be regarded as a guarantee of conditions or characteristics. With respect to any examples or hints given herein, any typical values stated herein and/or any information regarding the application of the device, Oriental Semiconductor hereby disclaims any and all warranties and liabilities of any kind, including without limitation, warranties of non-infringement of intellectual property rights of any third party.

For further information on technology, delivery terms and conditions and prices, please contact the Oriental Semiconductor sales representatives (www.orientalsemi.com).

© Oriental Semiconductor Co.,Ltd. All Rights Reserved 