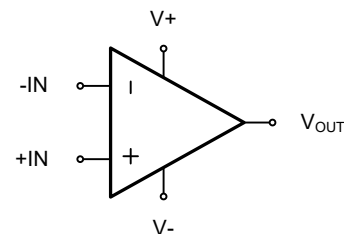

OSU6321 OSU6358 OSU6324 High Voltage General Purpose Operational Amplifier

1 Features	2 Application
<ul style="list-style-type: none"> - Ultra-low input offset voltage: $\pm 3\text{mV}$ - Power supply voltage: $+3\text{V}$ to $+36\text{V}$ - Support single and dual power supply - Low quiescent current: $100\mu\text{A}/\text{channel}$ - Low wideband noise: $35\text{nV}/\sqrt{\text{Hz}}$ - Rail to Rail output - Unity-bandwidth gain: 1.5 MHz - Operating temperature range: -40°C to $+125^{\circ}\text{C}$ 	<ul style="list-style-type: none"> - Motor driver - Sensor module - Household appliances - Power supply module - Inverter - UPS - Air conditioning inside and outside - Automotive electronics

3 Description	Circuit Diagram
<p>OSU6321, OSU6358, OSU6324 high-voltage general purpose operational amplifiers from OSU6IC is manufactured using advanced processes with full process standardization and control. The series includes single op-amp(OSU6321), dual op-amp(OSU6358), and quad op-amp(OSU6324), which feature unique circuit design techniques and classic rail-to-rail input/output swing. They exhibit high consistency and symmetry within the entire working voltage and temperature range, making them particularly suitable for applications that have high cost requirements and limited space, where the amplifiers can be well-coordinated and balanced with the overall circuit design.</p> <p>OSU6321, OSU6358, OSU6324 chips includes built in over load protection circuits that allow the amplifier store cover from overloads and resume operation in a short amount of time, greatly enhancing the circuit's reliability.</p>	 <p>The diagram shows a standard operational amplifier symbol. It is a triangle with a vertical line on the left side. The top vertex is labeled 'V+' and the bottom vertex is labeled 'V-'. On the left side, there are two input terminals: the top one is labeled '-IN' and the bottom one is labeled '+IN'. On the right side, there is one output terminal labeled 'V_{OUT}'.</p>

4 Device Summary, Pin and Packages

Table 4-1. Device Summary⁽¹⁾

Serial Name	Part Name	Package	Body Size (Nom)	Marking ⁽²⁾	MSL ⁽³⁾	Package Qty
OSU6321	OSU6321S5	SOT23-5	2.90mm×1.60mm×1.10mm	OSU6321 XXXXX	3	Tape and Reel,3000
	OSU6321BS5	SOT23-5	2.90mm×1.60mm×1.10mm	OSU6321B XXXXX	3	Tape and Reel,3000
OSU6358	OSU6358F8	DFN2*2-8L	2.00mm×2.00mm×1.10mm	358 XXXX	3	Tape and Reel,3000
	OSU6358P8	SOP8	4.90mm×3.90mm×1.75mm	OSU6358 XXXXXXXX	3	Tape and Reel,4000
	OSU6358T8	TSSOP8	3.00mm×4.40mm×1.10mm	OSU6358 XXXXXXXX	3	Tape and Reel,4000
	OSU6358M8	MSOP8	3.00mm×3.00mm×1.10mm	OSU6358 XXXXXXXX	3	Tape and Reel,4000
OSU6324	OSU6324PD	SOP14	8.65mm×3.90mm×1.75mm	OSU6324 XXXXXXXX	3	Tape and Reel,4000
	OSU6324TD	TSSOP14	5.00mm×4.40mm×1.20mm	OSU6324 XXXXXXXX	3	Tape and Reel,4000

(1) For all available packages, please contact product sales.

(2) There may be additional marking, which relates to the lot trace code information (data code and vendor code), the logo or the environmental category on the device.

(3) MSL, The Moisture Sensitivity Level rating according to the JEDEC industry standard classifications.

(4) "XXXXXX" in Marking will be appeared as the batch code.

4 Device Summary, Pin and Packages(Continued)

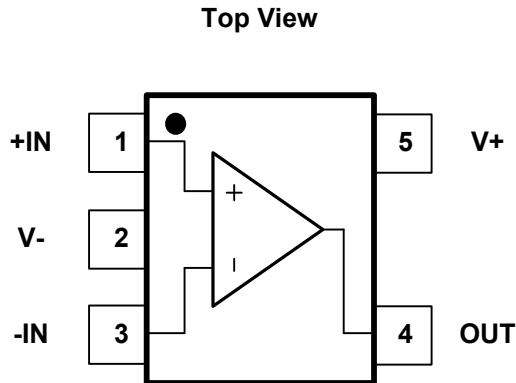

Fig.4-1. OSU6321: S5(SOT23-5) Package

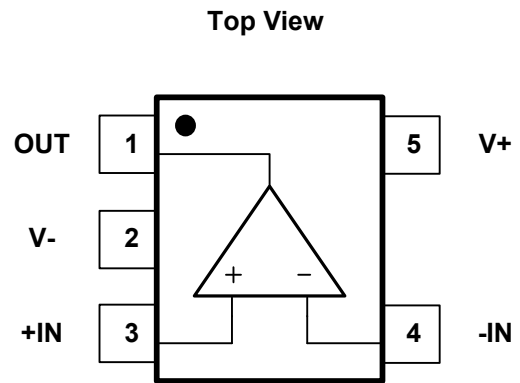

Fig.4-2. OSU6321B: S5(SOT23-5) Package

Table 4-2 Pin Definition

Name	Pin		I/O	Description
	S5	BS5		
-IN	3	4	I	Negative (inverting) input
+IN	1	3	I	Positive(noninverting) input
NC	-	-	-	No internal connection (can be left floating)
OUT	4	1	O	Output
V-	2	2	-	Negative (lowest) power supply
V+	5	5	-	Positive (highest) power supply

* It is suggested to leave the unconnected pins floating.

4 Device Summary, Pin and Packages(Continued)

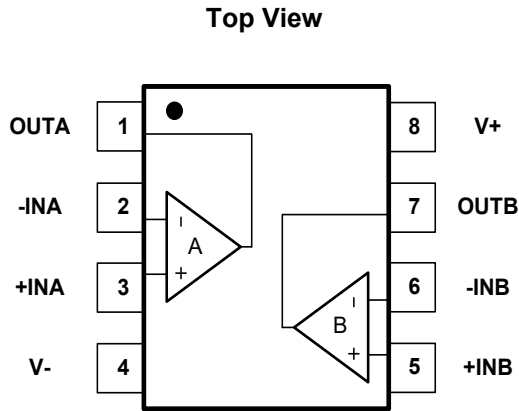

Fig.4-3. OSU6358: P8(SOP8) Package

OSU6358: M8(MSOP8) Package

OSU6358: T8(TSSOP8) Package

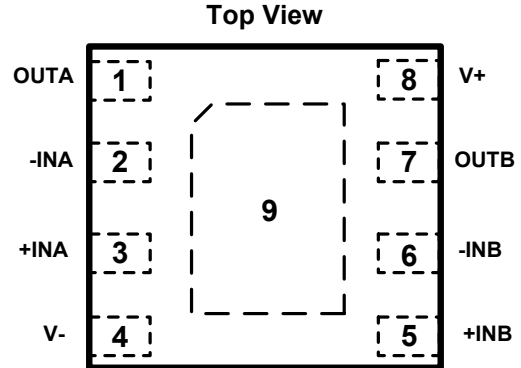

Fig.4-4. OSU6358: F8(DFN2*2-8L) Package

Table 4-3 Pin Definition

Name	Pin				I/O	Description
	P8	M8	T8	F8		
-INA		2			I	Inverting input, channel A
+INA		3			I	Noninverting input, channel A
-INB				6	I	Inverting input, channel B
+INB				5	I	Noninverting input, channel B
OUTA	1				O	Output, channel A
OUTB				7	O	Output, channel B
V-		4			-	Negative (lowest) power supply
V+				8	-	Positive (highest) power supply

* It is suggested to leave the unconnected pins floating

4 Device Summary, Pin and Packages(Continued)

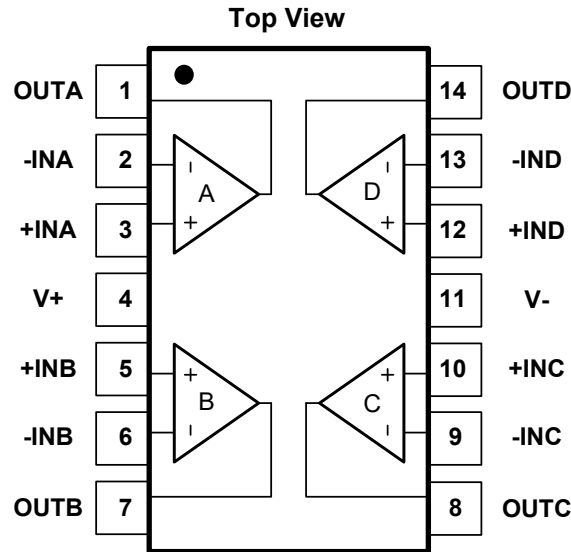

**Fig.4-5. OSU6324: TD(TSSOP14) Package
OSU6324: PD(SOP14) Package**

Table 4-4 Pin Definition

Name	Pin		I/O	Description
	PD	TD		
-INA	2		I	Inverting input, channel A
+INA	3		I	Noninverting input, channel A
-INB	6		I	Inverting input, channel B
+INB	5		I	Noninverting input, channel B
-INC	9		I	Inverting input, channel C
+INC	10		I	Noninverting input, channel C
-IND	13		I	Inverting input, channel D
+IND	12		I	Noninverting input, channel D
OUTA	1		O	Output, channel A
OUTB	7		O	Output, channel B
OUTC	8		O	Output, channel C
OUTD	14		O	Output, channel D
V-	11		-	Negative (lowest) power supply
V+	4		-	Positive (highest) power supply

* It is suggested to leave the unconnected pins floating.

5 Voltage, Temperature, ESD and Thermal Ratings

5.1 Absolute Maximum Ratings

Parameters ⁽¹⁾	Min.	Max.	Unit
Supply Voltage, $V_S=(V+) - (V-)$	0	40	V
Select Input Voltage ⁽²⁾	(V-)-0.3	(V+)+0.3	V
Maximum Junction Temperature	-45	160	°C
Storage Temperature Range	-65	150	°C

(1) Stresses above these ratings may cause permanent damage. Exposure to absolute maximum conditions for extended periods may degrade device reliability. These are stress ratings only, and functional operation of the device at these or any other conditions beyond those specified is not implied.

(2) Input terminals are diode-clamped to the power-supply rails. Input signals that can swing more than 0.3V beyond the supply rails should be current-limited to 10mA or less.

5.2 ESD Ratings

ESD		Value	Unit	
V(ESD)	Electrostatic Discharge	Human-Body Model (HBM) ⁽¹⁾	3 K	V
		Charged-Device Model (CDM) ⁽²⁾	3 K	V

(1) JEDEC document JEP155 states that 500-V HBM allows safe manufacturing with a standard ESD control process.

(2) JEDEC document JEP157 states that 250-V CDM allows safe manufacturing with a standard ESD control process.

5.3 Recommended Operating Conditions

Over operating free-air temperature range (unless otherwise noted)

Symbol	Parameters	Min	Max	Unit
V_{CC}	Single-Supply, $V_S=(V+) - (V-)$	3	36	V
	Dual-Supply, $V_S=(V+) - (V-)$	±1.5	±18	V
TA	Operating Temperature	-40	125	°C

6 Electrical Specifications

$V_S=30V$, and $R_L=10k\Omega$ connected to $V_S/2$, and $V_{OUT}=V_S/2$. Typical values are at $T_A=+25^\circ C$. (unless otherwise noted)

Parameter	Symbol	Test Conditions	Min	Typ	Max	Units
Offset						
Input Offset Voltage	V_{OS}	$(V_S+)=15V, (V_S-)= -15V$	-3	± 0.35	3	mV
V_{OS} VS Temperature	dV_{OS}/dT	$V_S=30V, T_A=-40^\circ C$ to $125^\circ C$		± 2		$\mu V/^\circ C$
Power-Supply Rejection Ratio	PSRR	$V_S=30V, T_A=-40^\circ C$ to $125^\circ C$	70	100		dB
Power supply						
Power Supply	V_S	No load	3		36	V
Quiescent Current/Per	I_Q	No load		100	180	μA
Input						
Common Mode Voltage Range	V_{cm}		(V-)		(V+)-1.5	V
Common Mode Rejection Ratio	CMRR	$(V-) < V_{cm} < (V+) - 1.5$	65	120		dB
Differential Input cap	Input cap			7.7		pF
Common Mode Input cap	Input cap			9		pF
Input Bias Current	I_b	$T_A=-40^\circ C$ to $85^\circ C$		30		pA
Input Offset Current	I_{os}			2		pA
Output						
Voltage Output Swing	V_O	$V_S=30V, I_{out}=-1mA$		0.5	1.5	V
Short Circuit Current	I_{sc}	$V_S=30V$		35		mA
AC						
Open Loop Voltage Gain	A_{OL}		85	100		dB
Slew Rate	SR	$V_S=-15V, V_S+=15V, AV=1, V_{out}=-1V$ to $1V, C_{load}=30pF, R_{load}=10k\Omega$		0.78		$V/\mu S$
Gain-Bandwidth Product	GBW	$V_S=5V$		1.5		MHz
Gain Margin	GM			60		°
Phase Margin	PM			12		dB
Setting time, 0.1%	t_s	$V_S=-15V, V_S+=15V, AV=1, 2-V$ step, $C_{load}=60pF, R_{load}=10k\Omega$				
Noise						
Total Harmonic Distortion+Noise	THD+N	$V_S=30V, AV=1, f=1KHz, R_{load}=10k\Omega, V_{out}=1V_{pp}$		0.002		%
Input Voltage Noise	E_N	$V_S=30V, f=0.1Hz$ to $10Hz$		2.9		μV_{rms}
Input Voltage Noise Density	e_N	$V_S=5V, f=1KHz$		35		nV/\sqrt{Hz}
Input Current Noise Density	I_n	$V_S=5V, f=1KHz$		23		fA/\sqrt{Hz}

7 Typical Characteristics

At $T_A=+25^{\circ}\text{C}$, $V_{CC}=30\text{V}$, $R_L=10\text{K}\Omega$ connected to $V_{CC}/2$, $V_{OUT}=V_{CC}/2$. (unless otherwise noted)

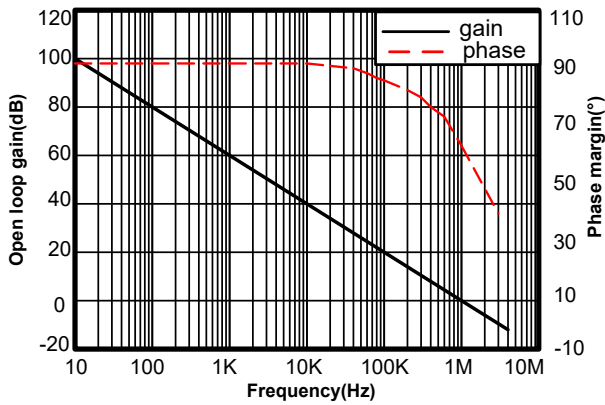

Fig.7-1. Loop Gain and Phase vs Frequency

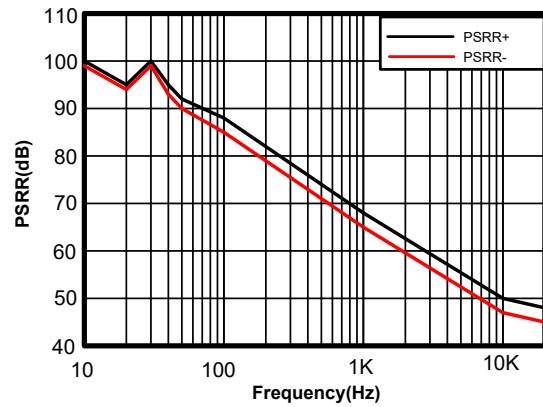

Fig.7-2. PSRR vs Frequency

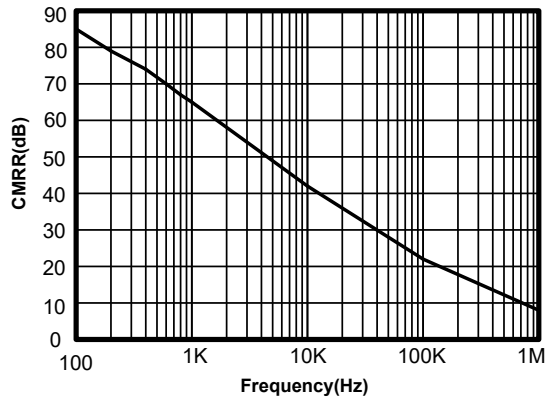

Fig.7-3. CMRR vs Frequency

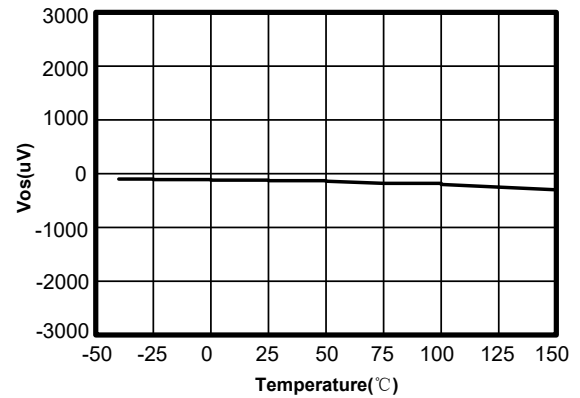

Fig.7-4. Offset Voltage vs Temperature

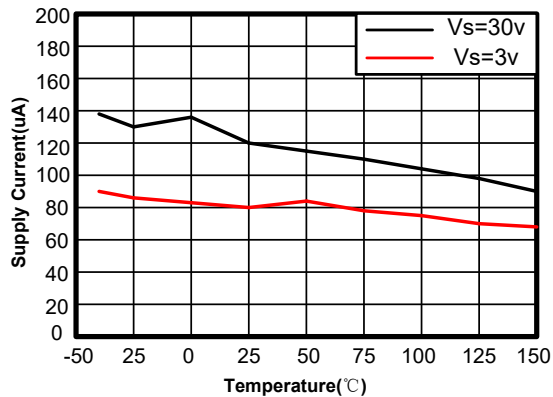

Fig.7-5. Quiescent Current vs Temperature

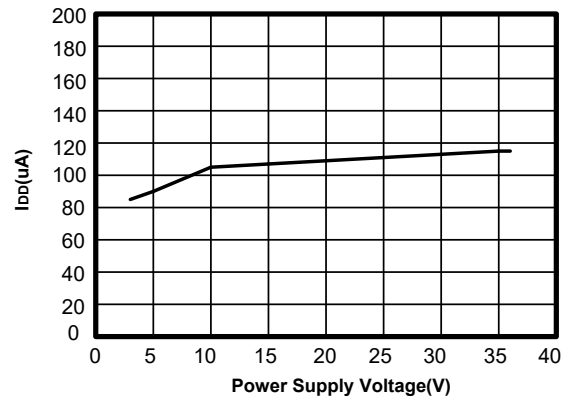

Fig.7-6. IQ vs Power Supply Voltage(25°C)

8 Detailed Description

These devices contain four independent high gain frequency compensation op amps designed for single supply over a wide voltage range. Dual-supply operation is also possible if the voltage difference between the two supplies is between 3V and 36V and V_{CC} is at least 1.5V higher than the positive value of the input common-mode voltage. The low supply current drain is independent of the magnitude of the supply voltage. Applications include sensor amplifiers, DC amplifiers, and all traditional op amp circuits, which can now be more easily implemented in single-supply voltage systems.

The valid common-mode range is from device ground to $V_{CC}-1.5V$ ($V_{CC}-2V$ over temperature). The input may exceed V_{CC} up to the maximum V_{CC} without damaging the device. At least one input must be within a valid input common-mode range for the output to have the correct phase. If both inputs are outside the valid range, the output phase is undefined. If either input is below $-0.3V$, the input current should be limited to 1mA and the output phase should be undefined.

Slew rate is the rate at which the op amp can change the output when the input changes. Slew rates are better for different occasions, sometimes bigger is better, sometimes smaller is better, OSU6321, OSU6358, OSU6324, these devices have a slew rate of 1.0 V/ μ S.

The gain-bandwidth product is equal to the measured amplifier bandwidth multiplied by the gain corresponding to the measured bandwidth. For op amps, the increase in bandwidth means an increase in speed, but at the same time it brings a large amount of power consumption, for general occasions, the bandwidth around 1MHz can take into account the balance of all aspects of the op amp parameters, these devices have a high gain bandwidth of 1.0MHz.

OSU6321, OSU6358, OSU6324 features a low input offset voltage as low as 0.35mV typical from a high voltage supply because the input offset voltage is amplified by noise gain, creating offset errors at the output. For a high-voltage general-purpose op amp, the application scenarios and scope of the op amp are maximized while minimizing the design of the low offset voltage while taking into account other op amp parameters. It is especially suitable for some occasions with high sensitivity.

9 Application Note

Op amps are suitable for a variety of signal conditioning applications. The input can be powered before V_s , allowing flexibility in multiple supply circuits. The amplifier accepts a positive voltage at the input and then changes the voltage to a negative voltage of the same magnitude. It also turns the negative input voltage into positive in the same way.

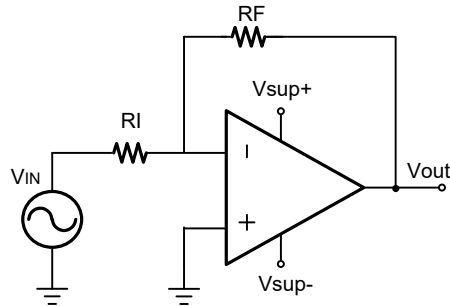
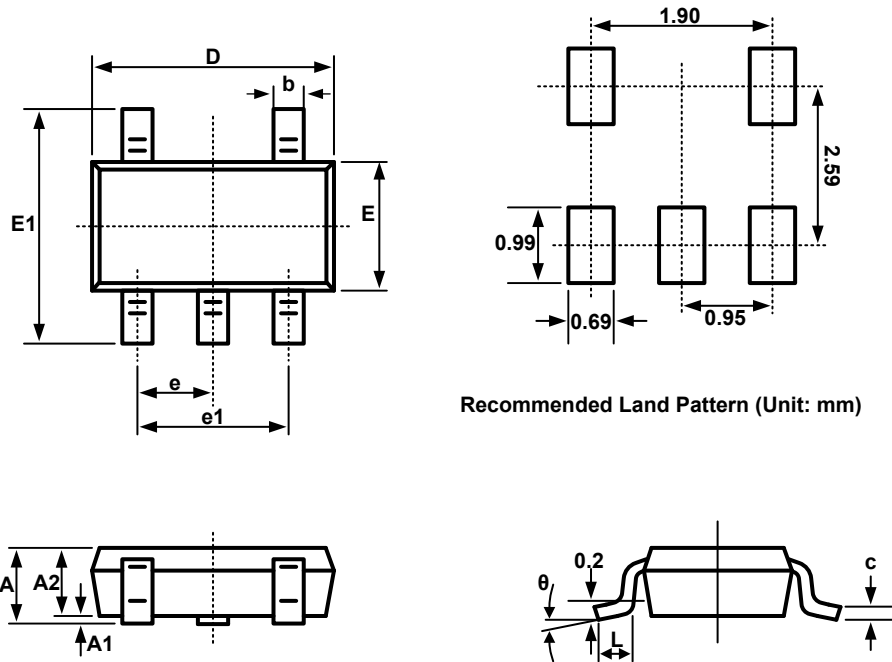

Fig.9-1. Dual-Supply Amplifier

10 Package Outline Dimension

SOT23-5



Symbol	Dimensions in Millimeters		Dimensions in Inches	
	Min.	Max.	Min.	Max.
A	1.050	1.250	0.041	0.049
A1	0.000	0.100	0.000	0.004
A2	1.050	1.150	0.041	0.045
b	0.300	0.500	0.012	0.020
c	0.100	0.200	0.004	0.008
D	2.820	3.020	0.111	0.119
E	1.500	1.700	0.059	0.067
E1	2.650	2.950	0.104	0.116
e	0.950(BSC)		0.037(BSC)	
e1	1.800	2.000	0.071	0.079
L	0.300	0.600	0.012	0.024
θ	0°	8°	0°	8°
Symbol	Dimensions in Millimeters		Dimensions in Inches	

10 Package Outline Dimension(Continued)

SOP8

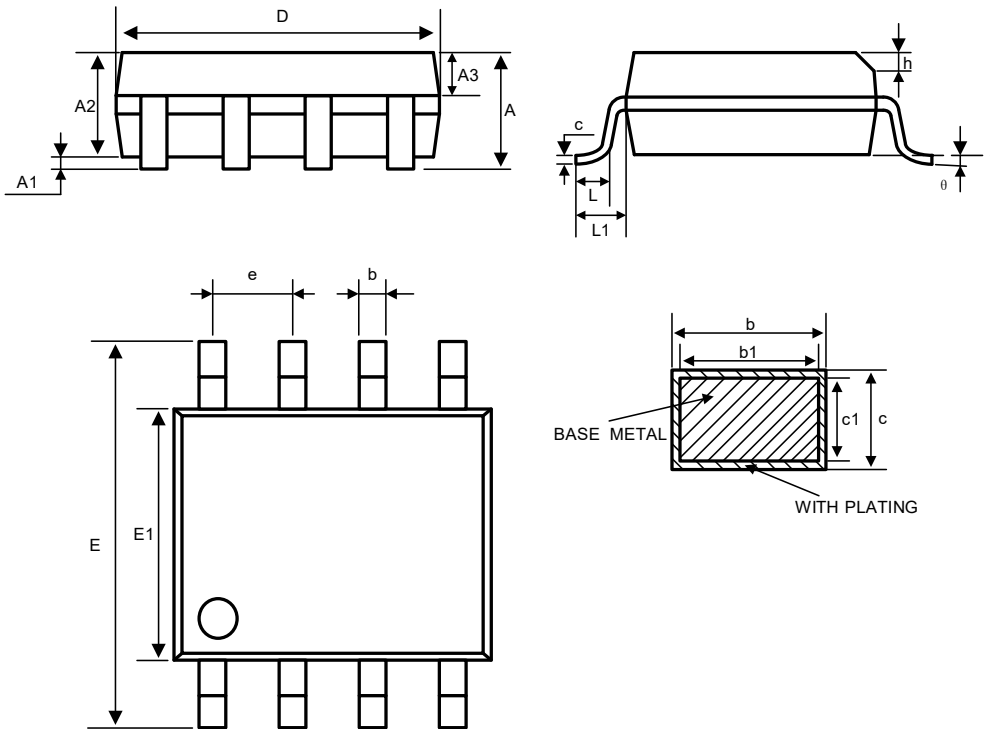

Symbol	Dimensions in Millimeters			Dimensions in Inches		
	Min.	Nom.	Max.	Min.	Nom.	Max.
A	—	—	1.75	—	—	0.069
A1	0.10	—	0.225	0.004	—	0.009
A2	1.30	1.40	1.50	0.051	0.055	0.059
A3	0.60	0.65	0.70	0.024	0.026	0.028
b	0.39	—	0.47	0.015	—	0.019
b1	0.38	0.41	0.44	0.015	0.016	0.017
c	0.20	—	0.24	0.008	—	0.009
c1	0.19	0.20	0.21	0.007	0.008	0.008
D	4.80	4.90	5.00	0.189	0.193	0.197
E	5.80	6.00	6.20	0.228	0.236	0.244
E1	3.80	3.90	4.00	0.150	0.154	0.157
e	1.27BSC			0.05BSC		
h	0.25	—	0.50	0.010	—	0.020
L	0.50	—	0.80	0.020	—	0.031
L1	1.05REF			0.041REF		
θ	0	—	8°	0	—	8°

10 Package Outline Dimension(Continued)

TSSOP8

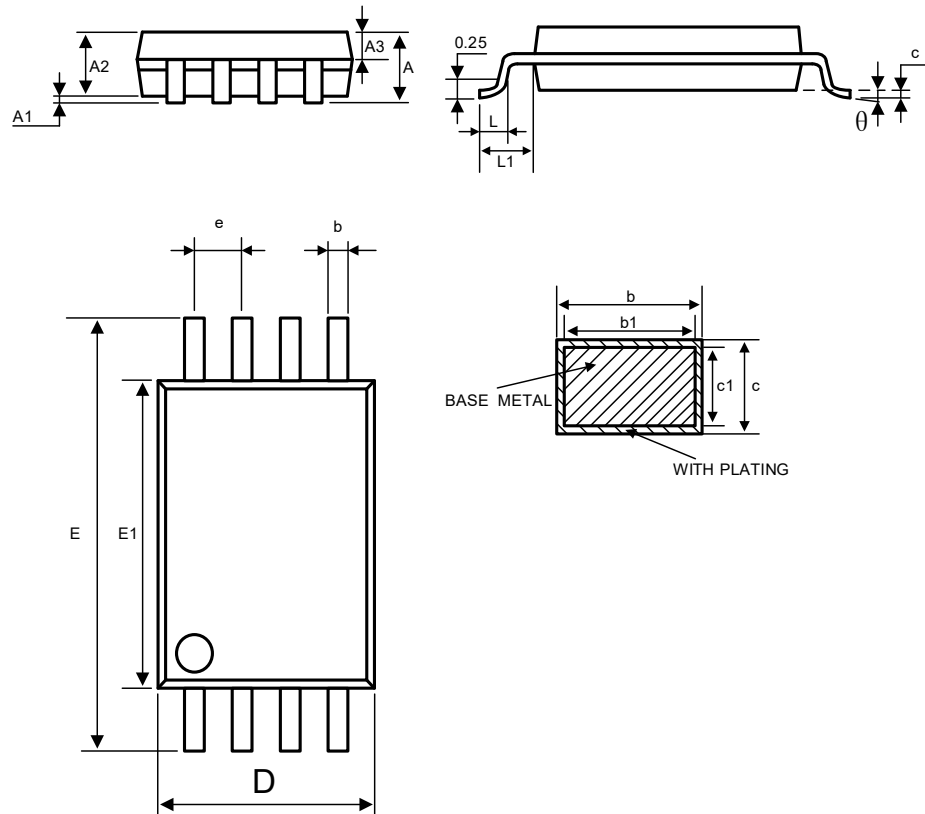

Symbol	Dimensions in Millimeters			Dimensions in Inches		
	Min.	Nom.	Max.	Min.	Nom.	Max.
A	—	—	1.20	—	—	0.047
A1	0.05	—	0.15	0.002	—	0.006
A2	0.90	1.00	1.05	0.035	0.039	0.041
A3	0.39	0.44	0.49	0.015	0.017	0.019
b	0.20	—	0.28	0.008	—	0.011
b1	0.19	0.22	0.25	0.007	0.009	0.010
c	0.13	—	0.17	0.005	—	0.007
c1	0.12	0.13	0.14	0.005	0.005	0.006
D	2.90	3.00	3.10	0.114	0.118	0.122
E1	4.30	4.40	4.50	0.169	0.173	0.177
E	6.20	6.40	6.60	0.244	0.251	0.260
e	0.65BSC			0.026BSC		
L	0.45	—	0.75	0.018	—	0.030
L1	1.00REF			0.039REF		
θ	0	—	8°	0	—	8°

10 Package Outline Dimension(Continued)

DFN2×2-8L

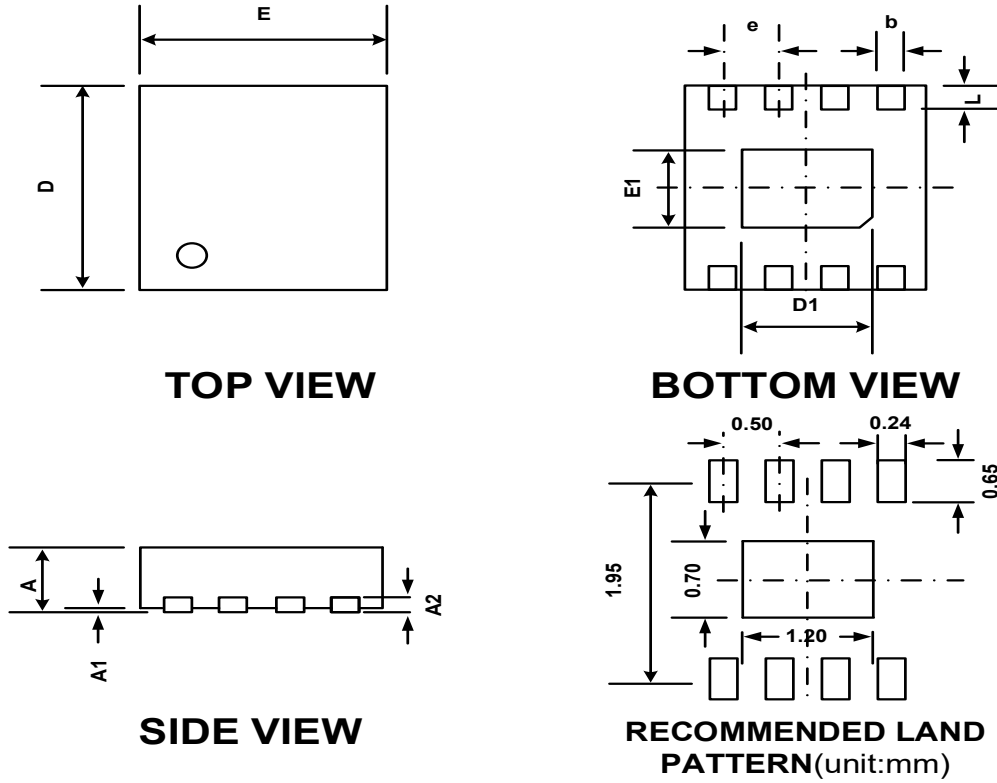

Symbol	Dimensions in Millimeters		Dimensions in Inches	
	Min.	Max.	Min.	Max.
A	0.700	0.800	0.028	0.031
A1	0.000	0.050	0.000	0.002
A2	0.203(TYP)		0.035(TYP)	
b	0.180	0.300	0.007	0.012
D	1.900	2.100	0.075	0.083
D1	1.100	1.300	0.043	0.051
E	1.900	2.100	0.075	0.083
E1	0.600	0.800	0.024	0.031
e	0.500(TYP)		0.020TYP	
L	0.250	0.450	0.010	0.018

10 Package Outline Dimension(Continued)

MSOP8

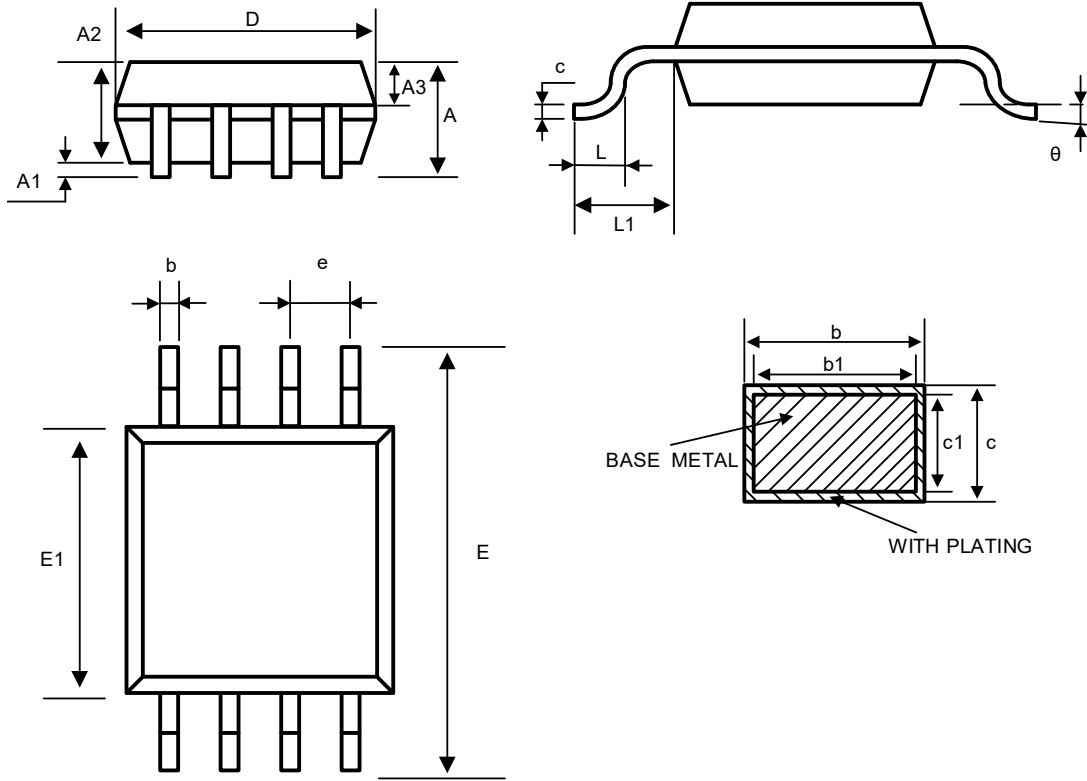

Symbol	Dimensions in Millimeters			Dimensions in Inches		
	Min.	Nom.	Max.	Min.	Nom.	Max.
A	—	—	1.10	—	—	0.043
A1	0.05	—	0.15	0.002	—	0.006
A2	0.75	0.85	0.95	0.030	0.033	0.037
A3	0.30	0.35	0.40	0.012	0.014	0.016
b	0.28	—	0.36	0.011	—	0.014
b1	0.27	0.30	0.33	0.011	0.012	0.013
c	0.15	—	0.19	0.006	—	0.007
c1	0.14	0.15	0.16	0.006	0.006	0.006
D	2.90	3.00	3.10	0.114	0.118	0.122
E	4.70	4.90	5.10	0.185	0.193	0.201
E1	2.90	3.00	3.10	0.114	0.118	0.122
e	0.65BSC			0.026BSC		
L	0.40	—	0.70	0.016	—	0.028
L1	0.95REF			0.037REF		
θ	0	—	8°	0	—	8°

10 Package Outline Dimension(Continued)

SOP14

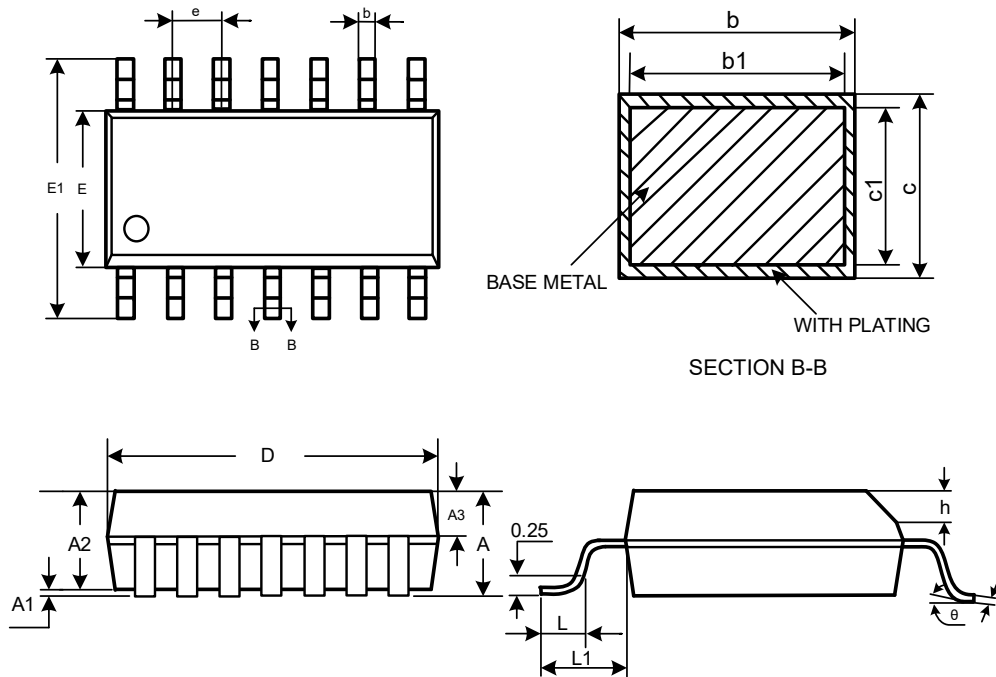

Symbol	Dimensions in Millimeters			Dimensions in Inches		
	Min	Nom	Max	Min	Nom	Max
A	—	—	1.75	—	—	0.069
A1	0.10	—	0.225	0.004	—	0.009
A2	1.30	1.40	1.50	0.051	0.055	0.059
A3	0.60	0.65	0.70	0.024	0.026	0.028
b	0.39	—	0.47	0.015	—	0.019
b1	0.38	0.41	0.44	0.015	0.016	0.017
c	0.20	—	0.24	0.008	—	0.009
c1	0.19	0.20	0.21	0.007	0.008	0.008
D	8.55	8.65	8.75	0.337	0.341	0.344
E1	5.80	6.00	6.20	0.228	0.236	0.244
E	3.80	3.90	4.00	0.150	0.154	0.157
e	1.27BSC			0.05BSC		
h	0.25	—	0.50	0.010	—	0.020
L	0.50	—	0.80	0.020	—	0.031
L1	1.05REF			0.041REF		
θ	0	—	8°	0	—	8°

10 Package Outline Dimension(Continued)

TSSOP14

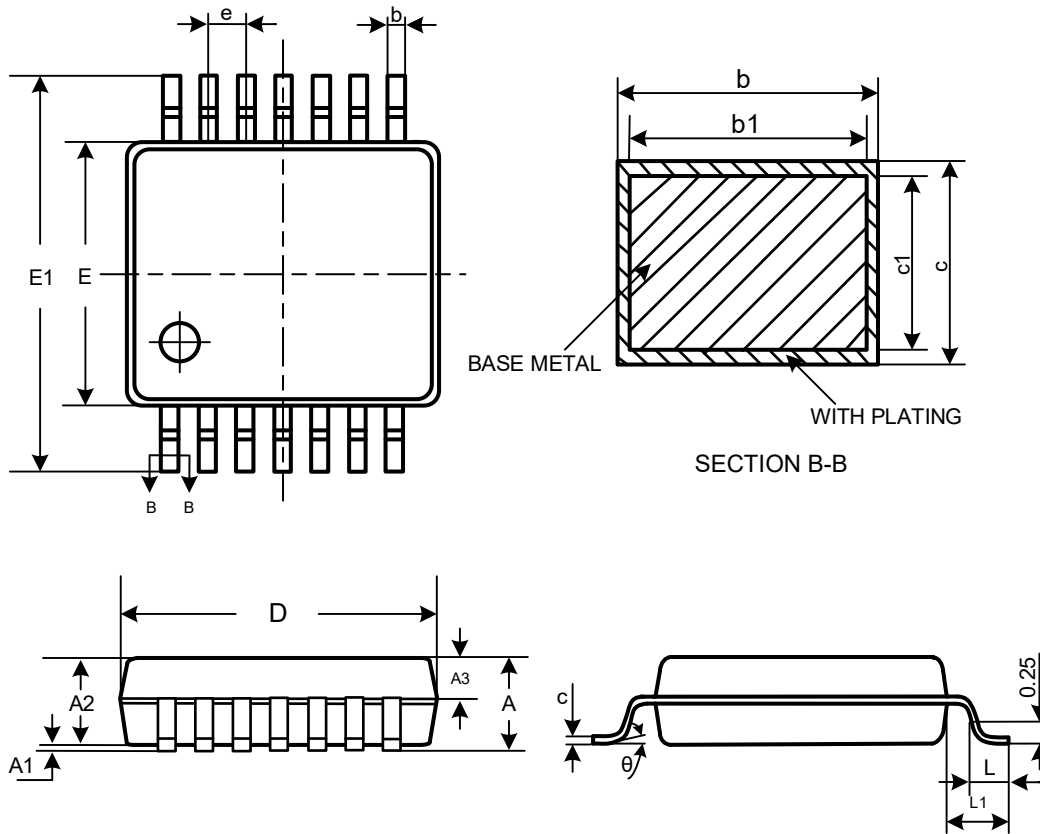

Symbol	Dimensions in Millimeters			Dimensions in Inches		
	Min	Nom	Max	Min	Nom	Max
A	—	—	1.20	—	—	0.047
A1	0.05	—	0.15	0.002	—	0.006
A2	0.90	1.00	1.05	0.035	0.039	0.041
A3	0.39	0.44	0.49	0.015	0.017	0.019
b	0.20	—	0.28	0.008	—	0.011
b1	0.19	0.22	0.25	0.007	0.009	0.010
c	0.13	—	0.17	0.005	—	0.007
c1	0.12	0.13	0.14	0.005	0.005	0.006
D	4.90	5.00	5.10	0.193	0.197	0.201
E	4.30	4.40	4.50	0.169	0.173	0.177
E1	6.20	6.40	6.60	0.244	0.252	0.260
e	0.65BSC			0.026BSC		
L	0.45	0.60	0.75	0.018	0.024	0.030
L1	1.00BCS			0.039BSC		
θ	0	—	8°	0	—	8°

11 Tape and Reel Information

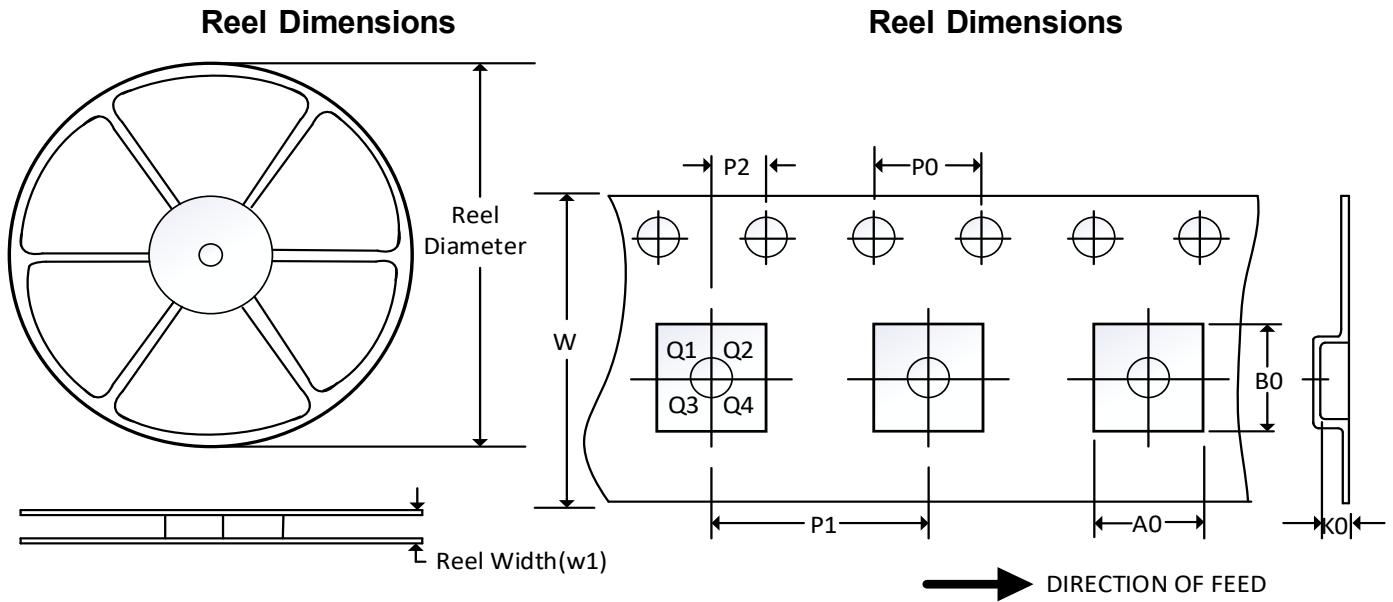

NOTE: The picture is only for reference. Please make the object as the standard.

Key Parameter List of Tape and Reel

Package Type	Reel Diameter	Reel Width (mm)	A0 (mm)	B0 (mm)	K0 (mm)	P0 (mm)	P1 (mm)	P2 (mm)	W (mm)	Pin1 Quadrant
SOT23-5	7"	9.5	3.20	3.20	1.40	4.0	4.0	2.0	8.0	Q3
MSOP8	13"	12.4	5.20	3.30	1.50	4.0	8.0	2.0	12.0	Q1
TSSOP14	13"	12.4	6.95	5.60	1.20	4.0	8.0	2.0	12.0	Q1
SOP8	13"	12.4	6.40	5.40	2.10	4.0	8.0	2.0	12.0	Q1
TSSOP8	13"	12.4	6.90	3.45	1.65	4.0	8.0	2.0	12.0	Q1
DFN2x2-8L	7"	9.5	2.30	2.30	1.0	4.0	4.0	2.0	8.0	Q2
SOP14	13"	16.4	6.60	9.30	2.10	4.0	8.0	2.0	16.0	Q1

NOTE:

1. All dimensions are nominal.
2. Plastic or metal protrusions of 0.15mm maximum per side are not included.

Legal Disclaimer

The information given in this document shall in no event be regarded as a guarantee of conditions or characteristics. With respect to any examples or hints given herein, any typical values stated herein and/or any information regarding the application of the device, Oriental Semiconductor hereby disclaims any and all warranties and liabilities of any kind, including without limitation, warranties of non-infringement of intellectual property rights of any third party.

For further information on technology, delivery terms and conditions and prices, please contact the Oriental Semiconductor sales representatives (www.orientalsemi.com).

© Oriental Semiconductor Co.,Ltd. All Rights Reserved 