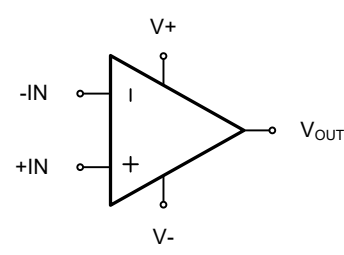

OSU6021 OSU6022 OSU6024 50MHz, Rail-to-Rail Output CMOS Operational Amplifier

1 Features	2 Application
<ul style="list-style-type: none"> - High gain bandwidth: 50 MHz - Rail-to-rail output - 1.5 mV typical Vos - High slew rate: 75 V/μs - High output current: > 100 mA - Supply range: +2.5 V to +5.5 V - Quiescent current: 3 mA per amplifier 	<ul style="list-style-type: none"> - Audio ADC input buffers - Active filters - High-density systems - Video processing - Driving A/D converters

3 Description	Circuit Diagram
<p>The OSU602X series of high-speed, voltage-feedback CMOS operational amplifiers are designed for video and other applications requiring wide bandwidth. They are unity-gain stable and can drive large output currents. Quiescent current is only 3mA per channel. The OSU602X series of op amps are optimized for operation on single or dual supplies as low as 2.5V ($\pm 1.25V$) and up to 5.5V ($\pm 2.75V$). Common-mode input range extends beyond the supplies. The output swing is within 30mV of the rails, supporting wide dynamic range.</p> <p>All features are specified over the extended $-40^{\circ}C$ to $+125^{\circ}C$ temperature range.</p>	

4 Device Summary, Pin and Packages

Table 5-1. Device Summary⁽¹⁾

Serial Name	Part Name	Package	Body Size (Nom)	Marking ⁽²⁾	MSL ⁽³⁾	Package Qty
OSU6021	OSU6021C5	SC70-5	2.10mm×1.25mm×1.00mm	OSU6021 XXXXXX	3	Tape and Reel,3000
	OSU6021BC5	SC70-5	2.10mm×1.25mm×1.00mm	OSU6021B XXXXXX	3	Tape and Reel,3000
	OSU6021S5	SOT23-5	2.90mm×1.60mm×1.10mm	OSU6021 XXXXXX	3	Tape and Reel,3000
	OSU6021BS5	SOT23-5	2.90mm×1.60mm×1.10mm	OSU6021B XXXXXX	3	Tape and Reel,3000
	OSU6021M8	MSOP8	3.00mm×3.00mm×1.10mm	OSU6021 XXXXXXXX	3	Tape and Reel,4000
	OSU6021P8	SOP8	6.00mm×3.90mm×1.75mm	OSU6021 XXXXXXXX	3	Tape and Reel,4000
OSU6022	OSU6022M8	MSOP8	3.00mm×3.00mm×1.10mm	OSU6022 XXXXXXXX	3	Tape and Reel,4000
	OSU6022T8	TSSOP8	3.00mm×4.40mm×1.10mm	OSU6022 XXXXXXXX	3	Tape and Reel,4000
	OSU6022P8	SOP8	6.00mm×3.90mm×1.75mm	OSU6022 XXXXXXXX	3	Tape and Reel,4000
OSU6024	OSU6024TD	TSSOP14	5.00mm×4.40mm×1.20mm	OSU6024 XXXXXXXX	3	Tape and Reel,4000
	OSU6024PD	SOP14	8.65mm×3.90mm×1.75mm	OSU6024 XXXXXXXX	3	Tape and Reel,4000

(1) For all available packages, please contact product sales.

(2) There may be additional marking, which relates to the lot trace code information (data code and vendor code), the logo or the environmental category on the device.

(3) MSL, The Moisture Sensitivity Level rating according to the JEDEC industry standard classifications.

(4) "XXXXXX" in Marking will be appeared as the batch code.

4 Device Summary, Pin and Packages(Continued)

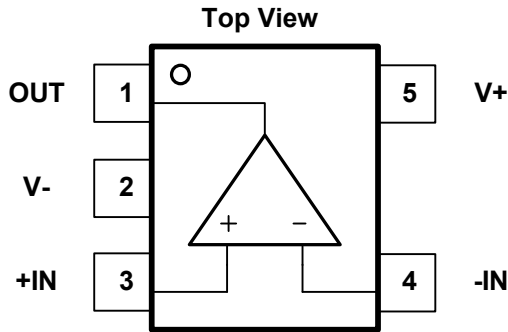

Fig.5-1. OSU6021: C5(SC70-5) Package
OSU6021: S5(SOT23-5) Package

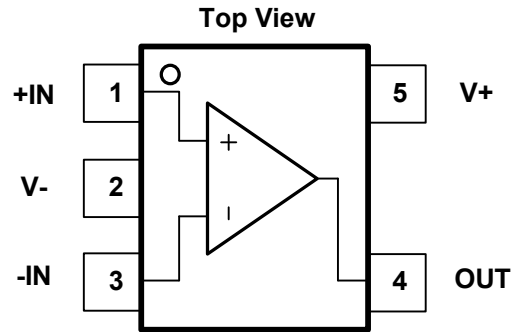

Fig.5-2. OSU6021: BC5(SC70-5) Package
OSU6021: BS5(SOT23-5) Package

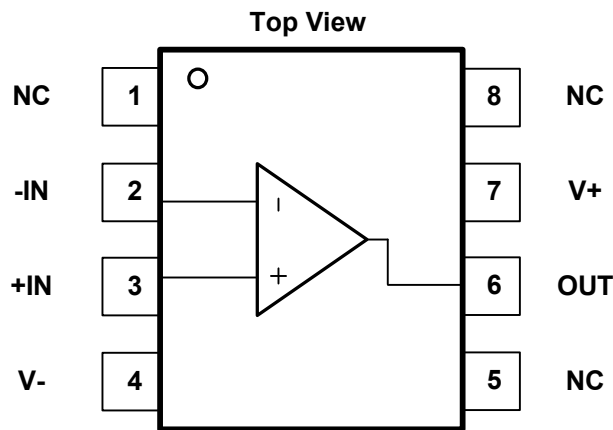

Fig.5-3. OSU6021: M8(MSOP8) Package
OSU6021: P8(SOP8) Package

Table 5-2 Pin Definition

Name	Pin			I/O	Description
	C5 S5	BC5 BS5	P8 M8		
-IN	4	3	2	I	Negative (inverting) input
+IN	3	1	3	I	Positive(noninverting) input
NC	-	-	1,5,8	-	No internal connection (can be left floating)
OUT	1	4	6	O	Output
V-	2	2	4	-	Negative (lowest) power supply
V+	5	5	7	-	Positive (highest) power supply

* It is suggested to leave the unconnected pins floating.

4 Device Summary, Pin and Packages(Continued)

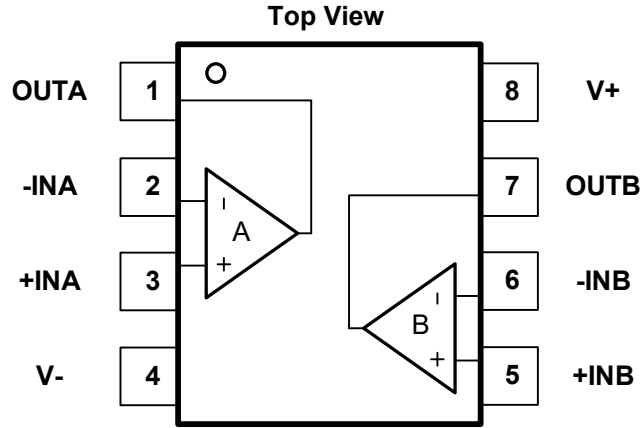

Fig.5-4. OSU6022: P8(SOP8) Package

OSU6022: M8(MSOP8) Package

OSU6022: T8(TSSOP8) Package

Table 5-3 Pin Definition

Name	Pin			I/O	Description
	P8	M8	T8		
-INA	2			I	Inverting input, channel A
+INA	3			I	Noninverting input, channel A
-INB			6	I	Inverting input, channel B
+INB			5	I	Noninverting input, channel B
OUTA	1			O	Output, channel A
OUTB			7	O	Output, channel B
V-			4	-	Negative (lowest) power supply
V+			8	-	Positive (highest) power supply

* It is suggested to leave the unconnected pins floating.

4 Device Summary, Pin and Packages(Continued)

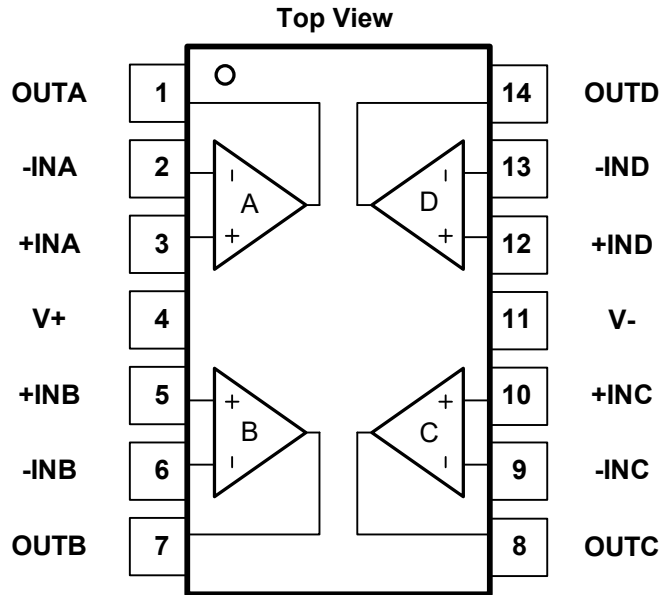

Fig.5-5. OSU6024: TD(TSSOP14) Package

OSU6024: PD(SOP14) Package

Table 5-4 Pin Definition

Name	Pin		I/O	Description
	PD	TD		
-INA	2		I	Inverting input, channel A
+INA	3		I	Noninverting input, channel A
-INB	6		I	Inverting input, channel B
+INB	5		I	Noninverting input, channel B
-INC	9		I	Inverting input, channel C
+INC	10		I	Noninverting input, channel C
-IND	13		I	Inverting input, channel D
+IND	12		I	Noninverting input, channel D
OUTA	1		O	Output, channel A
OUTB	7		O	Output, channel B
OUTC	8		O	Output, channel C
OUTD	14		O	Output, channel D
V-	11		-	Negative (lowest) power supply
V+	4		-	Positive (highest) power supply

* It is suggested to leave the unconnected pins floating.

5 Voltage, Temperature, ESD and Thermal ratings

5.1 Absolute Maximum Ratings⁽¹⁾

Parameters	Min.	Max.	Unit
Supply Voltage, $V_S=(V+) - (V-)$		6.5	V
Select Input Voltage ⁽²⁾	(V-)-0.5	(V+)+0.5	V
Maximum Junction Temperature	-55	150	°C
Storage Temperature Range	-55	150	°C

(1) Stresses above these ratings may cause permanent damage. Exposure to absolute maximum conditions for extended periods may degrade device reliability. These are stress ratings only, and functional operation of the device at these or any other conditions beyond those specified is not implied.

(2) Input terminals are diode-clamped to the power-supply rails. Input signals that can swing more than 0.3V beyond the supply rails should be current-limited to 10mA or less.

5.2 ESD Ratings

ESD		Value	Unit
V(ESD)	Electrostatic Discharge	Human-body Model (HBM) ⁽¹⁾	5 K
		Charged Device Model (CDM) ⁽²⁾	2 K

(1) JEDEC document JEP155 states that 500-V HBM allows safe manufacturing with a standard ESD control process.

(2) JEDEC document JEP157 states that 250-V CDM allows safe manufacturing with a standard ESD control process.

5.3 Recommended Operating Conditions

Over operating free-air temperature range (unless otherwise noted)

Symbol	Parameters	Min	Max	Unit
V_{CC}	Single-Supply, $V_S=(V+) - (V-)$	2.5	5.5	V
	Dual-Supply, $V_S=(V+) - (V-)$	±1.25	±2.75	V
TA	Operating Temperature	-40	125	°C

5.4 Thermal Information

Package Type	θ_{JA}	θ_{JC}	Unit
SC70-5	400	150	°C/W
SOT23-5	250	81	°C/W
MSOP8	210	45	°C/W
SOP8	158	43	°C/W
TSSOP8	191	50	°C/W
TSSOP14	180	35	°C/W
SOP14	120	36	°C/W

6 Electrical Specifications

$V_{CC}=5V$, $G=+2$, $R_F=1k\Omega$, and $R_L=1k\Omega$ connected to $V_{CC}/2$, $V_{IN_CM}=V_{CC}/2$. FULL= $-40^{\circ}C$ to $+125^{\circ}C$. Typical values are at $T_A=+25^{\circ}C$. (unless otherwise noted)

Parameter	Symbol	Test Conditions	Vcc	TA	Min	Typ	Max	Units
Power Supply								
Operating Voltage	V_s		2.5V to 5.5V	FULL	2.5		5.5	V
Quiescent Current (per Amplifier)	IQ	$T_A=25^{\circ}C$, $V_{CC}=5V$, $I_o=0$ $T_A=-40^{\circ}C$ to $+125^{\circ}C$	5V	+25°C		3		mA
				FULL			5.5	mA
Power-Supply Rejection Ratio	PSRR	$V_{CC}=2.5V$ to $5.5V$, $V_{CM}=(V_-)+0.5V$	2.5V to 5.5V	+25°C	70	95		dB
Input								
Input Bias Current	I_b		5V	+25°C		± 1	± 10	pA
Input Offset Current	I_{os}		5V	+25°C		± 1	± 10	pA
Input Offset Voltage	V_{os}	$V_{CC}=5V$	5V	+25°C		± 1.5	± 6.5	mV
				FULL			± 7	mV
Input Offset Voltage vs Temperature	dV_{os}/dT	$V_{CC}=5V$	5V	FULL		4		$\mu V/^{\circ}C$
Input Impedance	Differential		5V	+25°C		$10^{13} 0.25$		ΩpF
	Common-Mode		5V	+25°C		$10^{13} 2.55$		ΩpF
Common-Mode Voltage	V_{CM}	$V_{CC}=5V$	5V	FULL	-0.3		3.6	V
Common-Mode Rejection Ratio	CMRR	$V_{CC}=5.5V$, $-0.1V < V_{CM} < 3.5V$	5.5V	+25°C	66	85		dB
Input Voltage Noise Density	e_n	$f=1MHz$	2.5V to 5.5V	+25°C		4		nV/ \sqrt{Hz}
Open-loop Gain								
Open-Loop Gain	A_{OL}	$V_{CC}=5V, V_o=4.8V, R_L=1k\Omega$	5V	FULL	90	105		dB
		$V_{CC}=5V, V_o=4.7V, R_L=150\Omega$	5V	FULL	85	90		dB

6 Electrical Specifications(Continued)

$V_{CC}=5V$, $G=+2$, $R_F=1k\Omega$, and $R_L=1k\Omega$ connected to $V_{CC}/2$, $V_{IN_CM}=V_{CC}/2$. FULL= $-40^{\circ}C$ to $+125^{\circ}C$. Typical values are at $T_A=+25^{\circ}C$. (unless otherwise noted)

Parameter	Symbol	Test Conditions	Vcc	TA	Min	Typ	Max	Units
Frequency Response								
Small-Signal Bandwidth	f_{-3dB}	At $G=+1$, $V_O=100mV_{PP}$, $R_F=25\Omega$	5V	$+25^{\circ}C$		50		MHz
		At $G=+2$, $V_O=100mV_{PP}$, $R_F=1k\Omega$	5V	$+25^{\circ}C$		30		MHz
		At $G=+5$, $V_O=100mV_{PP}$, $R_F=4k\Omega$	5V	$+25^{\circ}C$		9		MHz
		At $G=+10$, $V_O=100 mV_{PP}$, $R_F=9k\Omega$	5V	$+25^{\circ}C$		4		MHz
Slew Rate	SR	$V_{CC}=5V$, $G=+2$, 4-V Step Output	5V	$+25^{\circ}C$		75		V/ μs
Output								
Voltage Output Swing From Rail	SWING	$R_L=1k\Omega$	2.5V to 5.5V	FULL		30		mV
Output Current Source	I_{O_SOURCE}	$V_{CC}=5V$	5V	$+25^{\circ}C$		100		mA
Output Current Sink	I_{O_SINK}	$V_{CC}=5V$	5V	$+25^{\circ}C$		100		mA

7 Typical Characteristics

$V_{CC}=5V$, $G=+2$, $R_F=1K\Omega$, and $R_L=1K\Omega$ connected to $V_{CC}/2$, $V_{IN_CM}=V_{CC}/2$. $T_A=+25^\circ C$. (unless otherwise noted)

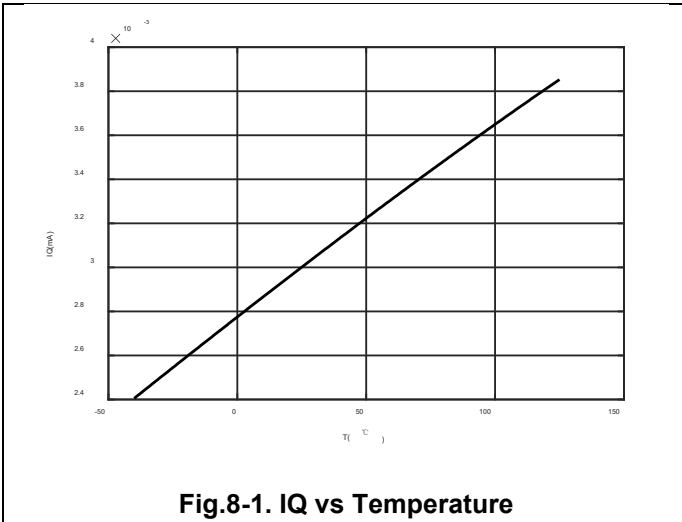

Fig.8-1. IQ vs Temperature

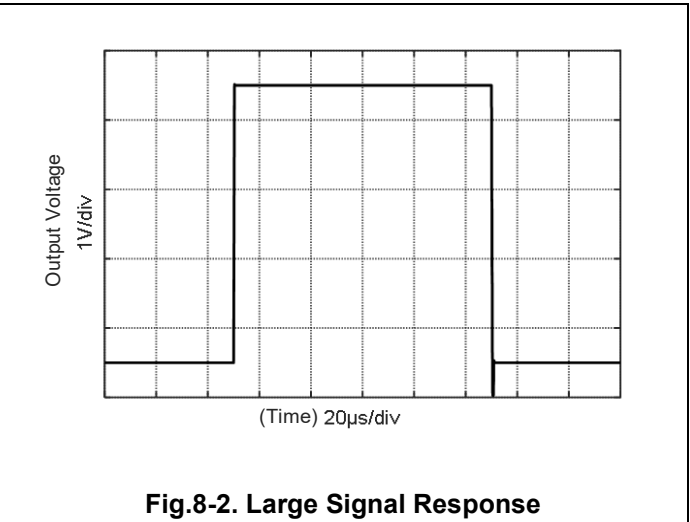

Fig.8-2. Large Signal Response

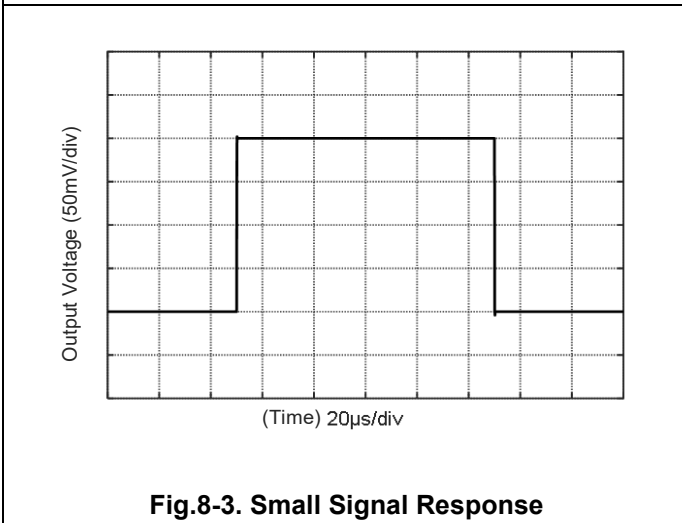

Fig.8-3. Small Signal Response

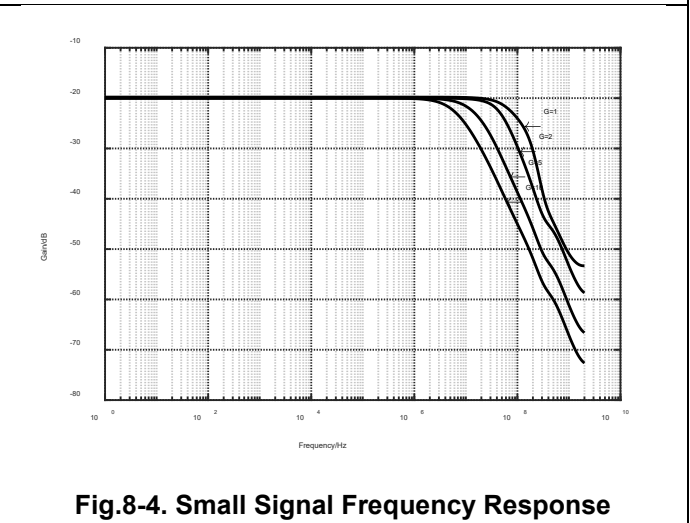

Fig.8-4. Small Signal Frequency Response

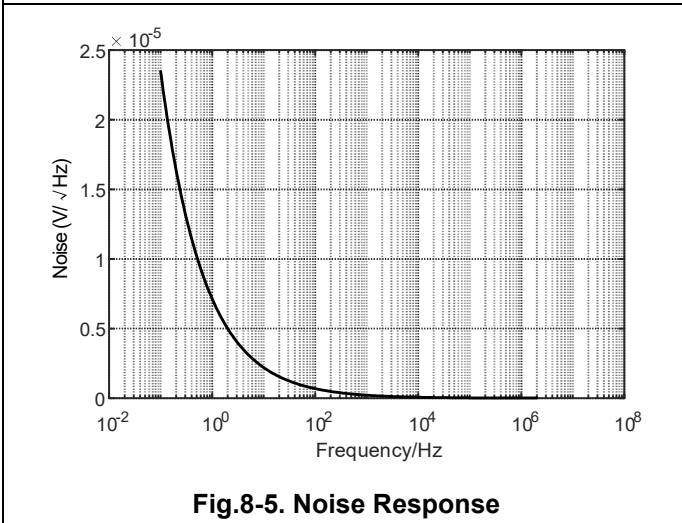

Fig.8-5. Noise Response

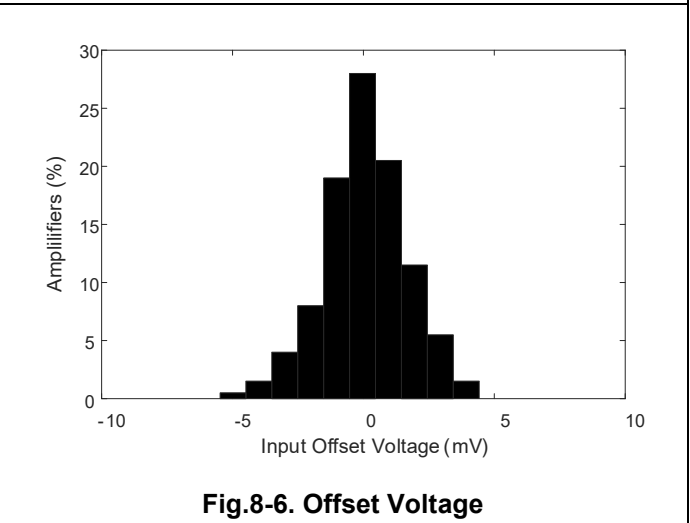

Fig.8-6. Offset Voltage

8 Detailed Description

The OSU602X is a CMOS, rail-to-rail output, high-speed, voltage feedback operational amplifier designed for video, high-speed, and other applications. It is available as a single, dual, or quad op amp. The amplifier features a 50-MHz gain bandwidth, and 75-V/ μ s slew rate.

A class AB output stage with common-source transistors achieves rail-to-rail output. For high-impedance loads ($>200 \Omega$), the output voltage swing is typically 30mV from the supply rails. With 10- Ω loads, a useful output swing is achieved while maintaining high open-loop gain.

9 Application Note

Wide gain bandwidth, low input bias current, low input voltage, and current noise make the OSU602X family of devices an ideal wideband photodiode transimpedance amplifier. Low-voltage noise is important because photodiode capacitance causes the effective noise gain of the circuit to increase at high frequency. The key elements to a transimpedance design, as shown in Figure.10-1, are the expected diode capacitance, (which include the parasitic input common-mode and differential-mode input capacitance) the desired transimpedance gain, and the gain-bandwidth (GBW) for the OSU602X family of devices (50MHz). With these three variables set the feedback capacitor value is set to control the frequency response. Feedback capacitance includes the stray capacitance, which is 0.2pF for a typical surface-mount resistor.

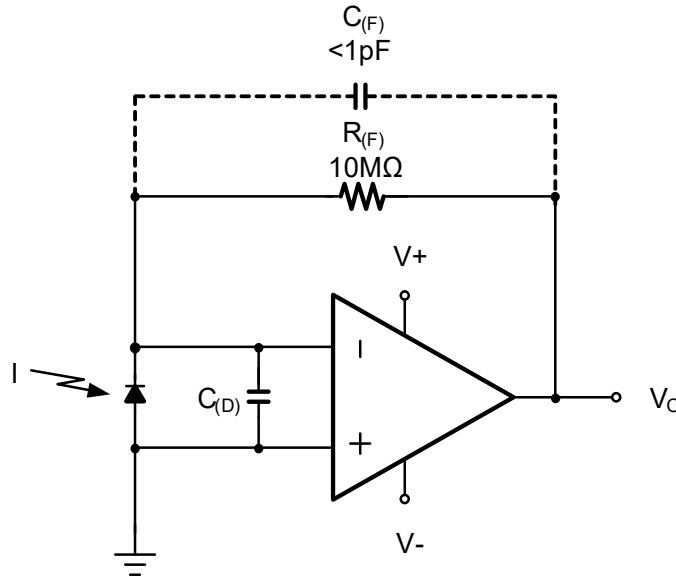
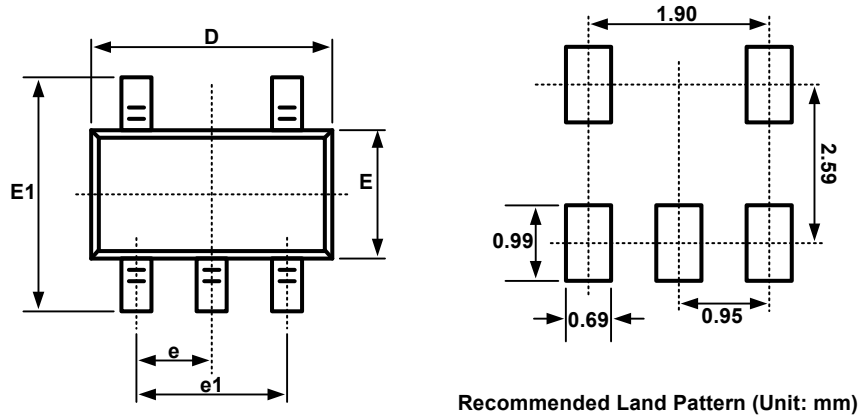

Fig.10-1. Dual-Supply Amplifier

10 Package Outline Dimension

SOT23-5



Recommended Land Pattern (Unit: mm)

Symbol	Dimensions In Millimeters		Dimensions In Inches	
	Min	Max	Min	Max
A	1.050	1.250	0.041	0.049
A1	0.000	0.100	0.000	0.004
A2	1.050	1.150	0.041	0.045
b	0.300	0.500	0.012	0.020
c	0.100	0.200	0.004	0.008
D	2.820	3.020	0.111	0.119
E	1.500	1.700	0.059	0.067
E1	2.650	2.950	0.104	0.116
e	0.950BSC		0.037BSC	
e1	1.800	2.000	0.071	0.079
L	0.300	0.600	0.012	0.024
L1	0.600REF		0.024REF	
θ	0°	8°	0°	8°

10 Package Outline Dimension(Continued)

SC70-5

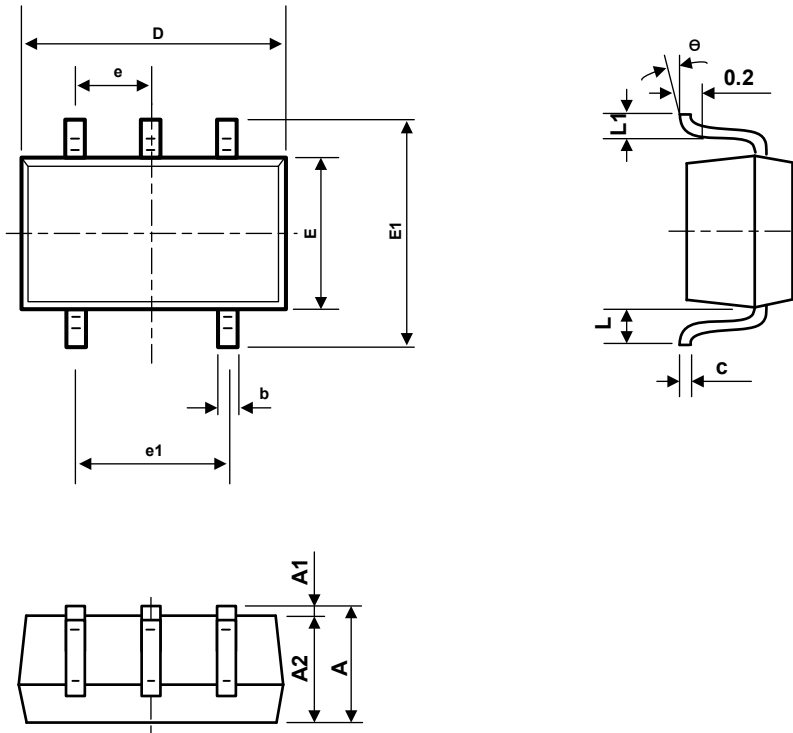

Symbol	Dimensions In Millimeters		Dimensions In Inches	
	Min	Max	Min	Max
A	0.900	1.100	0.035	0.043
A1	0.000	0.100	0.000	0.004
A2	0.900	1.000	0.035	0.039
b	0.150	0.350	0.006	0.014
c	0.110	0.175	0.004	0.007
D	2.000	2.200	0.079	0.087
E	1.150	1.350	0.045	0.053
E1	2.150	2.450	0.085	0.096
e	0.650TYP		0.026TYP	
e1	1.200	1.400	0.047	0.055
L	0.525REF		0.021REF	
L1	0.260	0.460	0.010	0.018
θ	0°	8°	0°	8°

10 Package Outline Dimension(Continued)

SOP8

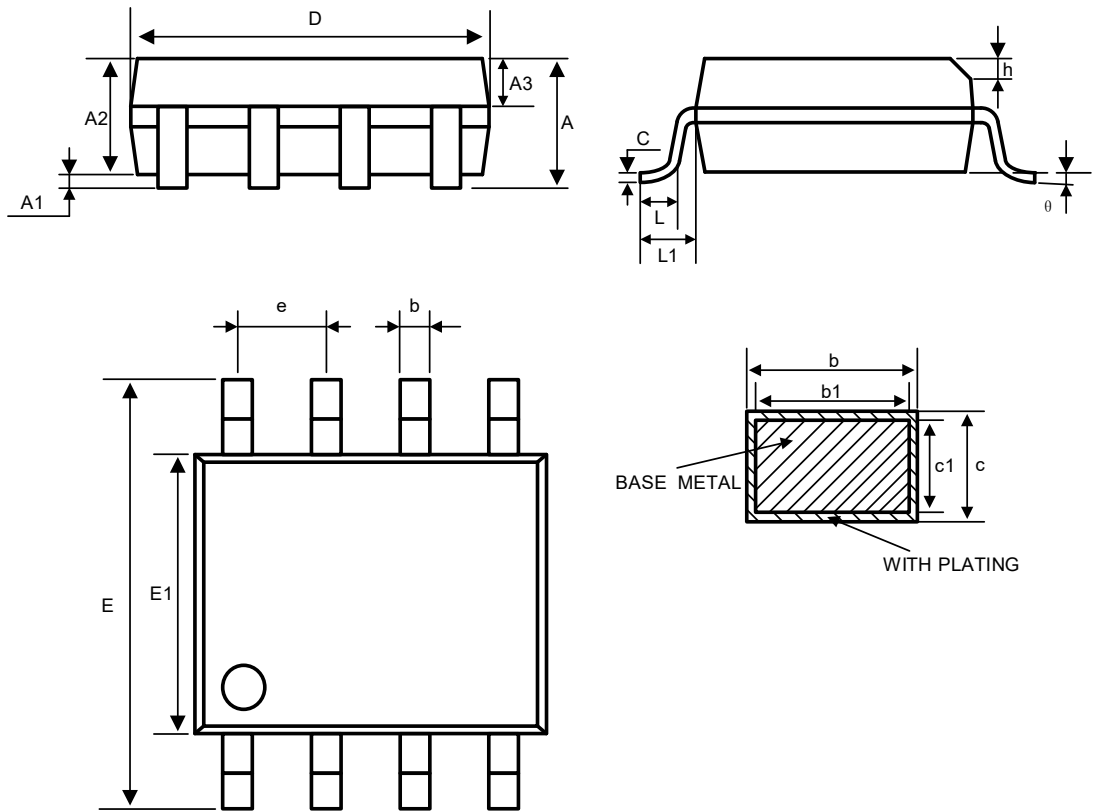

Symbol	Dimensions In Millimeters			Dimensions In Inches		
	Min	Nom	Max	Min	Nom	Max
A	—	—	1.750			0.069
A1	0.100	—	0.225	0.004		0.009
A2	1.300	1.400	1.500	0.051	0.055	0.059
A3	0.600	0.650	0.700	0.024	0.026	0.028
b	0.390	—	0.470	0.015		0.019
b1	0.380	0.410	0.440	0.015	0.016	0.017
c	0.200	—	0.210	0.008		0.008
c1	4.800	4.900	5.000	0.189	0.193	0.197
D	5.800	6.000	6.200	0.228	0.236	0.244
E	5.800	6.000	6.200	0.228	0.236	0.244
E1	3.800	3.900	4.000	0.150	0.154	0.157
e	1.270BSC			0.050BSC		
h	0.250	—	0.500	0.010		0.020
L	0.500	—	0.800	0.020		0.031
L1	1.050REF			0.041REF		
θ	0°	—	8°	0°	—	8°

10 Package Outline Dimension(Continued)

TSSOP8

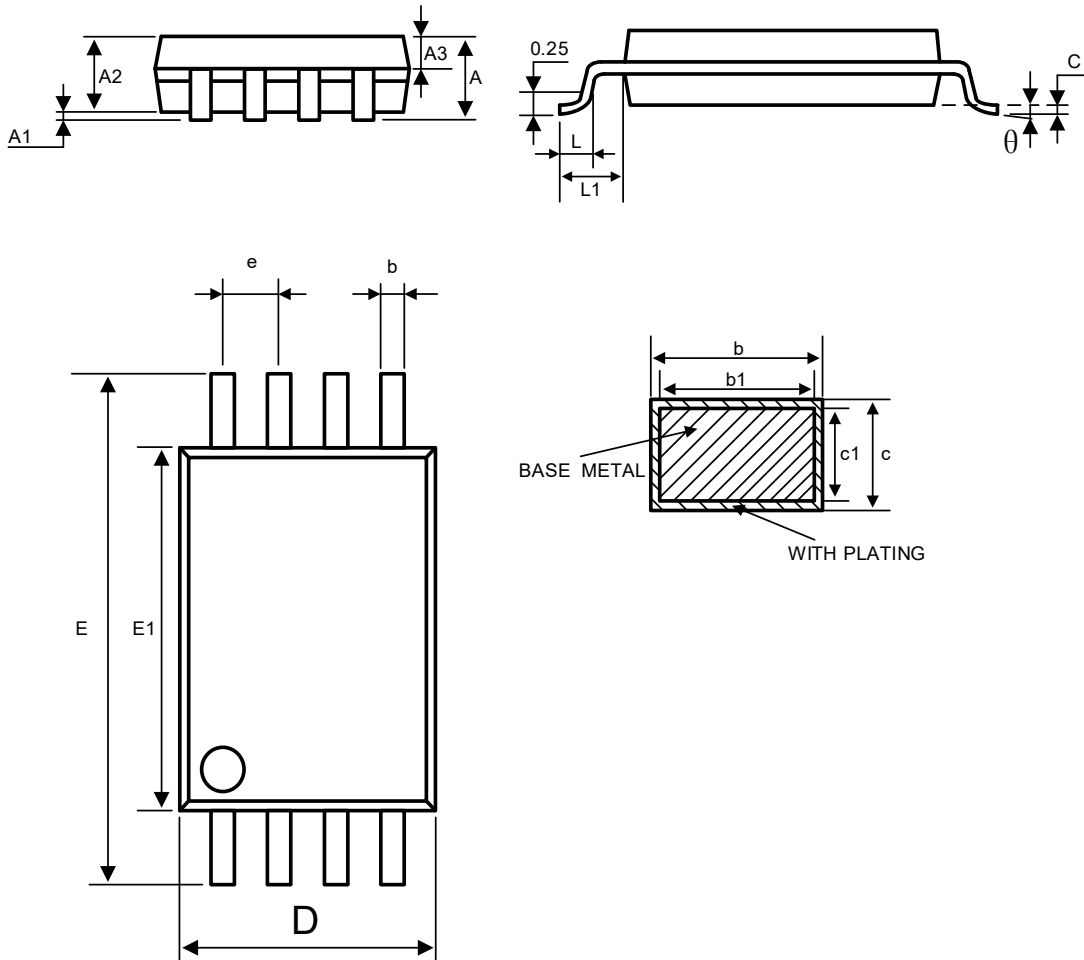

Symbol	Dimensions In Millimeters			Dimensions In Inches		
	Min	Nom	Max	Min	Nom	Max
A	—	—	1.200	—	—	0.047
A1	0.050	—	0.150	0.002	—	0.06
A2	0.900	1.000	1.050	0.035	0.039	0.041
A3	0.390	0.440	0.490	0.015	0.017	0.019
b	0.200	—	0.280	0.008	—	0.011
b1	0.190	0.220	0.250	0.007	0.009	0.010
c	0.130	—	0.170	0.005	—	0.007
c1	0.120	0.130	0.140	0.005	0.005	0.005
D	2.900	3.000	3.100	0.114	0.118	0.122
E1	4.300	4.400	4.500	0.169	0.173	0.177
E	6.200	6.400	6.600	0.244	0.252	0.260
e	0.650BSC			0.026BSC		
L	0.450	—	0.750	0.018	—	0.030
L1	1.000REF			0.039REF		
θ	0°	—	8°	0°	—	8°

10 Package Outline Dimension(Continued)

MSOP8

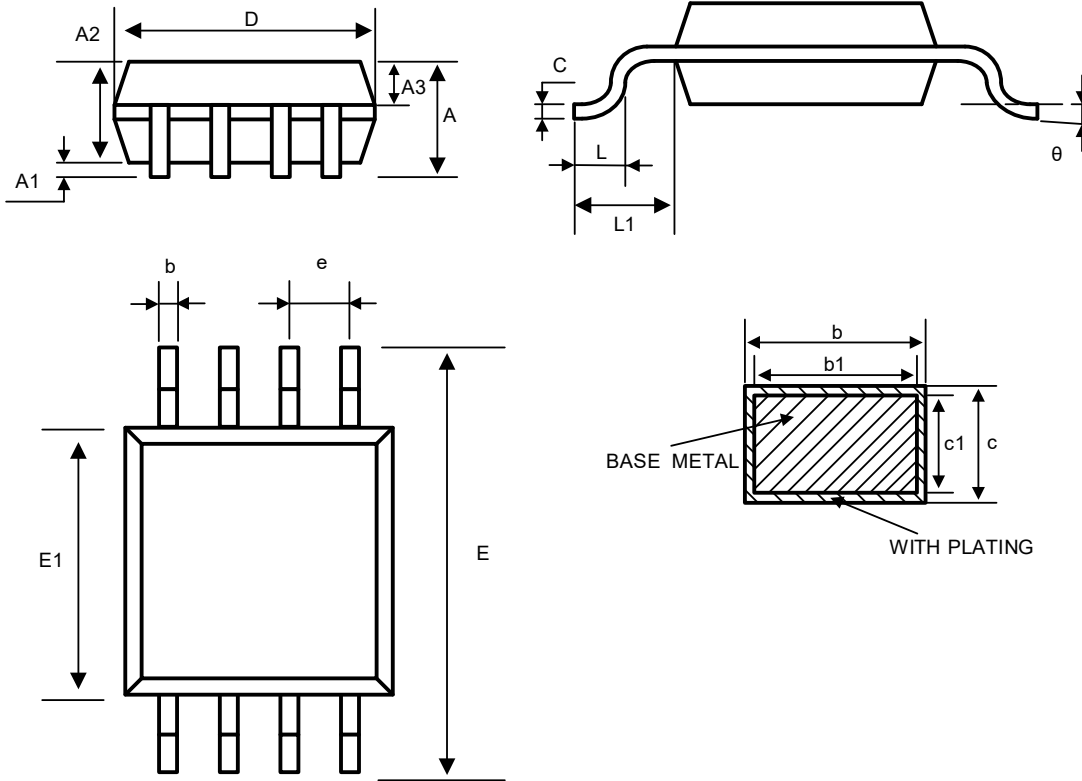

Symbol	Dimensions In Millimeters			Dimensions In Inches		
	Min	Nom	Max	Min	Nom	Max
A	—	—	1.100	—	—	0.043
A1	0.050	—	0.150	0.002	—	0.006
A2	0.750	0.850	0.950	0.030	0.033	0.037
A3	0.300	0.350	0.400	0.012	0.014	0.016
b	0.280	—	0.360	0.011	—	0.014
b1	0.270	0.300	0.330	0.011	0.012	0.013
c	0.150	—	0.190	0.006	—	0.007
c1	0.140	0.150	0.160	0.006	0.006	0.006
D	2.900	3.000	3.100	0.114	0.118	0.122
E	4.700	4.900	5.100	0.185	0.193	0.201
E1	2.900	3.000	3.100	0.114	0.118	0.122
e	0.650BSC			0.026BSC		
L	0.400	—	0.700	0.016	—	0.028
L1	0.950REF			0.037REF		
θ	0°	—	8°	0°	—	8°

10 Package Outline Dimension(Continued)

SOP14

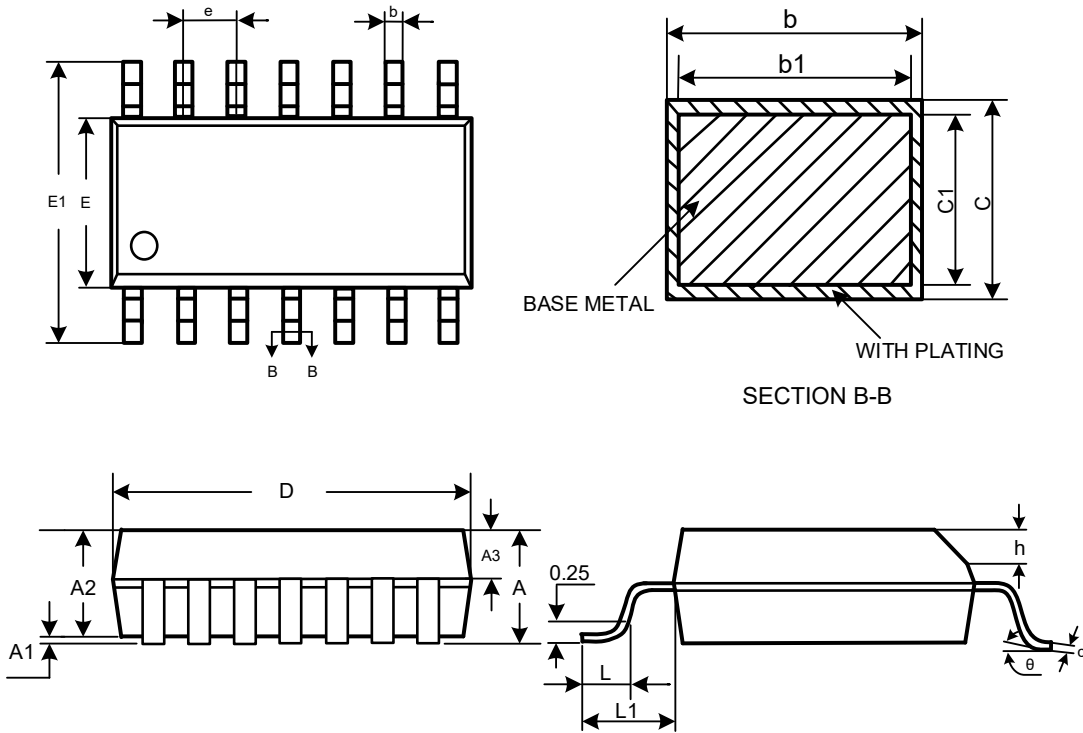

Symbol	Dimensions In Millimeters			Dimensions In Inches		
	Min	Nom	Max	Min	Nom	Max
A	—	—	1.750	—	—	0.069
A1	0.100	—	0.225	0.004	—	0.009
A2	1.300	1.400	1.500	0.051	0.055	0.059
A3	0.600	0.650	0.700	0.024	0.026	0.028
b	0.390	—	0.470	0.015	—	0.019
b1	0.380	0.410	0.440	0.015	0.016	0.017
c	0.200	—	0.240	0.008	—	0.009
c1	0.190	0.200	0.210	0.007	0.008	0.008
D	8.550	8.650	8.750	0.337	0.341	0.344
E1	5.800	6.000	6.200	0.228	0.236	0.244
E	3.800	3.900	4.000	0.150	0.154	0.157
e	1.270BSC			0.05BSC		
h	0.250	—	0.500	0.010	—	0.020
L	0.500	—	0.800	0.020	—	0.031
L1	1.050REF			0.041REF		
θ	0°	—	8°	0°	—	8°

10 Package Outline Dimension(Continued)

TSSOP14

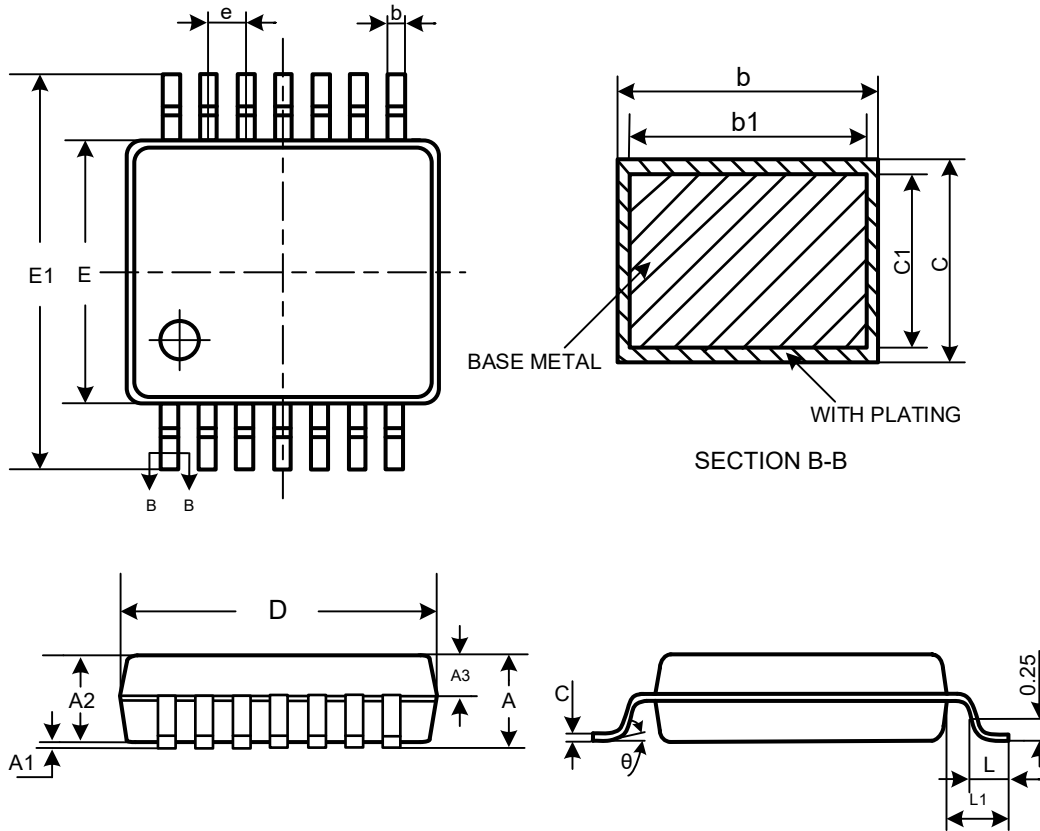

Symbol	Dimensions In Millimeters			Dimensions In Inches		
	Min	Nom	Max	Min	Nom	Max
A	—	—	1.200	—	—	0.047
A1	0.050	—	0.150	0.002	—	0.006
A2	0.900	1.000	1.050	0.035	0.039	0.041
A3	0.390	0.440	0.490	0.015	0.017	0.019
b	0.200	—	0.280	0.008	—	0.011
b1	0.190	0.220	0.250	0.007	0.009	0.010
c	0.130	—	0.170	0.005	—	0.007
c1	0.120	0.130	0.140	0.005	0.005	0.006
D	4.900	5.000	5.100	0.193	0.197	0.201
E	4.300	4.400	4.500	0.169	0.173	0.177
E1	6.200	6.400	6.600	0.244	0.252	0.260
e	0.650BSC			0.026BSC		
L	0.450	0.600	0.750	0.018	0.024	0.030
L1	1.000BCS			0.039BSC		
θ	0°	—	8°	0°	—	8°

11 Tape and Reel Information

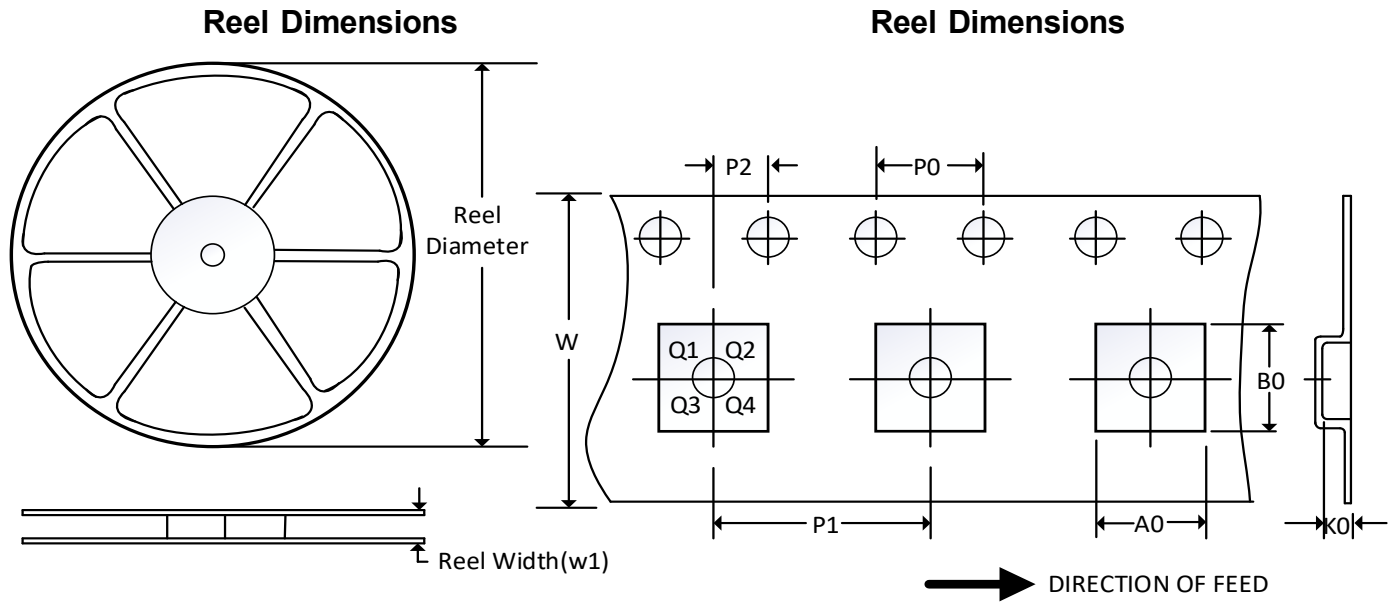

NOTE: The picture is only for reference. Please make the object as the standard.

Key Parameter List of Tape and Reel

Package Type	Reel Diameter	Reel Width (mm)	A0 (mm)	B0 (mm)	K0 (mm)	P0 (mm)	P1 (mm)	P2 (mm)	W (mm)	Pin1 Quadrant
SOT23-5	7"	9.5	3.20	3.20	1.40	4.0	4.0	2.0	8.0	Q3
SC70-5	7"	9.5	2.25	2.55	1.20	4.0	4.0	2.0	8.0	Q3
MSOP8	13"	12.4	5.20	3.30	1.50	4.0	8.0	2.0	12.0	Q1
TSSOP14	13"	12.4	6.95	5.60	1.20	4.0	8.0	2.0	12.0	Q1
SOP8	13"	12.4	6.40	5.40	2.10	4.0	8.0	2.0	12.0	Q1
SOP14	13"	16.4	6.60	9.30	2.10	4.0	8.0	2.0	16.0	Q1
TSSOP8	13"	12.4	6.90	3.45	1.65	4.0	8.0	2.0	12.0	Q1

NOTE:

1. All dimensions are nominal.
2. Plastic or metal protrusions of 0.15mm maximum per side are not included.

Legal Disclaimer

The information given in this document shall in no event be regarded as a guarantee of conditions or characteristics. With respect to any examples or hints given herein, any typical values stated herein and/or any information regarding the application of the device, Oriental Semiconductor hereby disclaims any and all warranties and liabilities of any kind, including without limitation, warranties of non-infringement of intellectual property rights of any third party.

For further information on technology, delivery terms and conditions and prices, please contact the Oriental Semiconductor sales representatives (www.orientalsemi.com).

© Oriental Semiconductor Co.,Ltd. All Rights Reserved 