

100V,100mA,4.5uA,High Voltage,Low-Dropout Voltage Regulator

Features

- Low quiescent current: 4.5uA
- Wide input voltage range: 4V to 100V
- High output current: 100mA
- Fixed output voltages: 3.3V and 5.0V
- Output voltage tolerance: $\pm 1\%/\pm 2\%$
- Current limit protection
- Thermal shutdown protection
- Available packages: SOT89-3

Applications

- Battery-powered equipment
- Smoke detector and sensor
- Micro controller applications
- Home appliance

Description

OSU2AXXA/B is a high-voltage low-power LDO with an input voltage up to 100V, a static current of 4.5uA ($V_{IN}=12V$), $\pm 1\%/\pm 2\%$ high output voltage accuracy and a maximum output current of 100mA. OSU2AXXA/B has a fast response to input voltage transients and load current transients, ensuring no overshoot voltage during startup and short-circuit recovery.

OSU2AXXA/B has current limiting protection and over-temperature protection functions. OSU2AXXA/B includes two fixed output voltages: 3.3V and 5.0V.

Device Information

PART NUMBER	PACKAGE	BODY SIZE(NOM)
OSU2AXXA/BTS-C	SOT89-3	4.5mm*4.2mm

Typical Application

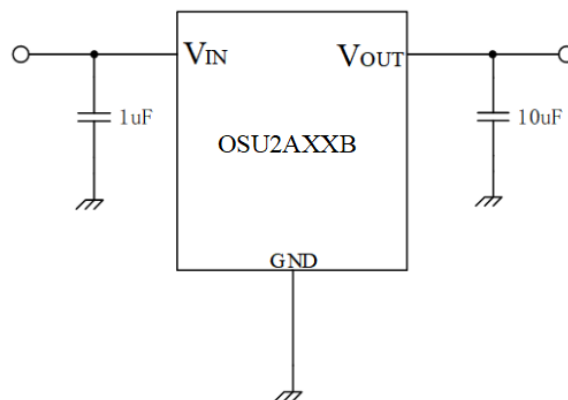

100V, Low-Dropout Voltage Regulator

Pin Configuration and Functions

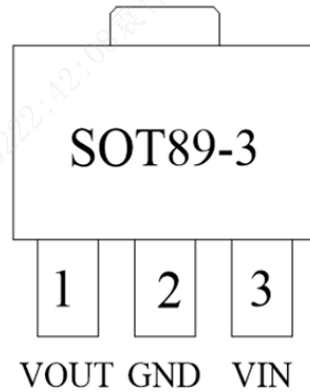

Pin Functions

Name	SOT89-3	Description
	OSU2AXXA/BTS-C	
VOUT	1	Output pin
GND	2	Ground pin
VIN	3	Input pin

Absolute Maximum Ratings

Parameter	Description	Min	Max	Unit
Input voltage	VIN to GND	-0.3	115	V
	VOUT to GND	-0.3	7	V
	VIN to VOUT	-0.3	110	V
Current	Peak output current	Internally limited		
Temperature	Operating temperature range	-40	125	°C
	Storage temperature	-40	150	°C
Thermal resistance (junction to ambient)	SOT89-3	130		°C/W
Power dissipation	SOT89-3	900		mW

Note:

exceeding the range specified by the rated parameters will cause damage to the chip, and the working state of the chip beyond the range of rated parameters cannot be guaranteed. Exposure outside the rated parameter range will affect the reliability of the chip.

ESD Ratings

Parameter	Description	Range	Unit
V _{ESD}	Human body model (HBM)	4	KV

Note:

JEDEC document JEP155 states that 500-V HBM allows safe manufacturing with a standard ESD control process.

Electrical Characteristics

(At $T_A=25^{\circ}\text{C}$, $C_{IN}=1\mu\text{F}$, $V_{IN}=V_{OUTNOM}+1\text{V}$, $C_{OUT}=10\mu\text{F}$, unless otherwise noted)

Symbol	Parameter	Test conditions	Min	Typ	Max	Unit
V_{IN}	Operating input voltage		4	—	100	V
I_{GND}	Quiescent current	$V_{IN}=12\text{V}$, No load	—	4.5	—	μA
V_{OUT}	Output voltage	$V_{IN}=12\text{V}$, $I_{OUT}=10\text{mA}$	—	3.3	—	V
I_{OUT_MAX}	Output current	$V_{IN}=V_{OUTNOM}+1\text{V}$	100	—	—	mA
V_{DROP}	Dropout voltage ⁽¹⁾	$I_{OUT}=10\text{mA}$, $V_{IN}=V_{OUTNOM}-0.1\text{V}$	—	120	—	mV
		$I_{OUT}=100\text{mA}$, $V_{IN}=V_{OUTNOM}-0.1\text{V}$	—	830	—	
$\Delta V_{OUT}/\Delta I_{OUT}$ T	Load regulation	$V_{IN}=7\text{V}$, $1\text{mA}\leq I_{OUT}\leq 100\text{mA}$	—	0.1	—	mV/mA
$\Delta V_{OUT}/\Delta V_{IN}$	Line regulation	$I_{OUT}=1\text{mA}$, $6\text{V}\leq V_{IN}\leq 1000\text{V}$	—	0.1	—	mV/V
I_{LIMIT}	Current limit		—	240	—	mA
I_{SHORT}	Short current	$V_{IN}=12\text{V}$	—	80	—	mA
T_{SHDN}	Thermal shutdown temperature	Shutdown, temperature increasing	—	145	—	$^{\circ}\text{C}$
		Reset, temperature decreasing	—	120	—	

Note:

(1) Dropout Voltage is the voltage difference between the input and the output at which the output voltage drops 2% below its nominal value.

Detailed Description

Overview

OSU2AXXA/B is a high-voltage low-power LDO with an input voltage up to 100V, a static current of 4.5 μ A ($V_{IN}=12V$), $\pm 2\%$ high output voltage accuracy, and a maximum output current of 100mA. OSU2AXXA/B has a fast response to input voltage transients and load current transients, ensuring no overshoot voltage during startup and short-circuit recovery.

OSU2AXXA/B has short-circuited protection, current limiting protection, and over-temperature protection functions.

OSU2AXXA/B includes two fixed output voltages: 3.3V and 5.0V.

Input Capacitor and Output Capacitor

A 1 μ F ceramic capacitor is recommended to connect between VIN and GND pins to decouple input power supply glitch and noise. The amount of the capacitance may be increased without limit. This input capacitor must be located as close as possible to the device to assure input stability and less noise. For PCB layout, a wide copper trace is required for both VIN and GND. When $V_{IN} \geq 48V$, it is recommended to add R1 ($R1 > 1\Omega$, the resistance shall be adjusted according to the actual application) at the input end.

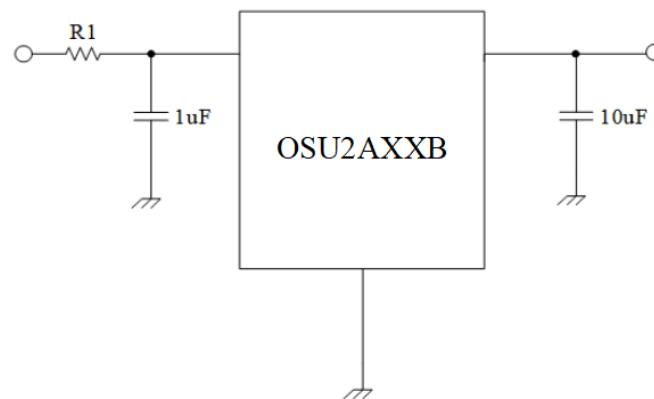

An output capacitor is required for the stability of the LDO. The recommended minimum output capacitance is 10 μ F, ceramic capacitor is recommended, and temperature characteristics are X5R or X7R. Higher capacitance values help to improve load/line transient response. The output capacitance may be increased to keep low undershoot/overshoot. Place output capacitor as close as possible to VOUT and GND pins.

Power Dissipation and Thermal Protection

The OSU2AXXA/B has internal thermal sense and protection circuits. When excessive power dissipation happens on the device, such as short circuit at the output pin or very heavy load current with a large voltage drop across the device, the internal thermal protection circuit will be triggered, and it will shut down the power MOSFET to prevent the LDO from damage. As soon as excessive thermal condition is removed and the temperature of the device drops down, the thermal

protection circuit will lease the control of the power MOSFET, and the LDO device goes to normal operation.

Power dissipation caused by voltage drop across the LDO and by the output current flowing through the device needs to be dissipated out from the chip. The maximum junction temperature is dependent on power dissipation, package, the PCB layout, number of used Cu layers, Cu layers thickness and the ambient temperature.

During normal operation, LDO junction temperature should not exceed 150°C, or else it may result in deterioration of the properties of the chip. Using below equations to calculate the power dissipation and estimate the junction temperature.

The power dissipation can be calculated using Equation (1).

$$P_D = (V_{IN} - V_{OUT}) \times I_{OUT} \quad (1)$$

The junction temperature can be estimated using Equation. $R_{\theta JA_EVM}$ is the junction-to-ambient thermal resistance based on customer's PCB. Verify the application and allow sufficient margins in the thermal design by the Equation (2).

$$T_J = T_A + P_D \times R_{\theta JA_EVM} \quad (2)$$

$R_{\theta JA_EVM}$ is a critical parameter and depends on many factors such as the following:

- Power dissipation
- Air temperature/flow
- PCB area
- Copper heat-sink area
- Number of thermal vias under the package
- Adjacent component placement

典型性能特征

(At $T_A=25^{\circ}\text{C}$, $C_{IN}=1\mu\text{F}$, $V_{IN}=V_{OUTNOM}+1\text{V}$, $C_{OUT}=10\mu\text{F}$, $V_{OUT}=3.3\text{V}$ unless otherwise noted)

Output Voltage vs. Input Voltage

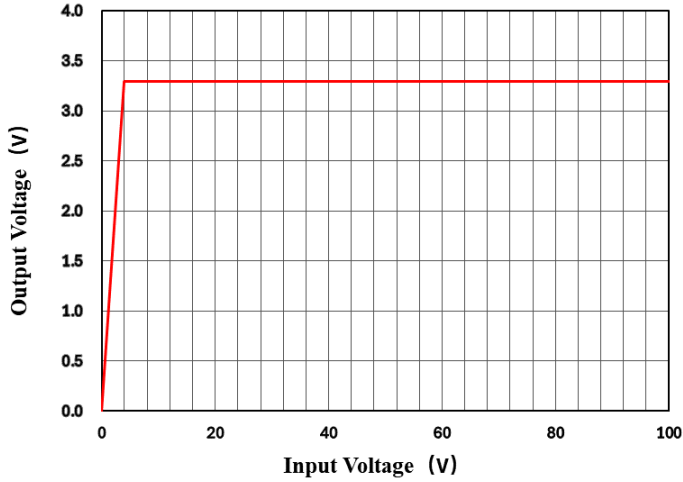

Output Voltage vs. Temperature

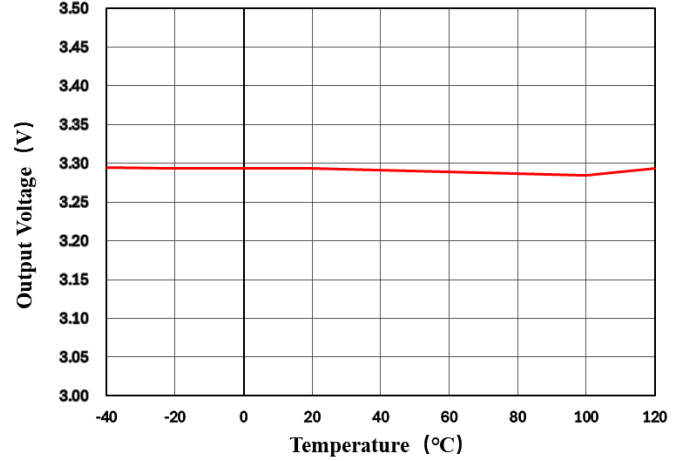

Dropout Voltage vs. Output Current

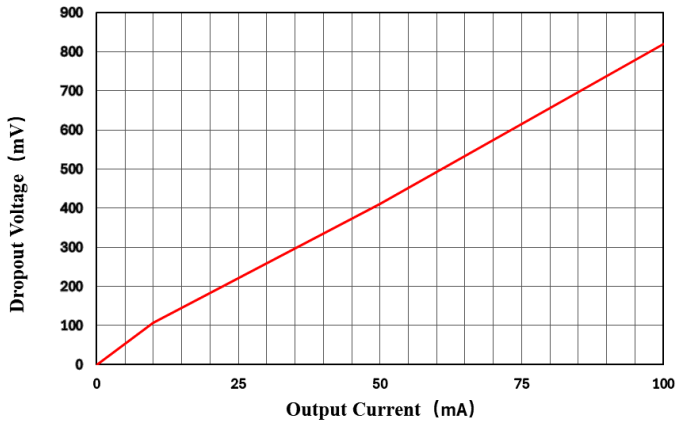

Quiescent Current vs. Temperature

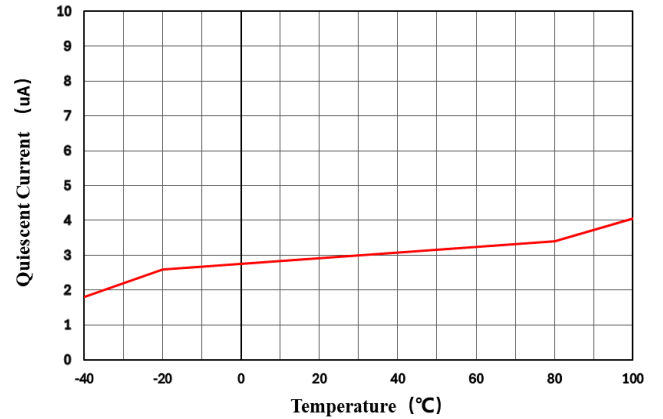

Quiescent Current vs. Input Voltage

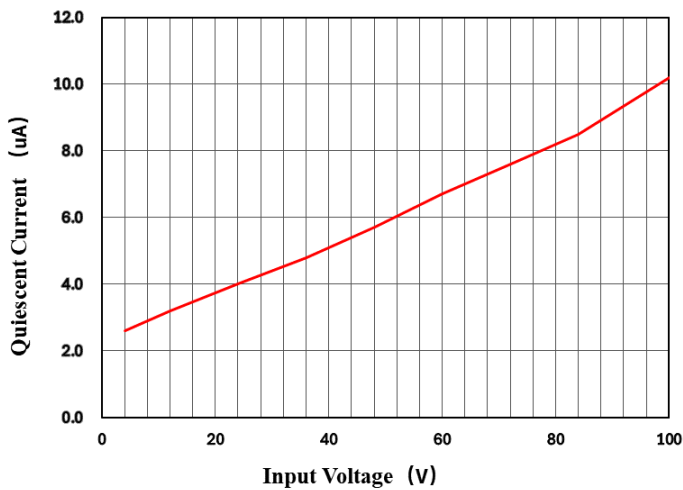

Dropout Voltage vs. Temperature

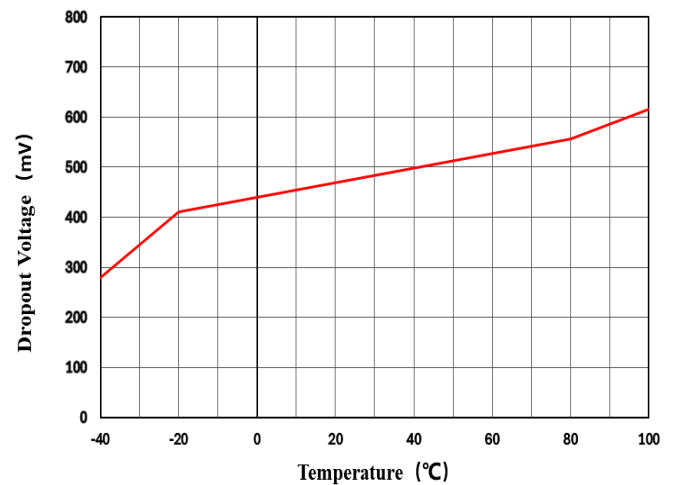

Line Transient Response

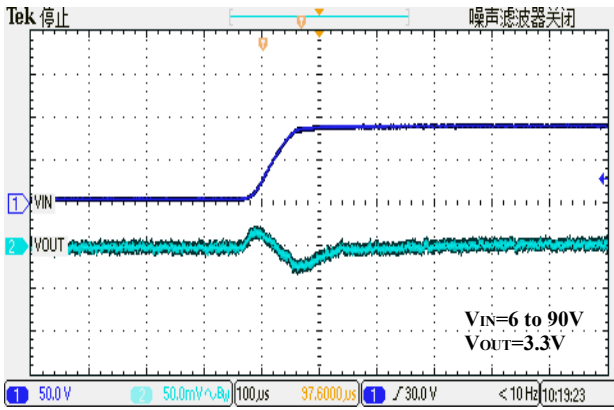

Line Transient Response

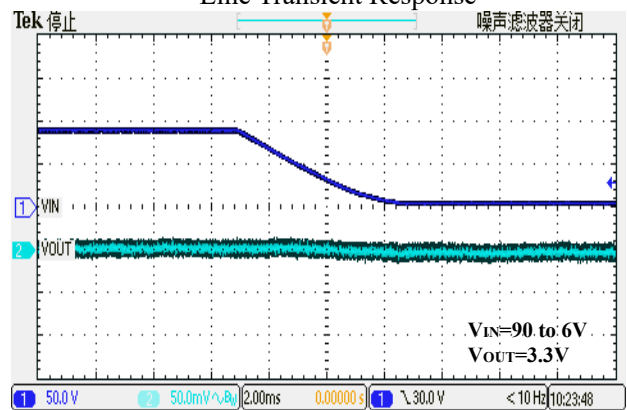

Load Transient Response

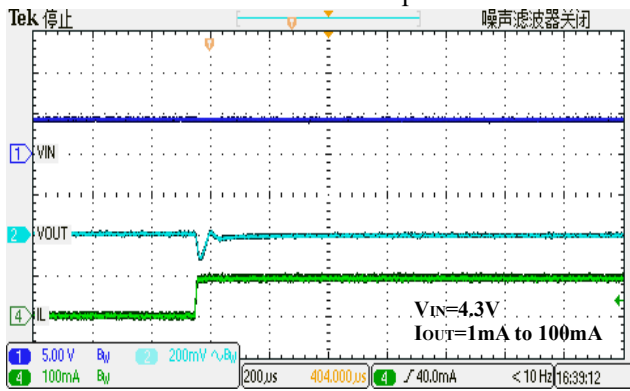

Load Transient Response

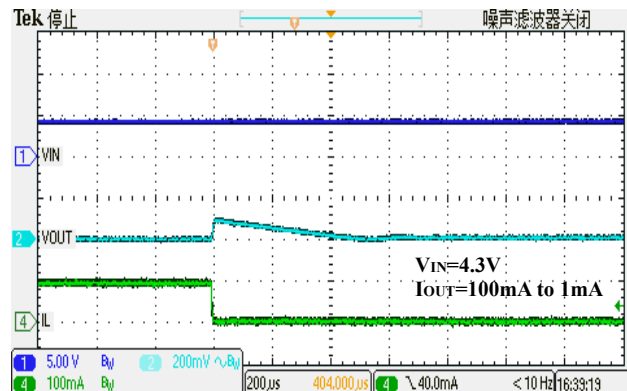

Start Up

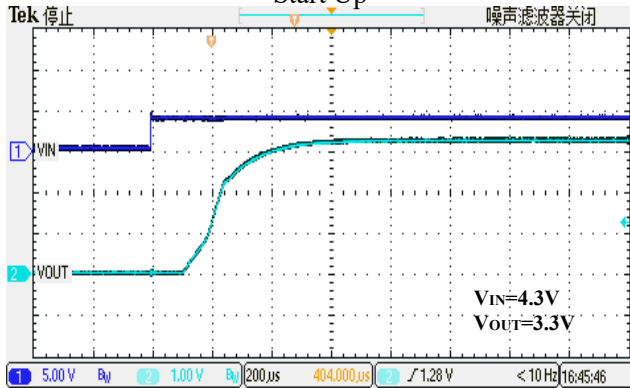

Start Up

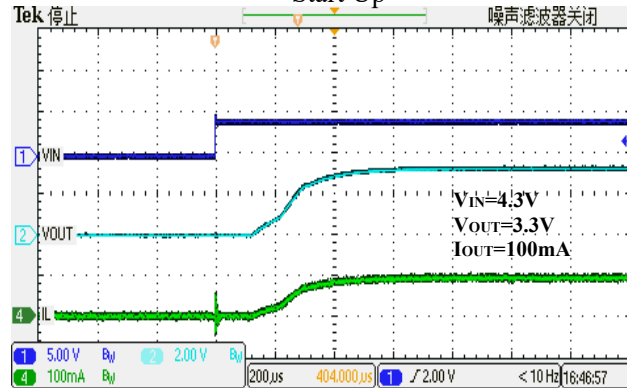

Short Circuit Protection

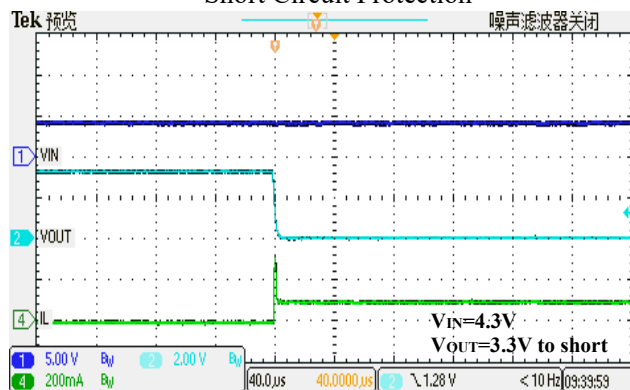

Short Circuit Protection

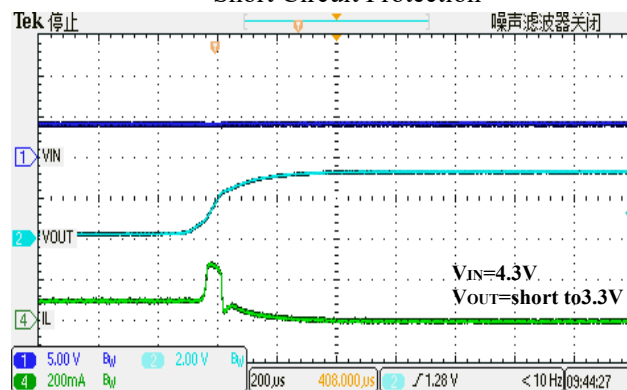

Ordering And Marking Information

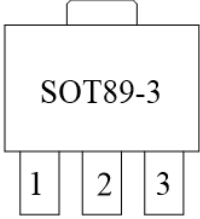
<p align="center">Part Number</p>	<p align="center">Package Outline</p>	
<p><u>OS</u> <u>U2A</u> <u>XXB</u> <u>TS</u> <u>-C</u></p> <p>Pin Definition Package definit Voltage accuracy Product name Company name</p>	<p align="center">Minimum Package</p>	<p align="center">SOT89-3 1000pcs/Reel</p>
	<p align="center">Marking</p>	<p><u>2AXX</u> <u>B</u> B:B(±2%) A(±1%) C(±3%) 2AXX:2A33(3.3V) 2A50(5.0V)</p> <p><u>429</u> <u>X</u> X:Internal Code.Variable. 429:4-2024;29-the 29th week of this year</p>

Package Outline

SOT89-3

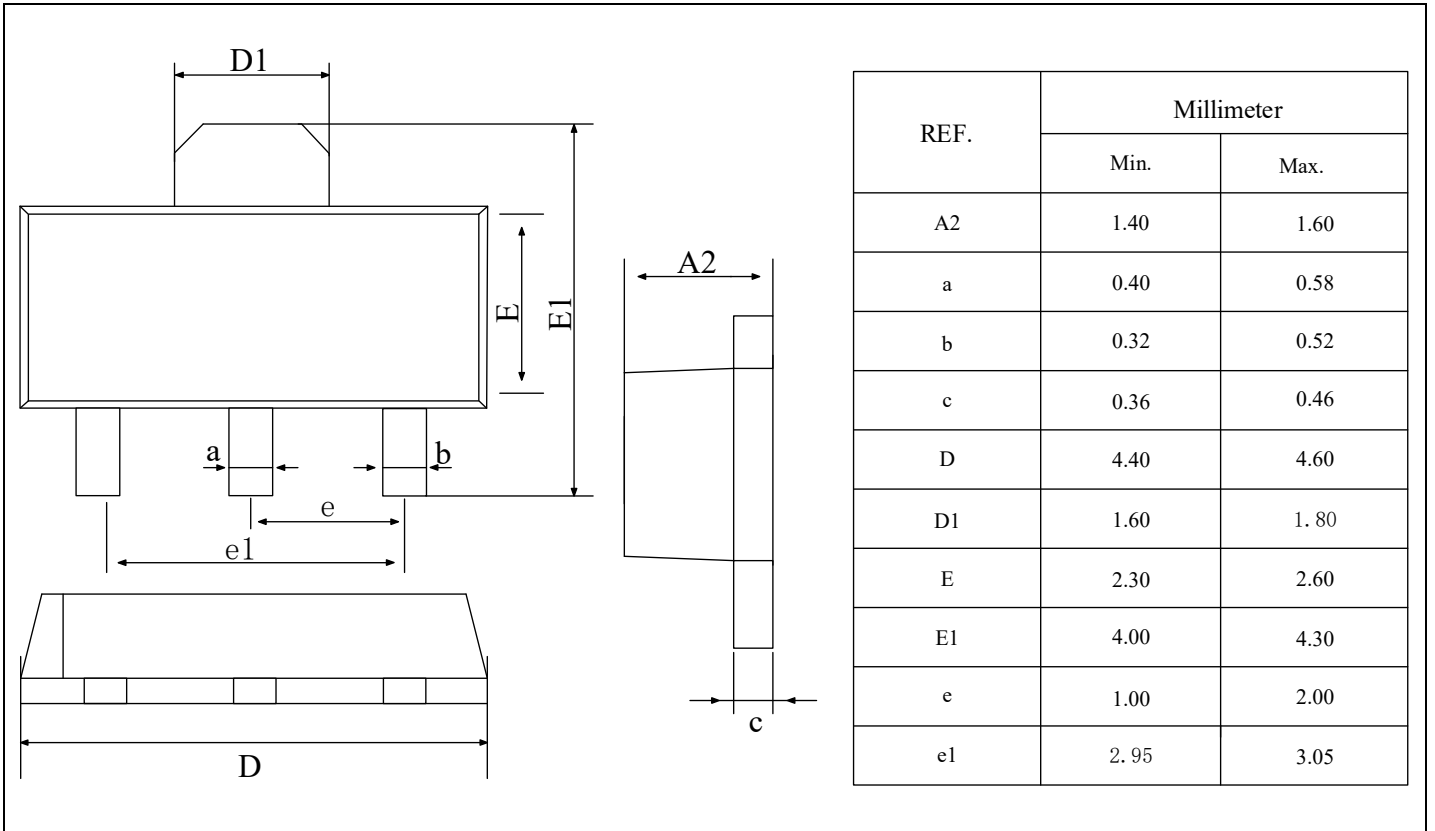

Packing Information

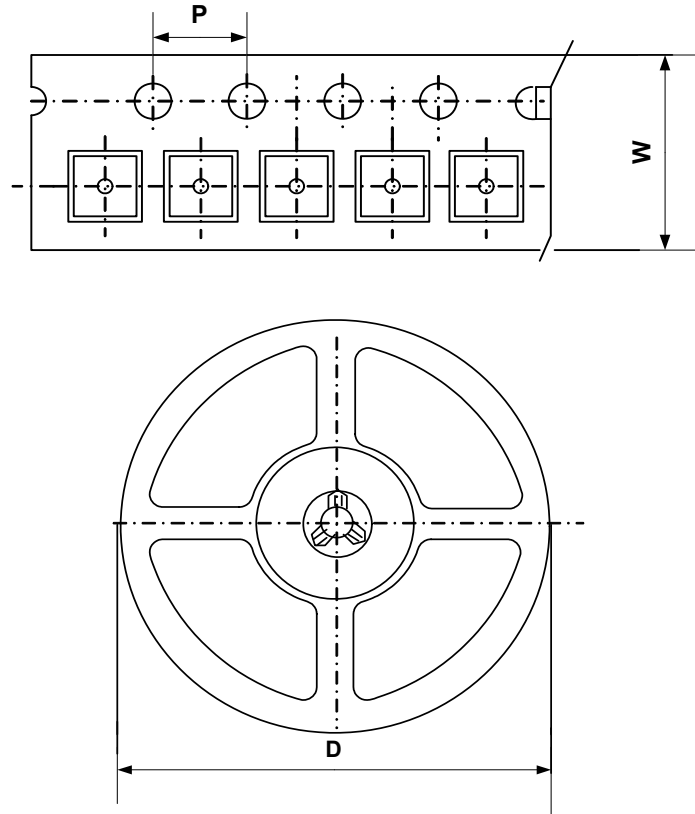

Type	W(mm)	P(mm)	D(mm)	Qty (pcs)
SOT89-3	12.0mm	4.0mm	178.0mm	1000pcs

Legal Disclaimer

The information given in this document shall in no event be regarded as a guarantee of conditions or characteristics. With respect to any examples or hints given herein, any typical values stated herein and/or any information regarding the application of the device, Oriental Semiconductor hereby disclaims any and all warranties and liabilities of any kind, including without limitation, warranties of non-infringement of intellectual property rights of any third party.

For further information on technology, delivery terms and conditions and prices, please contact the Oriental Semiconductor sales representatives (www.orientalsemi.com).

© **Oriental Semiconductor Co.,Ltd. All Rights Reserved** 