

Very High PSRR Low Noise 500mA RF LDO

Features

- Wide input voltage range: 2.0V to 6.0V
- Up to 500mA load current
- Output voltage options available on request
- Very low I_Q: 50uA
- Very High PSRR: 82dB at 1kHz
- Ultra low noise: 45uV_{RMS} at 1.2V output
- Ultra-Fast start-up time: 25us
- Excellent load/line transient response
- Line regulation: 0.03% typical
- Standard fixed output voltage options: 1.2V, 1.5V, 1.6V, 1.8V, 2.5V, 2.8V, 3.0V, and 3.3V,etc
- Ultra low dropout: 250mV at 300mA load@V_{OUT}=2.8V

Applications

- Digital still cameras
- Portable instruments
- MP3/MP4 Player
- Smart phones and cellular phones

Description

The OSU29193 family of low-dropout(LDO), low-power Linear regulators offers very high power supply rejection ratio (PSRR) while maintaining very low 50uA ground current, suitable for RF applications. The family uses an advanced CMOS process and a PMOSFET pass device to achieve fast start-up, very low noise, excellent transient response, and excellent PSRR performance.

The OSU29193 is stable with a 1.0uF ceramic output capacitor, and uses a precision voltage reference and feedback loop to achieve a worst-case accuracy of 2% over all load, line, process, and temperature variations. It is fully specified from T_J = -40°C to +150°C and is offered in a small DFN4 package, which is ideal for small form factor portable equipment such as wireless handsets and PDAs.

Device Information

PART NUMBER	PACKAGE	BODY SIZE(NOM)
OSU29193A/BTG-XX	SOT23-5	2.9mm*2.8mm
OSU29193A/BTN-XX	DFN4	1.0mm*1.0mm

Typical Application

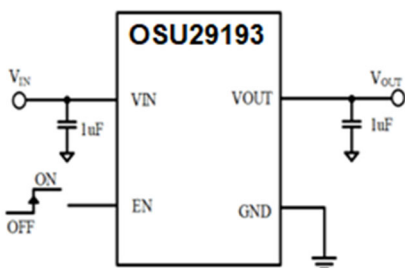

Low Noise 500mA RF LDO

PSRR

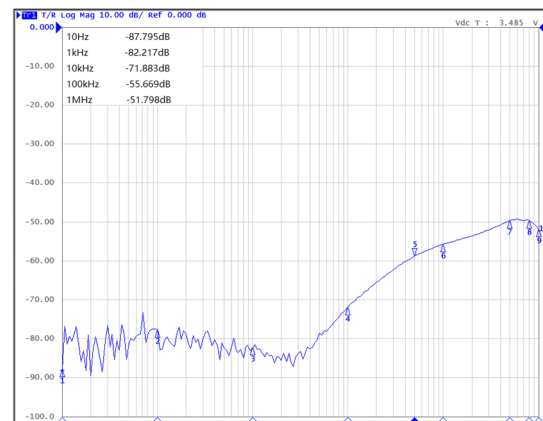

V_{IN}=4.5V, V_{OUT}=3.5V, I_{OUT}=10mA

Pin Configuration and Functions

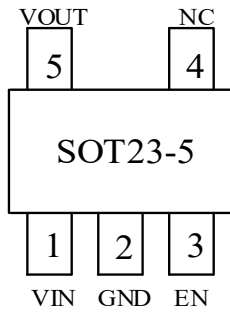

OSU29193A/BTG-XX

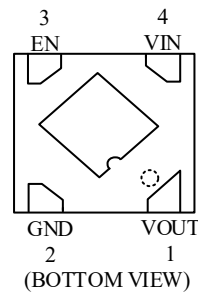
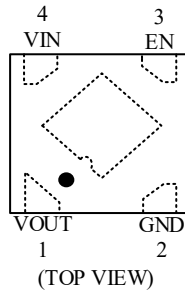

OSU29193A/BTN-XX

Name	SOT23-5	DFN4	Description
	OSU29193A/BTG-XX	OSU29193A/BTN-XX	
VIN	1	4	Input pin
GND	2	2	Ground pin
EN	3	3	Enable pin
NC	4	-	No connection
VOUT	5	1	output Pin

Absolute Maximum Ratings

Parameter	Description	Min	Max	Unit
Input voltage	VIN to GND	-0.3	6.5	V
	Other pin voltage	-0.3	VIN+0.3	V
Current	Maximum load current	500		mA
Temperature	Operating temperature range	-40	150	°C
	Storage temperature	-65	150	°C
θ_{JA}	SOT23-5	200		°C/W
	DFN4	300		
Power Dissipation	SOT23-5	600		mW
	DFN4	400		

Note:

Exceeding the range specified by the rated parameters will cause damage to the chip, and the working state of the chip beyond the range of rated parameters cannot be guaranteed. Exposure outside the rated parameter range will affect the reliability of the chip.

Recommended Operating Conditions

Parameter	Description	Min	Max	Unit
Input voltage	VIN to GND	2	6	V
	Other pin voltage	-0.3	VIN+0.3	V
Current	Maximum load current	0	500	mA
Temperature	Operating temperature range	-40	85	°C
Input capacitor	Effective input ceramic capacitor value	0.47	4.7	uF
Output capacitor	Effective output ceramic capacitor value	0.47	4.7	uF
ESR	Input output capacitor equivalent series resistance	5	100	mΩ

Electrical Characteristics

($V_{IN}=V_{EN}=V_{OUT}+1.0V$, $I_{OUT}=1mA$, $C_{IN}=1\mu F$, $C_{OUT}=1\mu F$, typical values are at $T_A=25^\circ C$ unless otherwise noted)

Parameter	Symbol	Test Conditions	Min	Typ	Max	Unit
Operating input voltage	V_{IN}		2.0	—	6.0	V
Dropout voltage	V_{DROP}	$V_{OUT} = 1.2V, I_{OUT} = 300mA$	—	700	800	mV
		$V_{OUT} = 1.5V, I_{OUT} = 300mA$	—	600	730	
		$V_{OUT} = 1.6V, I_{OUT} = 300mA$	—	500	650	
		$V_{OUT} = 1.8V, I_{OUT} = 300mA$	—	380	520	
		$V_{OUT} = 2.5V, I_{OUT} = 300mA$	—	280	450	
		$V_{OUT} = 2.8V, I_{OUT} = 300mA$	—	250	400	
		$V_{OUT} = 3.0V, I_{OUT} = 300mA$	—	240	390	
		$V_{OUT} = 3.3V, I_{OUT} = 300mA$	—	210	360	
DC supply quiescent current	I_{Q_ON}	Active mode: $V_{EN} = V_{IN}$	—	36	60	μA
DC supply shutdown current	I_{Q_OFF}	$V_{EN} = 0V$	—	0.01	1	μA
Regulated output voltage	V_{OUT}	$I_{OUT} = 1mA, -40^\circ C \leq T_A \leq 85^\circ C$	-2	—	2	%
Output voltage line regulation	R_{eg_LINE}	$V_{IN} = V_{OUT} + 1V$ to 5.5V, $I_{OUT} = 10mA$	—	0.03	0.2	%
Output voltage load regulation	R_{eg_LOAD}	I_{OUT} from 1mA to 300mA	—	0.2	0.7	%
Current limit	I_{LIM}		—	500	—	mA
Power supply rejection ratio	PSRR	$f = 1kHz, C_{OUT} = 1\mu F, I_{OUT} = 20mA$	—	82	—	dB
		$f = 10kHz, C_{OUT} = 1\mu F, I_{OUT} = 30mA$	—	72	—	
Output noise	e_n	10Hz to 100kHz, $C_{OUT} = 1\mu F$, $I_{OUT} = 200mA, V_{OUT} = 2.8V$	—	70	—	μV_{RMS}
		10Hz to 100kHz, $C_{OUT} = 1\mu F$ $I_{OUT} = 200mA, V_{OUT} = 1.2V$,	—	45	—	
Soft-start time	T_{ON}	From enable to power on	—	25	—	μs
EN low threshold	V_{EN_L}		—	—	0.3	V
EN high threshold	V_{EN_H}		1.5	—	—	V
EN pull-down resistance	R_{PD}		0.8	1	1.3	$M\Omega$
Over-temperature shutdown threshold	T_{TSD}		—	155	—	$^\circ C$
Over-temperature shutdown hysteresis	T_{TSR}		—	20	—	$^\circ C$

Functional Block Diagram

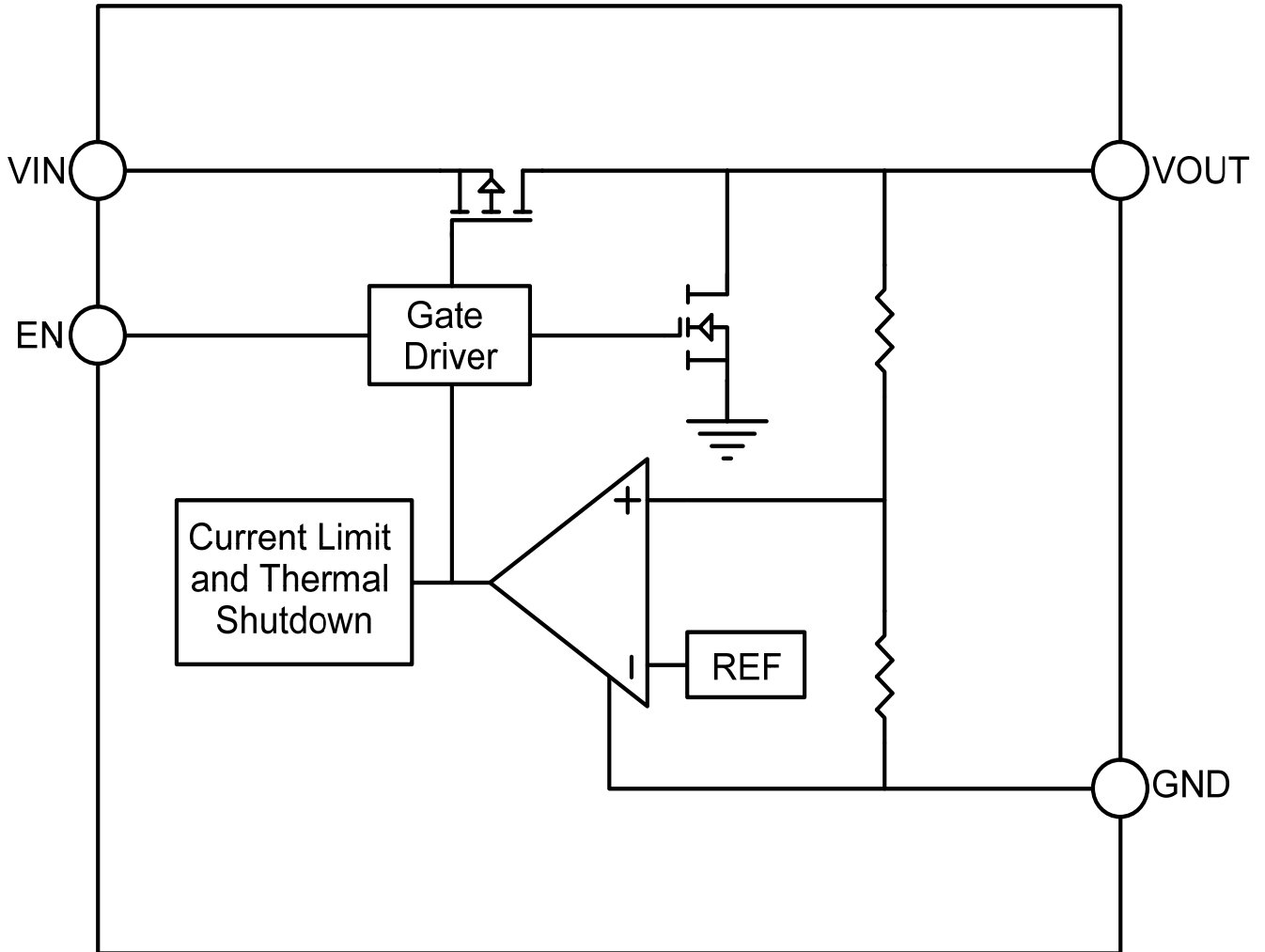

Functional Block Diagram

Typical Characteristics

(OSU29193A/BTG-33, Test Condition: $T_A = 25^\circ\text{C}$, $C_{IN} = 1\mu\text{F}$, $V_{IN} = V_{OUTNOM} + 1\text{V}$, $C_{OUT} = 1\mu\text{F}$ unless otherwise note)

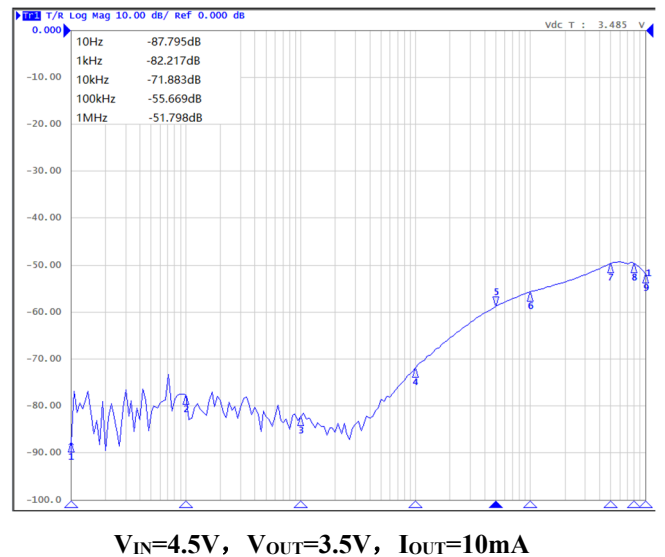
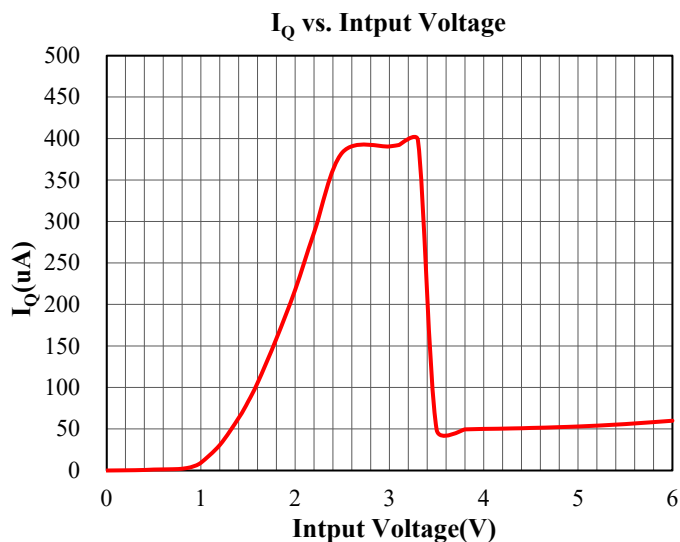
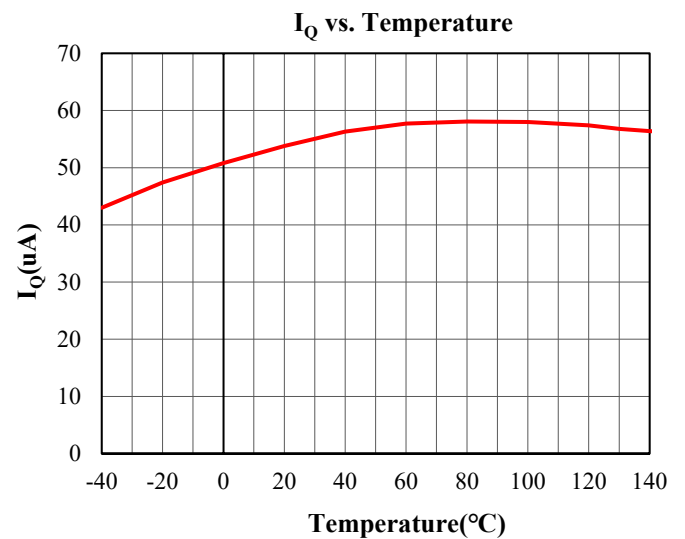
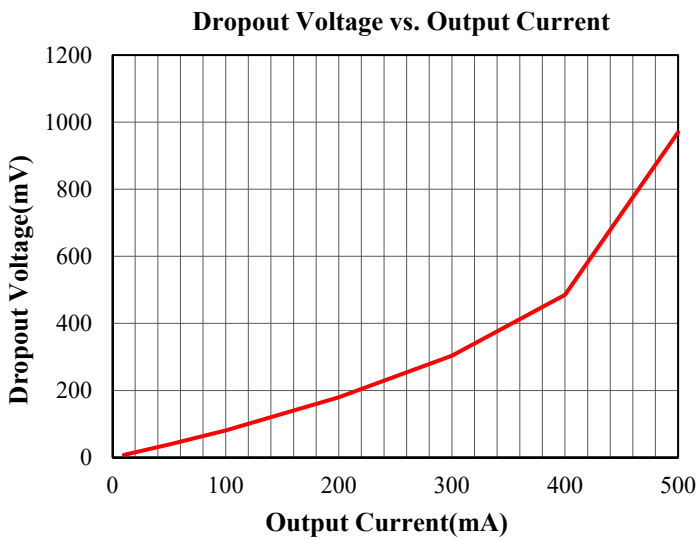
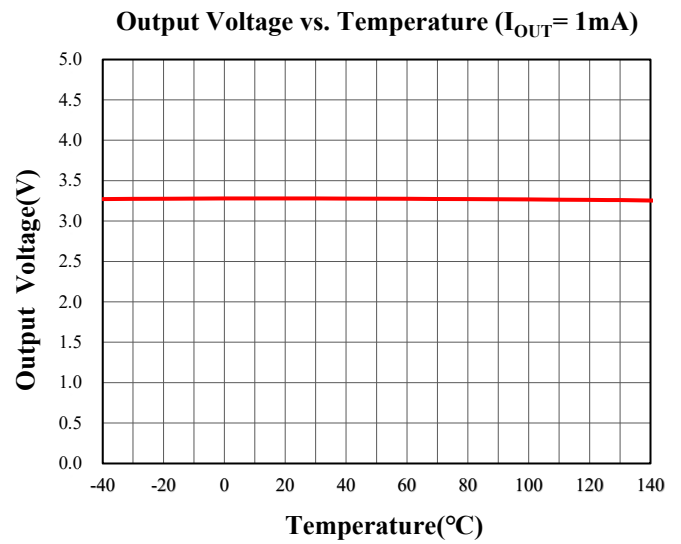
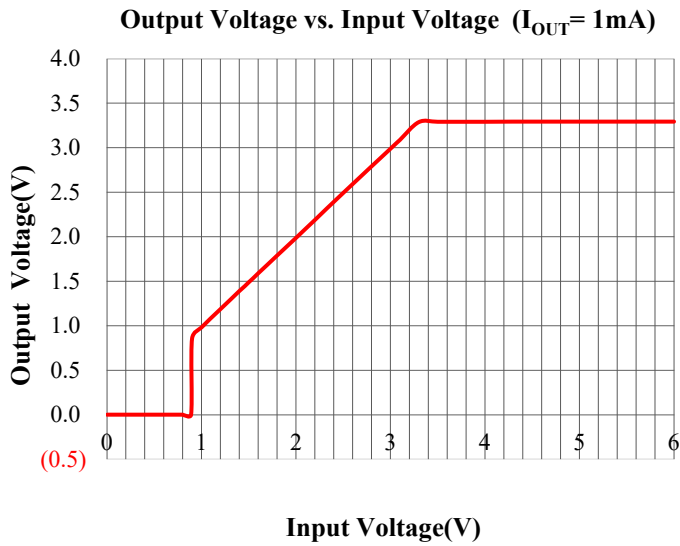

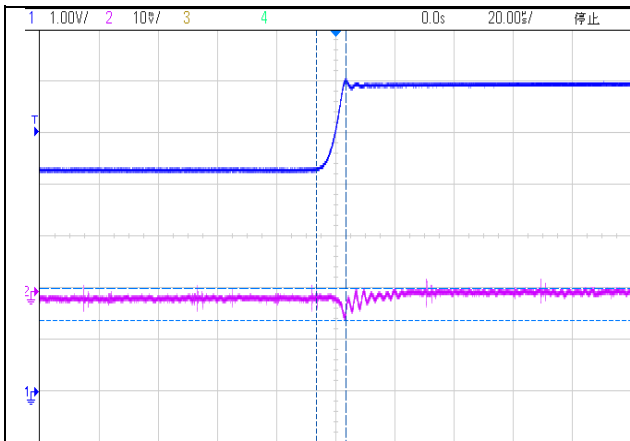

Input Transient(4.3~6V t = 10us 10mA)

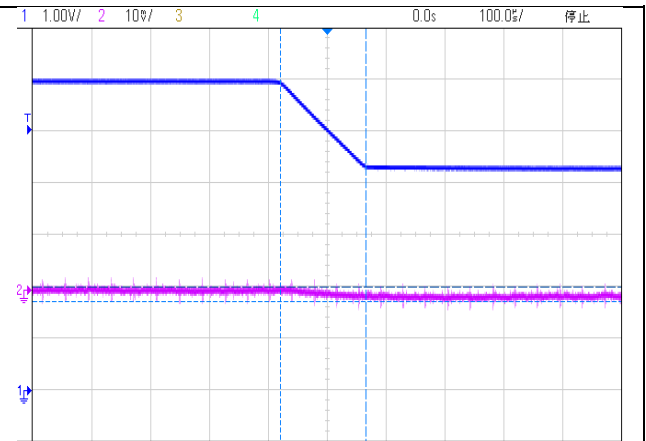

Input Transient(6~4.3V t = 10us 10mA)

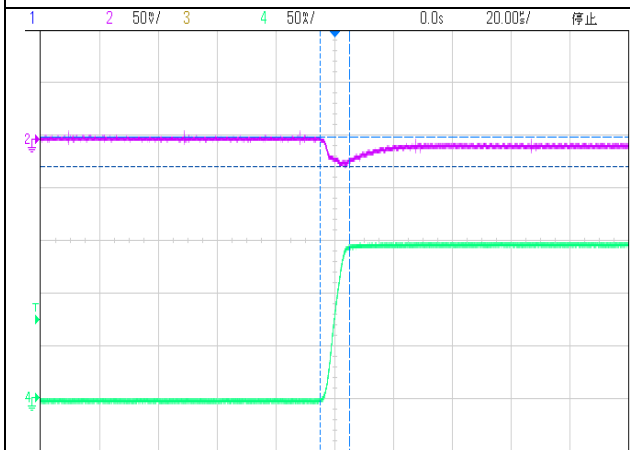

Load Transient(1mA~150mA t = 10us)

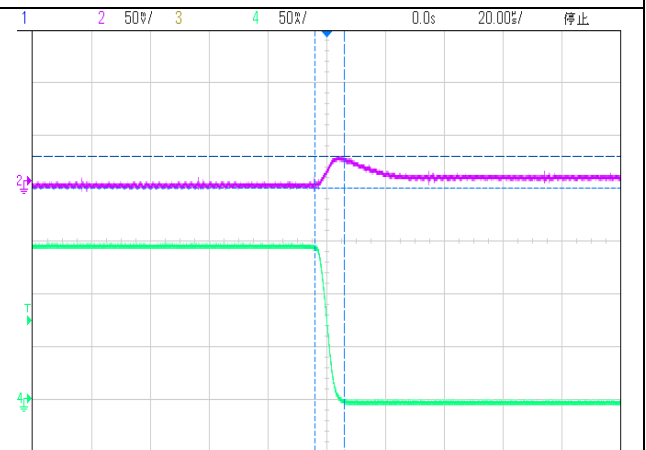

Load Transient(150mA~1mA t = 10us)

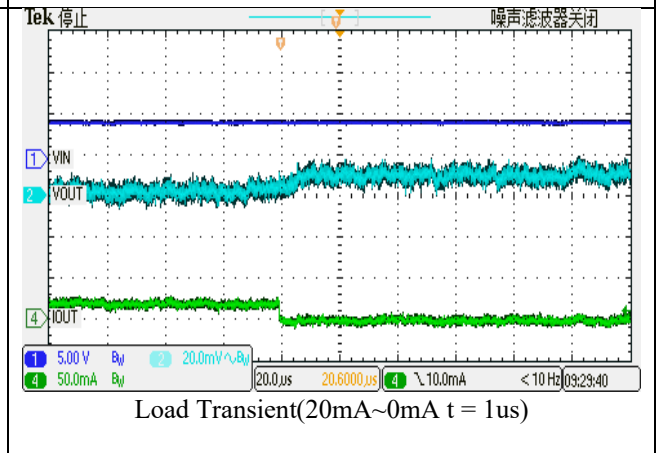
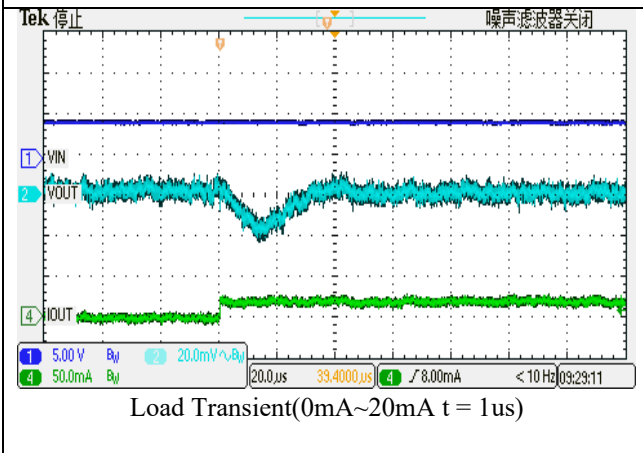
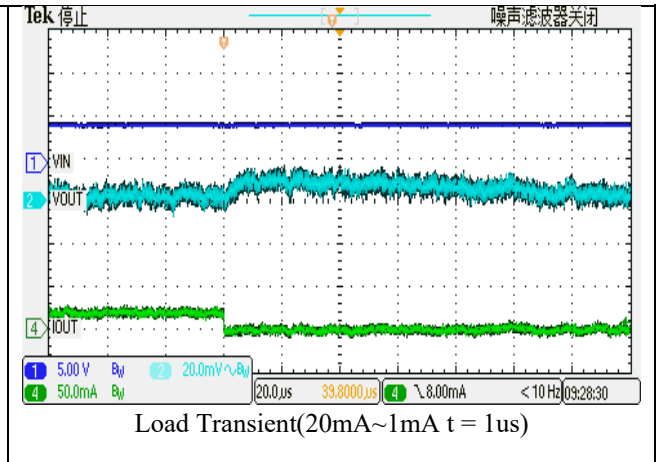
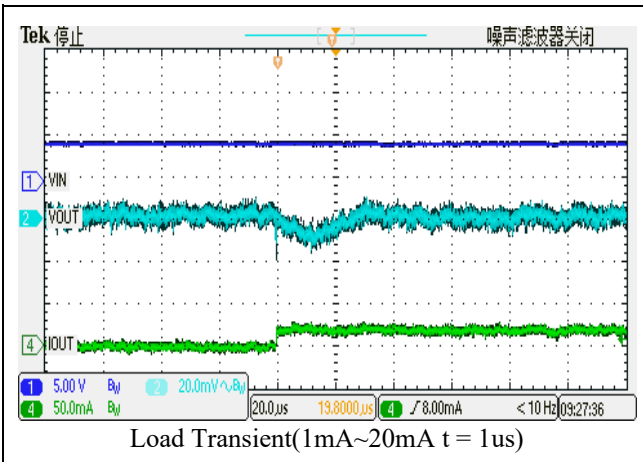

Detailed Description

Overview

The OSU29193-XX series products are 500mA wide input voltage range linear regulators.

These voltage regulators operate from 2V to 6V DC input voltage with supporting 6V transient input voltage and consume 50uA quiescent current at no load. The OSU29193-XX series products also provide enable control and Power-Good feature, which is very suitable for the

applications needing sequence configuration. Other protection features include the VIN input under-voltage lockout, over current protection, output hard short protection and thermal shutdown protection.

The OSU29193-XX series products are available in fixed voltage versions of 1.2V, 1.5V, 1.6V, 1.8V, 2.5V, 2.8V, 3.0V and 3.3V.

Input Capacitor

A 1uF ceramic capacitor is recommended to connect between VIN and GND pins to decouple input power supply glitch and noise. The amount of the capacitance may be increased without limit. This input capacitor must be located as close as possible to the device to assure input stability and less noise. For PCB layout, a wide copper trace is required for both VIN and GND.

Output Capacitor

An output capacitor is required for the stability of the LDO. The recommended output capacitance is from 1uF to 2.2uF, Equivalent Series Resistance (ESR) is from 5mΩ to 100mΩ, and temperature characteristics are X7R or X5R. Higher capacitance values help to improve load/line transient response. The output capacitance may be increased to keep low undershoot/overshoot. Place output capacitor as close as possible to OUT and GND pins.

ON/OFF Input Operation

The OSU29193-XX is turned on by setting the EN pin high, and is turned off by pulling it low. If this feature is not used, the EN pin should be tied to IN pin to keep the regulator output on at all time.

High PSRR and Low Noise

RF circuits such as LNA (low-noise amplifier), up/down-converter, mixer, PLL, VCO, and IF stage, require low noise and high PSRR LDOs. The temperature-compensated crystal oscillator circuit requires very high PSRR at RF power amplifier burst frequency. For instance, minimum 65dB PSRR at 217Hz is recommended for the GSM handsets. The OSU29193-XX, with PSRR of 75dB at 1kHz, is suitable for most of these applications that require high PSRR and low noise.

Ultra-Fast Start-up

After enabled, the OSU29193-XX is able to provide full power in as little as tens of microseconds, typically 25us. This feature will help load circuitry move in and out of standby mode in real time, eventually extend battery life for mobile phones and other portable devices.

Fast Transient Response

Fast transient response LDOs can also extend battery life. To meet this load requirement, the LDO must react very quickly without a large voltage drop or overshoot a requirement that cannot be met with conventional, general-purpose LDOs.

The OSU29193-XX's fast transient response from 0 to 150mA provides stable voltage supply for fast DSP and GSM chipset with fast changing load.

Low Quiescent Current

The OSU29193-XX, consuming only around 50uA for all input range and output loading, provides great power saving in portable and low power applications.

Current Limit Protection

When output current at the OUT pin is higher than current limit threshold or the OUT pin is short-circuit to GND, the current limit protection will be triggered and clamp the output current to approximately 500mA to prevent over-current and to protect the regulator from damage due to overheating.

Thermal Shutdown Protection

Thermal protection disables the output when the junction temperature rises to approximately +155°C, allowing the device to cool down. When the junction temperature reduces to approximately +130°C the output circuitry is enabled again. Depending on power dissipation, thermal resistance, and ambient temperature, the thermal protection circuit may cycle on and off. This cycling limits the heat dissipation of the regulator, protecting it from damage due to overheating.

Ordering And Marking Information

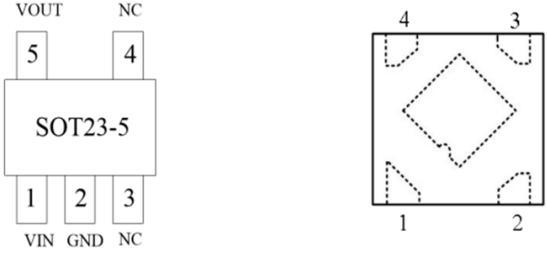
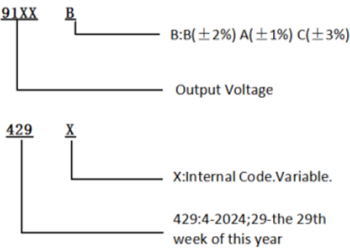
<p>Part Number</p>	<p>Package Outline</p>		
<p>OS U29193 B XX XX</p> <ul style="list-style-type: none"> — Output Voltage — Package definition — Voltage accuracy — Product name — Company name 		<p>Minimum Package</p>	<p>SOT23-5 3000pcs/Reel</p>
	<p>Marking</p>	 <p style="text-align: center;">Output voltage</p> <p style="text-align: center;">XX XX</p> <p style="text-align: center;">Year and week number 4=2024, 5=2025... A=week 1 a=week 27...</p>	

Package Dimension

SOT23-5

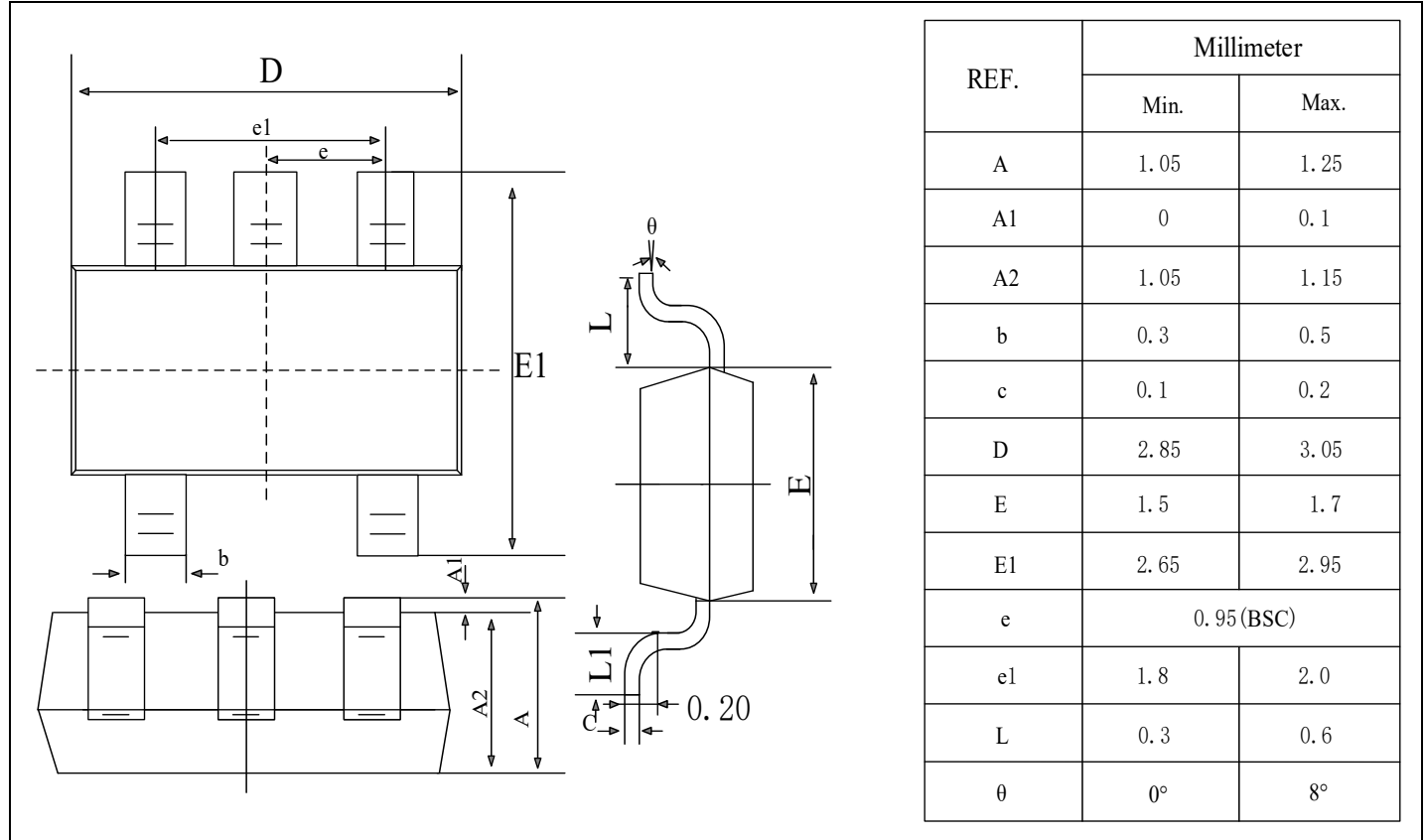

DFN4

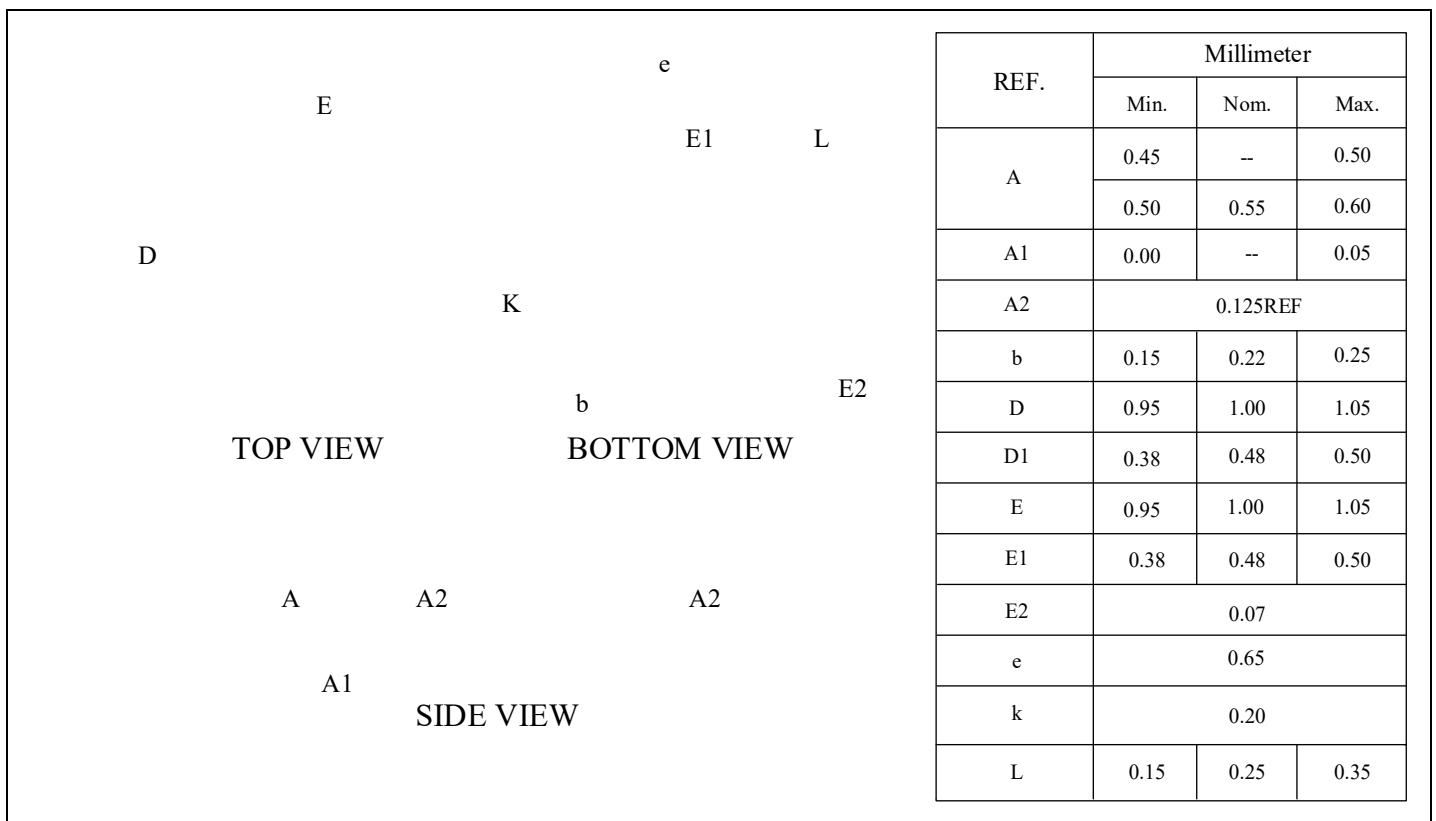

Packing Information

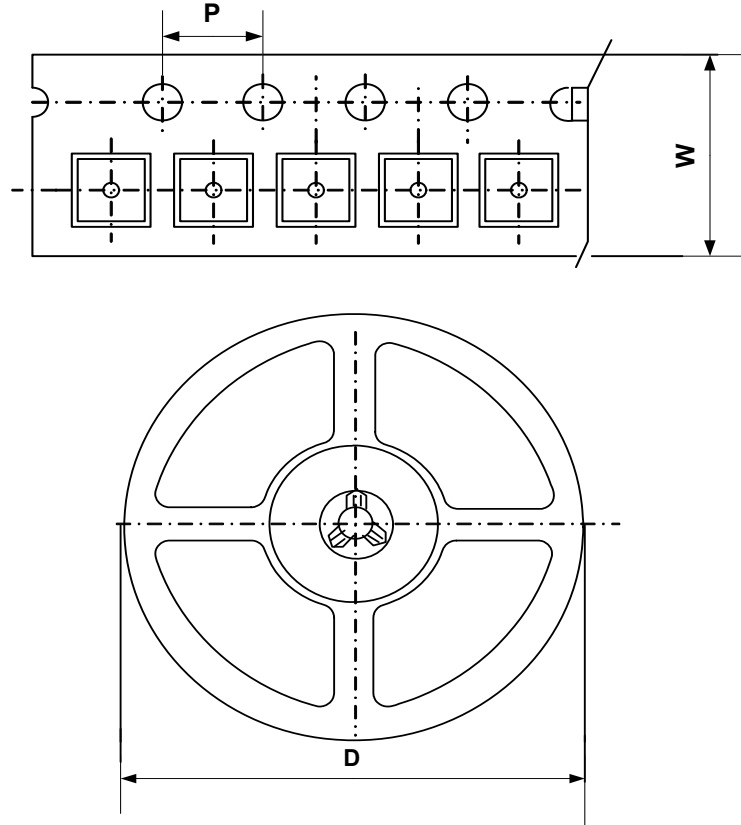

Type	W(mm)	P(mm)	D(mm)	Qty (pcs)
SOT23-5	8.0mm	4.0mm	178.0mm	3000pcs
DFN4	8.0mm	4.0mm	178.0mm	10000pcs

Legal Disclaimer

The information given in this document shall in no event be regarded as a guarantee of conditions or characteristics. With respect to any examples or hints given herein, any typical values stated herein and/or any information regarding the application of the device, Oriental Semiconductor hereby disclaims any and all warranties and liabilities of any kind, including without limitation, warranties of non-infringement of intellectual property rights of any third party.

For further information on technology, delivery terms and conditions and prices, please contact the Oriental Semiconductor sales representatives (www.orientalsemi.com).

© Oriental Semiconductor Co., Ltd. All Rights Reserved 