

45V,350mA,2.8uA,High PSRR,Low-Dropout Voltage Regulator With Enable

Features

- Low quiescent current : 2.8uA
- Shutdown current : 130nA
- Wide input voltage range : 3V to 45V
- High output current : 350mA
- High PSRR : 83dB at 1kHz
- Low dropout voltage : 320mV at 100mA
- Fixed output voltages : 1.8V, 3.0V, 3.3V and 5.0V
- Output voltage accuracy : $\pm 1\%/\pm 2\%$
- Fast transient response
- Current limit protection
- Short circuit protection
- Thermal shutdown protection
- Available packages : SOT23-3,SOT89-3,SOT223-3, SOT23-5 and TO252-3

Applications

- Battery-powered equipment
- Smoke detector and sensor
- Micro controller applications
- Home appliance

Description

The OSU24XXA/B series is an ultra-small, low dropout (LDO) linear regulator that can source 350mA of output current. The OSU24XXA/B series is designed to provide high PSRR, high input voltage, and excellent load and line transient performance.

The OSU24XXA/B series has thermal shutdown, current limit, and short circuit protections for added safety.

Shutdown mode is enabled by pulling the EN pin low.

The OSU24XXA/B series contains four fixed output voltages of 1.8V, 3.0V, 3.3V and 5.0V.

PART NUMBER	PACKAGE	BODY SIZE(NOM)
OSU24XXA/BTE	SOT23-3	2.9mm*2.8mm
OSU24XXA/BTS	SOT89-3	4.5mm*4.2mm
OSU24XXA/BTG	SOT23-5	2.9mm*2.8mm
OSU24XXA/BTM	SOT223-3	3.5mm*6.5mm
OSU24XXA/BTQ	TO252-3	6.5mm*10.0mm

Typical Application

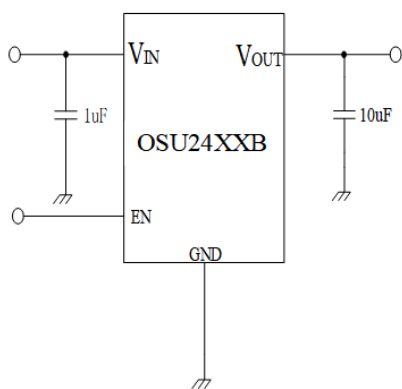

45V, Low-Dropout Voltage Regulator

PSRR

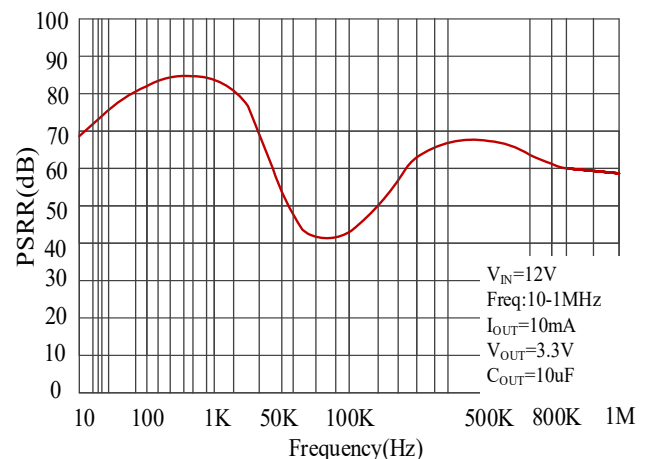

Pin Configuration and Functions

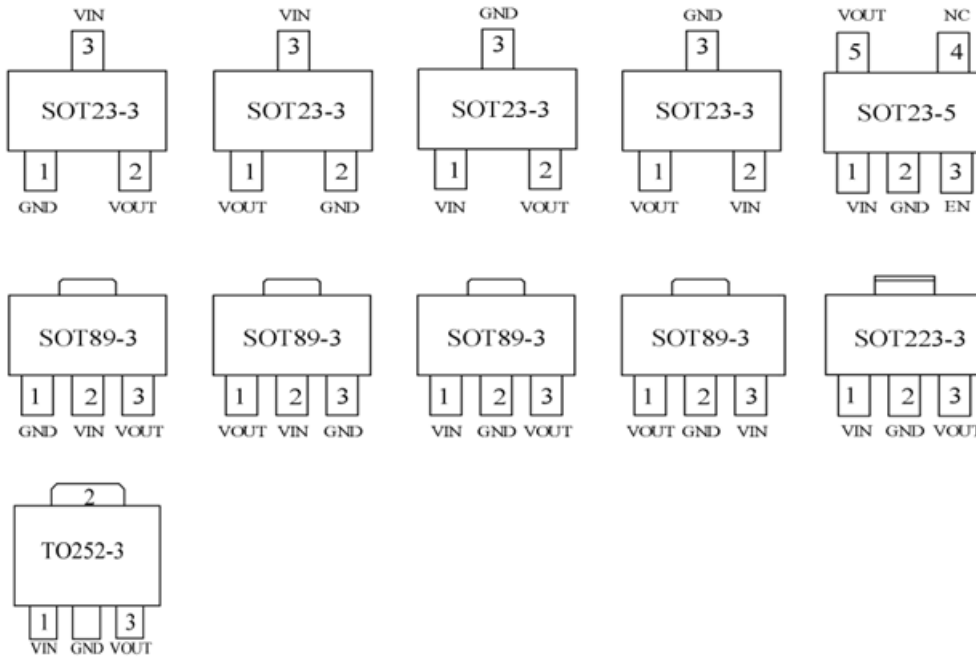

Name	SOT23-3				Description
	OSU24XXA/BTE	OSU24XXA/BTE-A	OSU24XXA/BTE-B	OSU24XXA/BTE-C	
GND	1	2	3	3	Ground pin
VOUT	2	1	2	1	Output pin
VIN	3	3	1	2	Input pin
Name	SOT89-3				Description
	OSU24XXA/BTS	OSU24XXA/BTS-A	OSU24XXA/BTS-B	OSU24XXA/BTS-C	
GND	1	3	2	2	Ground pin
VOUT	3	1	3	1	Output pin
VIN	2	2	1	3	Input pin
Name	SOT23-5	SOT223-3	TO252-3		Description
	OSU24XXA/BTG	OSU24XXA/BTM	OSU24XXA/BTQ		
VIN	1	1	1		Input pin
GND	2	2	2		Ground pin
EN	3				Enable pin
NC	4				No connection
VOUT	5	3	3		output Pin

Absolute Maximum Ratings

Parameter	Description	Min	Max	Unit
Input voltage	VIN to GND	-0.3	55	V
	VOUT to GND	-0.3	7	V
	VIN to VOUT	-0.3	50	V
	EN to GND	-0.3	55	V
Current	Peak output current	Internally limited		
Temperature	Operating temperature range	-40	125	°C
	Storage temperature	-40	150	°C
Thermal resistance (Junction to ambient)	SOT89-3	130		°C/W
	SOT23-3	200		°C/W
	SOT23-5	200		°C/W
	SOT223-3	120		°C/W
	TO252-3	80		°C/W
Power dissipation	SOT89-3	900		mW
	SOT23-3	600		mW
	SOT23-5	600		mW
	SOT223-3	1000		mW
	TO252-3	1700		mW

Note:

exceeding the range specified by the rated parameters will cause damage to the chip, and the working state of the chip beyond the range of rated parameters cannot be guaranteed. Exposure outside the rated parameter range will affect the reliability of the chip.

ESD Ratings

Parameter	Description	Range	Unit
V _{ESD}	Human body model(HBM)	4	KV

Note:

JEDEC document JEP155 states that 500-V HBM allows safe manufacturing with a standard ESD control process.

Electrical Characteristics

(At $T_A=25^{\circ}\text{C}$, $C_{IN}=1\mu\text{F}$, $V_{IN}=V_{OUTNOM}+1.0\text{V}$, $C_{OUT}=10\mu\text{F}$, unless otherwise noted)

Symbol	Parameter	Test Conditions	Min	Typ	Max	Unit
V_{IN}	Operating input voltage		3	—	45	V
I_{GND}	Quiescent current	$V_{IN}=12\text{V}$, No load	2.5	2.8	3.2	μA
I_{SHUT}	Shutdown current	$V_{IN}=12\text{V}$, $EN=0\text{V}$	—	130	—	nA
V_{OUT}	Output voltage	$V_{IN}=12\text{V}$, $I_{OUT}=10\text{mA}$	$V_{OUTNOM} * 0.98$	V_{OUTNOM}	$V_{OUTNOM} * 1.02$	V
I_{OUT_MAX}	Output current		350	—	—	mA
V_{DROP}	Dropout voltage ⁽¹⁾	$I_{OUT}=10\text{mA}$, $V_{IN}=V_{OUTNOM}-0.1\text{V}$	—	35	—	mV
		$I_{OUT}=100\text{mA}$, $V_{IN}=V_{OUTNOM}-0.1\text{V}$	—	320	—	mV
$\Delta V_{OUT}/\Delta I_{OUT_T}$	Load regulation	$V_{IN}=7\text{V}$, $1\text{mA} \leq I_{OUT} \leq 100\text{mA}$	—	0.1	—	mV/mA
$\Delta V_{OUT}/\Delta V_{IN}$	Line regulation	$I_{OUT}=1\text{mA}$, $V_{OUTNOM}+0.5\text{V} \leq V_{IN} \leq 45\text{V}$	—	0.1	—	mV/V
I_{LIMIT}	Current limit		—	700	—	mA
T_{SHDN}	Thermal shutdown temperature	Shutdown, temperature increasing	—	150	—	$^{\circ}\text{C}$
		Reset, temperature decreasing	—	130	—	
PSRR		$V_{IN}=10\text{V}$, $I_{OUT}=10\text{mA}$ $f=1\text{kHz}$, $V_{OUT}=5\text{V}$	—	83	—	dB
V_{ENH}	EN high level	Enabled	1	—	—	V
V_{ENL}	EN low level	Shutdown	—	—	0.4	V

Note:

(1) Dropout Voltage is the voltage difference between the input and the output at which the output voltage drops 2% below its nominal value.

Typical Characteristics

(Test condition: $T_A=25^{\circ}\text{C}$, $V_{IN}=12\text{V}$, $I_{OUT}=1\text{mA}$, $C_{OUT}=10\mu\text{F}$, $V_{OUT}=3.3\text{V}$ unless otherwise note)

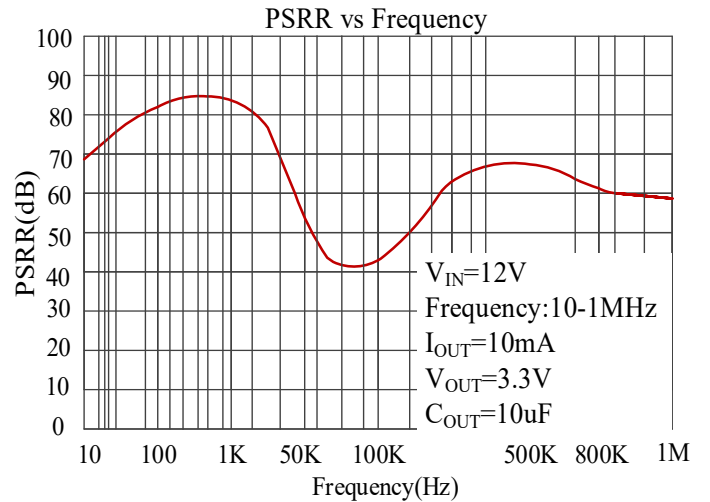
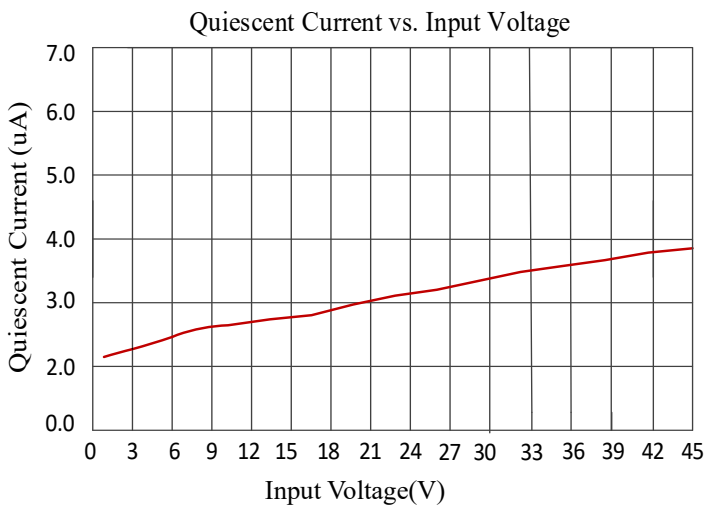
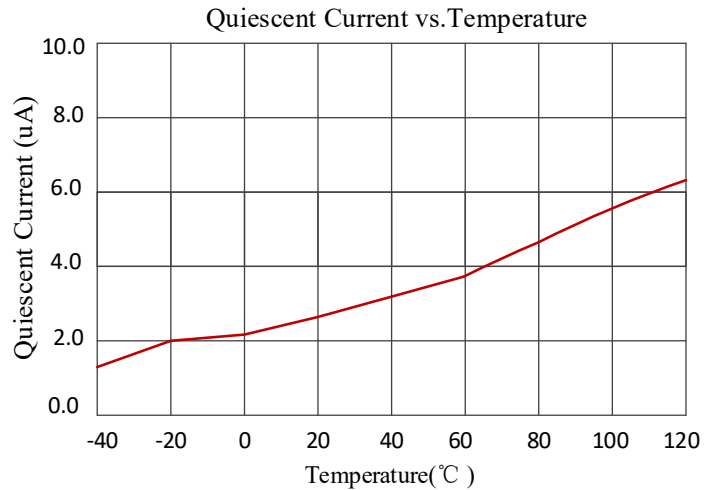
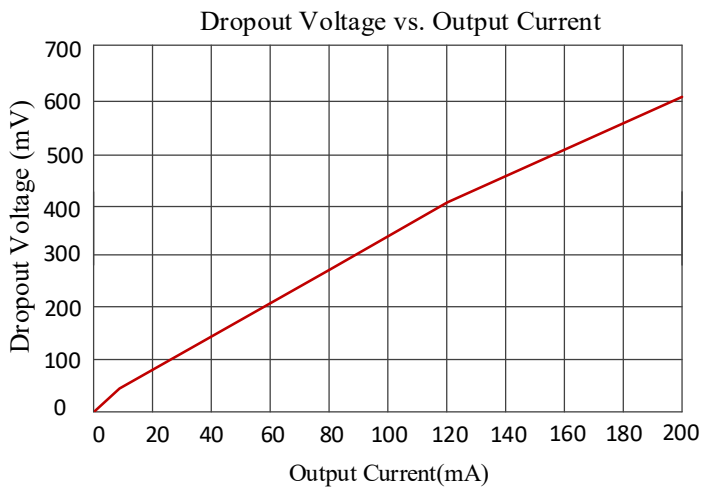
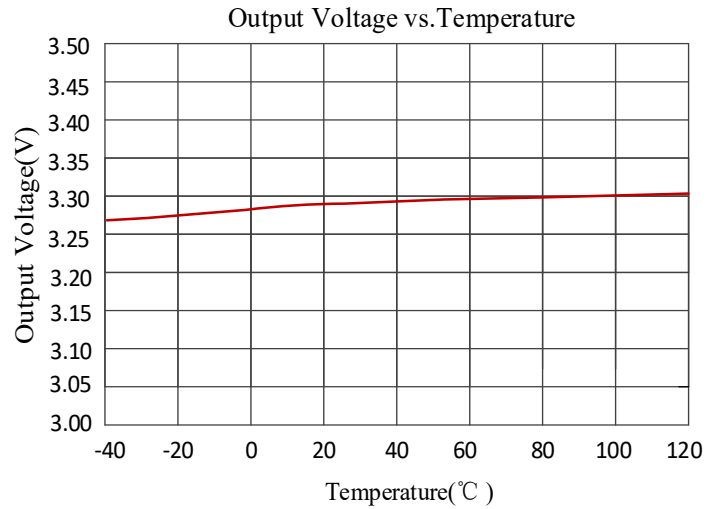
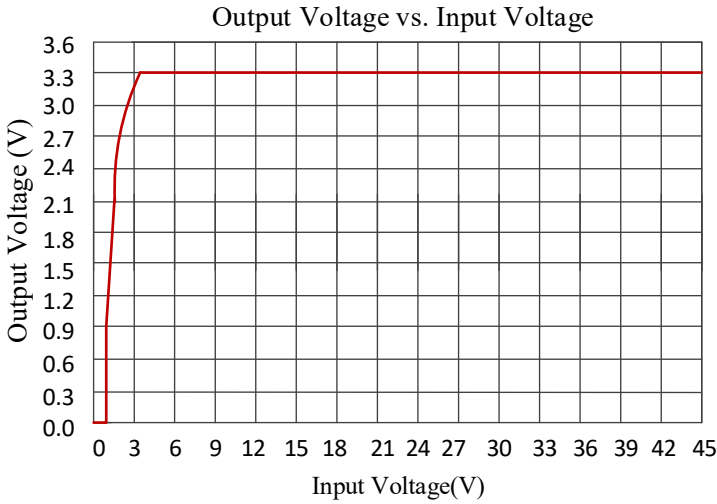

Line Transient Response

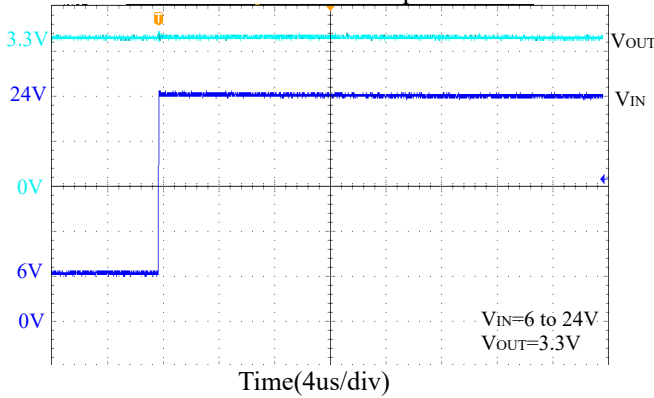

Line Transient Response

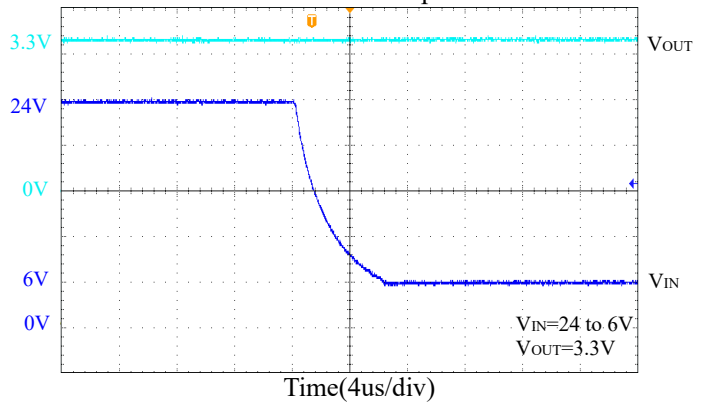

Load Transient Response

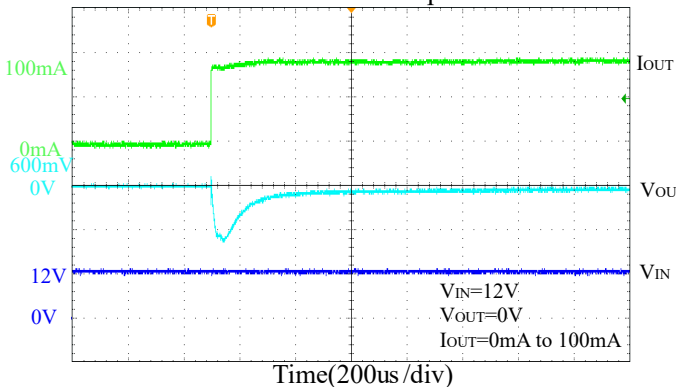

Load Transient Response

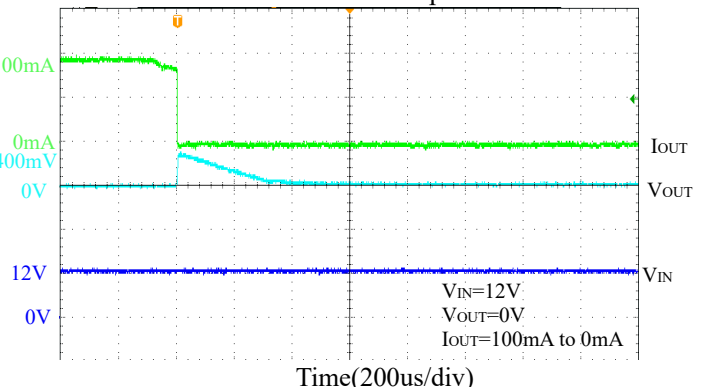

Start Up

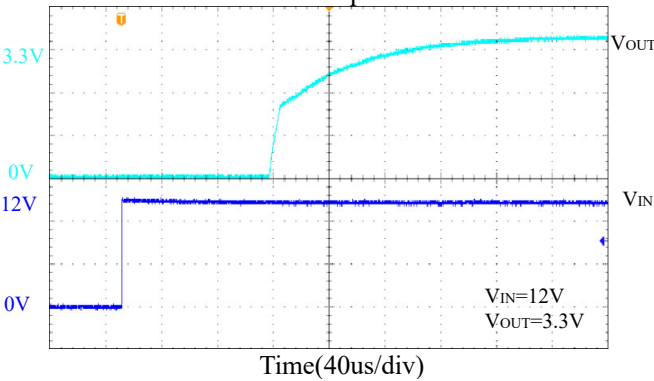

Start Up

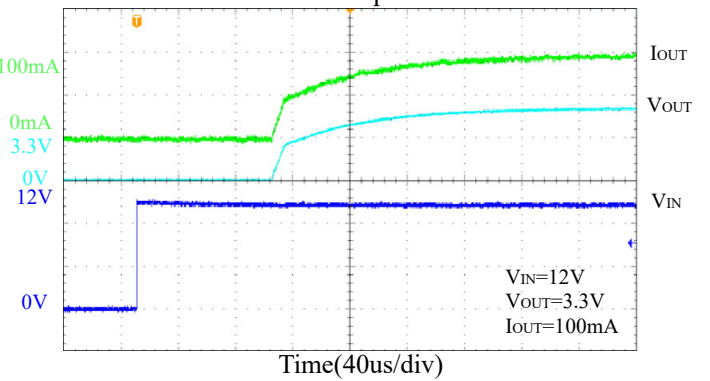

Short Circuit Protection

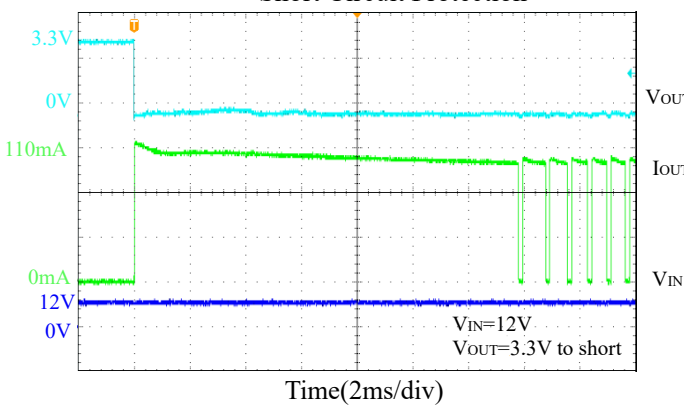

Short Circuit Protection

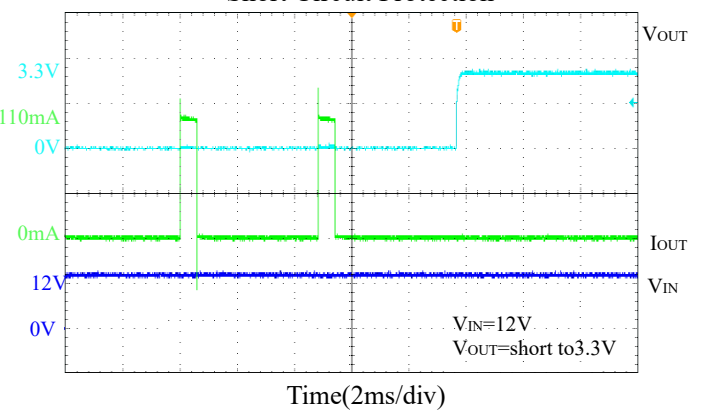

Detailed Description

Overview

The OSU24XXA/B series products are 350mA wide input voltage range linear regulators with very low quiescent current. These voltage regulators operate from 3V to 45V DC input voltage with supporting 45V transient input voltage and consume 2.8uA quiescent current at no load.

The OSU24XXA/B series products are available in fixed voltage versions of 1.8V, 3.0V, 3.3V and 5.0V. The series products are available in SOT23-3, SOT89-3, SOT23-5, SOT223-3 and TO252-3 packages.

Functional Block Diagram

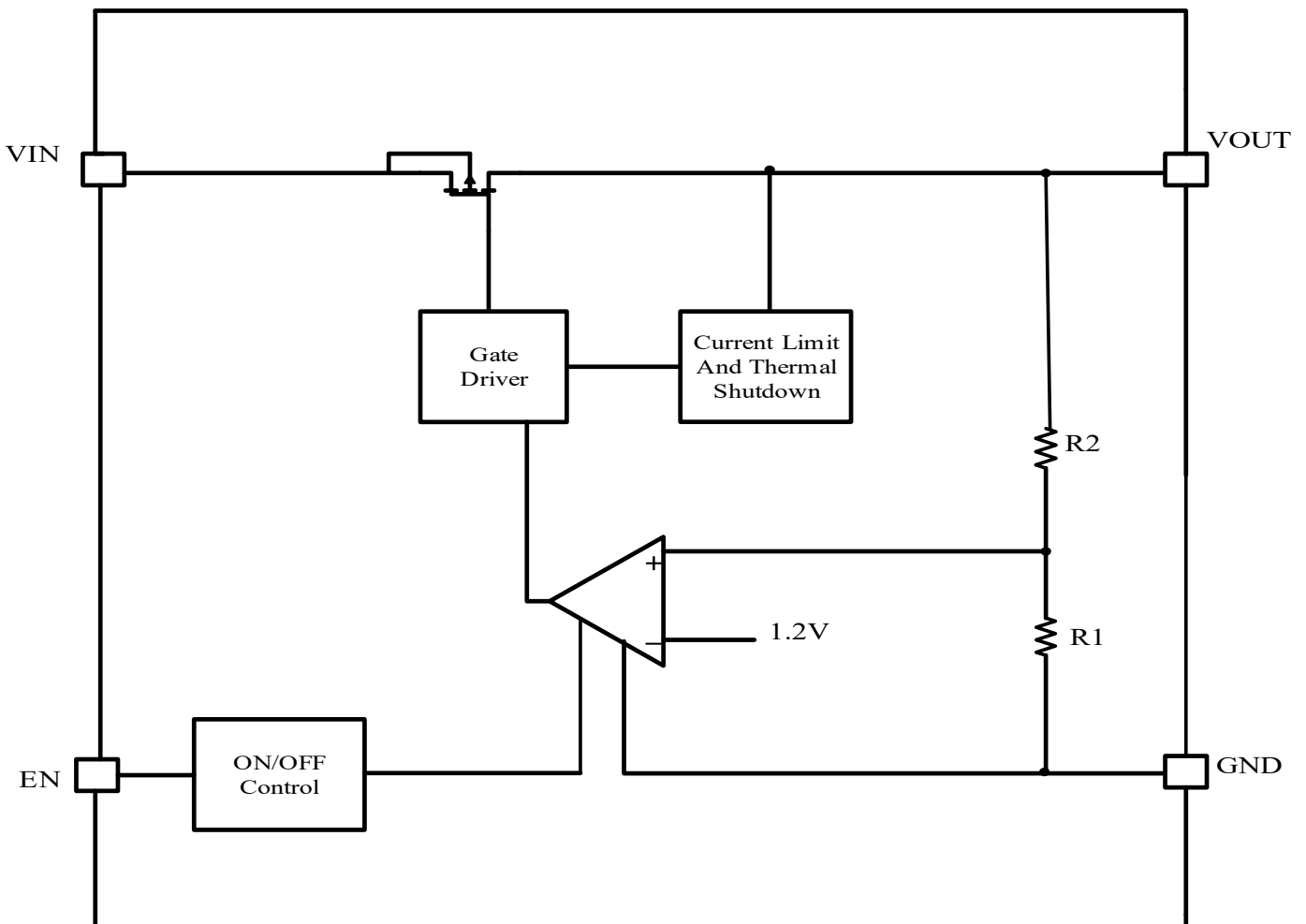

Functional Block Diagram

Regulated Output Voltage

The OSU24XXA/B series are available in fixed voltage versions of 1.8V, 3V, 3.3V and 5V. When the input voltage is higher $V_{OUT(NOM)} + V_{DROPO}$, output pin is the regulated output based on the selected voltage version. When the input voltage falls below $V_{OUT(NOM)} + V_{DROPO}$, output pin tracks the input voltage minus the dropout voltage based on the load current. When the input voltage drops below UVLO threshold, the output keeps shut off.

Input Capacitor and Output Capacitor

A 1 μ F ceramic capacitor is recommended to connect between VIN and GND pins to decouple input power supply glitch and noise. The amount of the capacitance may be increased without limit. This input capacitor must be located as close as possible to the device to assure input stability and less noise. For PCB layout, a wide copper trace is required for both VIN and GND. When $V_{IN} \geq 18V$, it is recommended to add R1 ($R1 > 1\Omega$, the resistance shall be adjusted according to the actual application) at the input end.

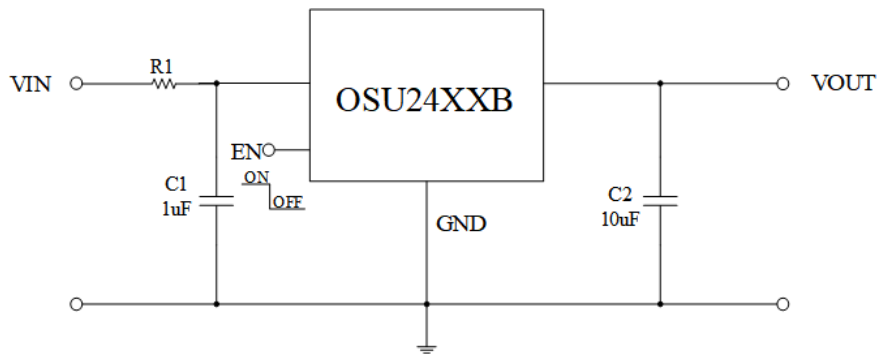

An output capacitor is required for the stability of the LDO. The recommended minimum output capacitance is 10 μ F, ceramic capacitor is recommended, and temperature characteristics are X5R or X7R. Higher capacitance values help to improve load/line transient response. The output capacitance may be increased to keep low undershoot/overshoot. Place output capacitor as close as possible to VOUT and GND pins.

EN Pin Operation

The OSU24XXA/B is turned on by setting the EN pin to “H”. Since the EN pin is neither pulled down nor pulled up internally, do not set it in floating status. When the EN pin is not used, connect the EN pin with VIN to keep the LDO in operating mode.

Current Limit and Short Circuit Protection

When output current at VOUT pin is higher than current limit threshold or the VOUT pin is direct short to GND, the current limit protection will be triggered and clamp the output current at a pre-designed level to prevent over-current and thermal damage.

Power Dissipation and Thermal Protection

The OSU24XXA/B has internal thermal sense and protection circuits. When excessive power dissipation happens on the device, such as short circuit at the output pin or very heavy load current with a large voltage drop across the device, the internal thermal protection circuit will be triggered, and it will shut down the power MOSFET to prevent the LDO from damage. As soon as excessive thermal condition is removed and the temperature of the device drops down, the thermal protection circuit will lease the control of the power MOSFET, and the LDO device goes to normal operation. Power dissipation caused by voltage drop across the LDO and by the output current flowing through the device needs to be dissipated out from the chip. The maximum junction temperature is dependent on power dissipation, package, the PCB layout, number of used Cu layers, Cu layers thickness and the ambient temperature. During normal operation, LDO junction temperature should not exceed 150°C, or else it may result in deterioration of the properties of the chip. Using below equations to calculate the power dissipation and estimate the junction temperature. The power dissipation can be calculated using Equation (1).

$$P_D = (V_{IN} - V_{OUT}) \times I_{OUT} \quad (1)$$

The junction temperature can be estimated using Equation. $R_{\theta JA_EVM}$ is the junction-to-ambient thermal resistance based on customer's PCB. Verify the application and allow sufficient margins in the thermal design by the Equation (2).

$$T_J = T_A + P_D \times R_{\theta JA_EVM} \quad (2)$$

$R_{\theta JA_EVM}$ is a critical parameter and depends on many factors such as the following:

- Power dissipation
- Air temperature/flow
- PCB area
- Copper heat-sink area
- Number of thermal vias under the package
- Adjacent component placement

Ordering And Marking Information

Part Number						
	Package Outline	SOT23-5	SOT23-3	SOT89-3	SOT223-3	TO252-3
	Minimum Package	SOT23-5 3000pcs/Reel	SOT23-3 3000pcs/Reel	SOT89-3 1000pcs/Reel	SOT223-3 1000pcs/Reel	SOT252-3 2500pcs/Reel
	Marking	<p> 24XX B B: B(±2%) A(±1%) C(±3%) 24XX: 2433(3.3V) 2418(1.8V) 2430(3.0V) 2450(5.0V) </p> <p> 429 X X: Internal Code. Variable. 429: 4=2024; 29=the 29th week of this year </p>			<p>Output voltage</p> <p>XX</p> <p>XX</p> <p>Year and week number</p> <p>4=2024, 5=2025...</p> <p>A=week 1</p> <p>a=week 27...</p>	

Package Outline

SOT223-3

	REF.	Millimeter	
		Min.	Max.
A2	1.5	1.7	
a	0.45	0.55	
b	0.66	0.84	
c	0.23	0.35	
D	6.30	6.70	
D1	2.90	3.10	
E	2.40	2.60	
E1	3.30	3.70	
e	2.20	2.30	
e1	4.40	4.60	
L1	0.80	1.00	
L2	0.65	0.75	

SOT23-3

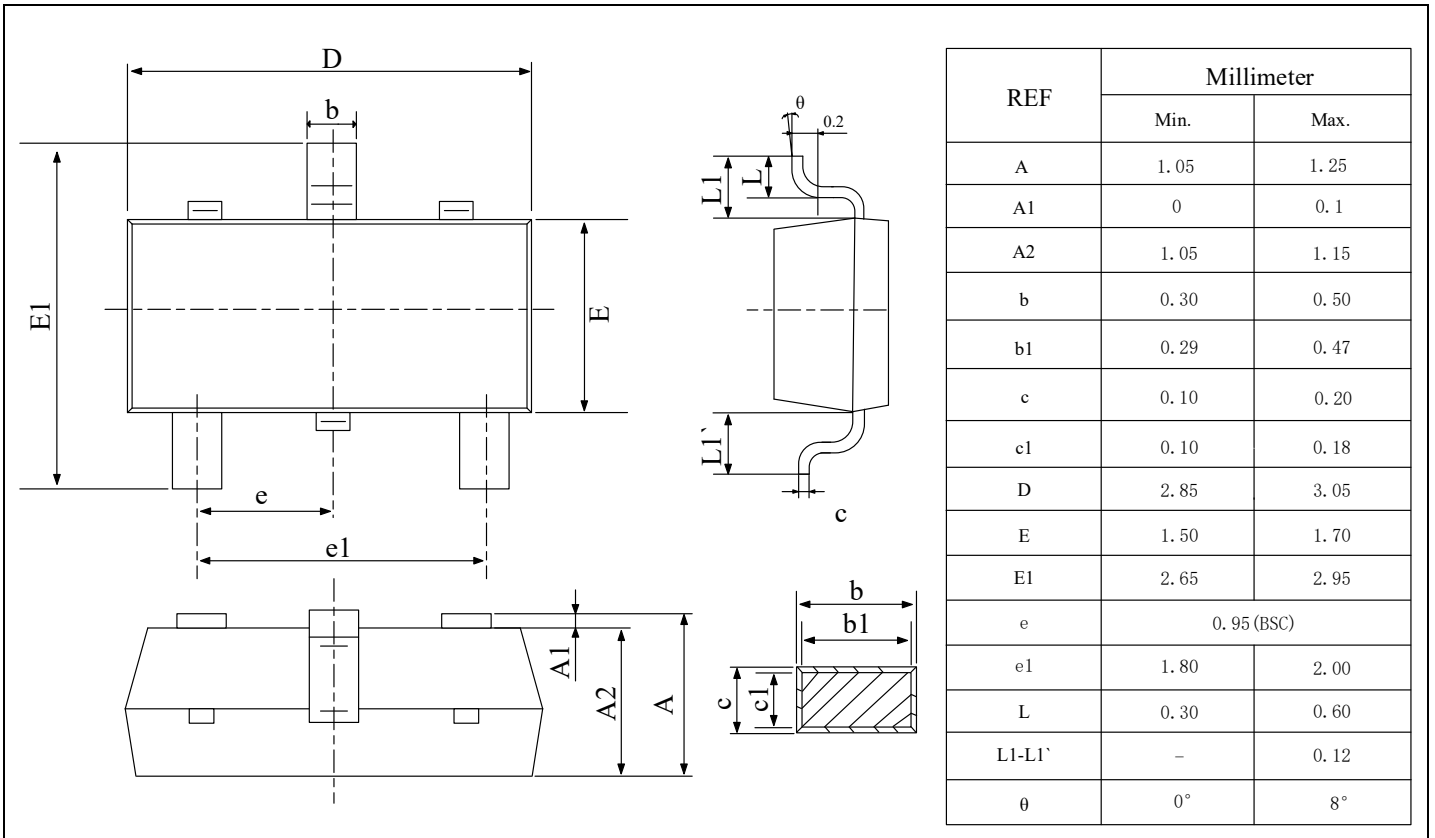

SOT89-3

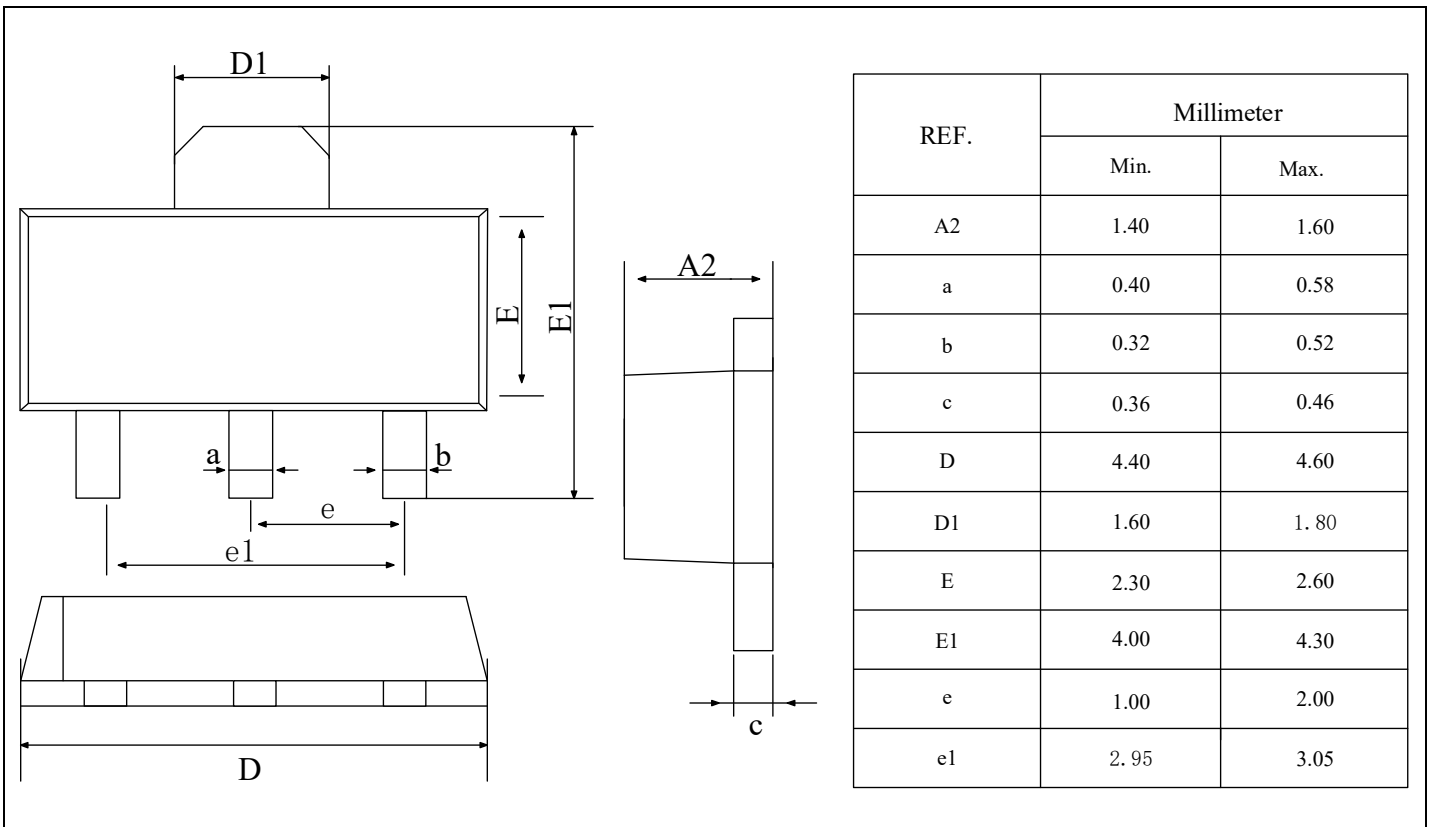

SOT23-5

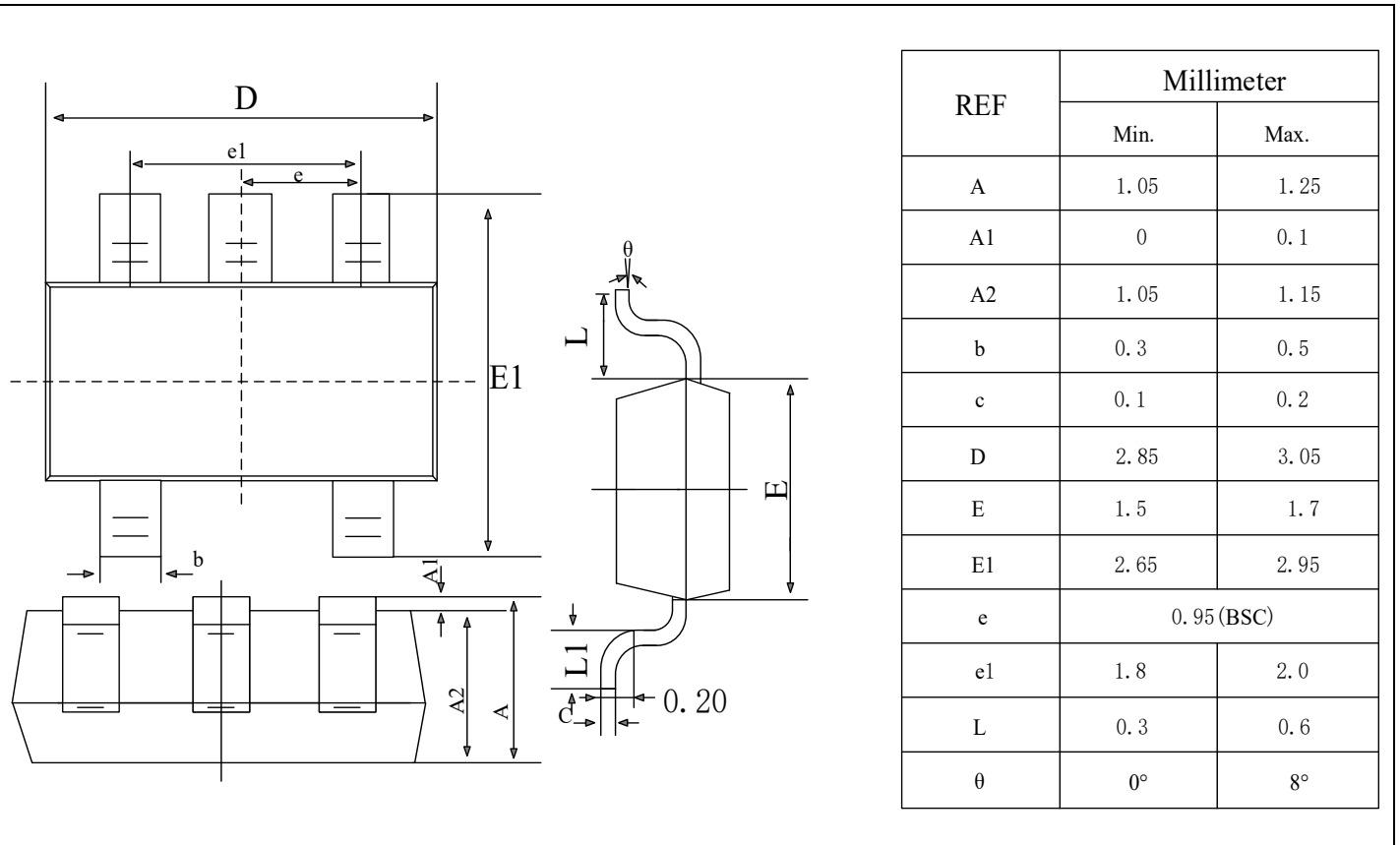

TO252-3

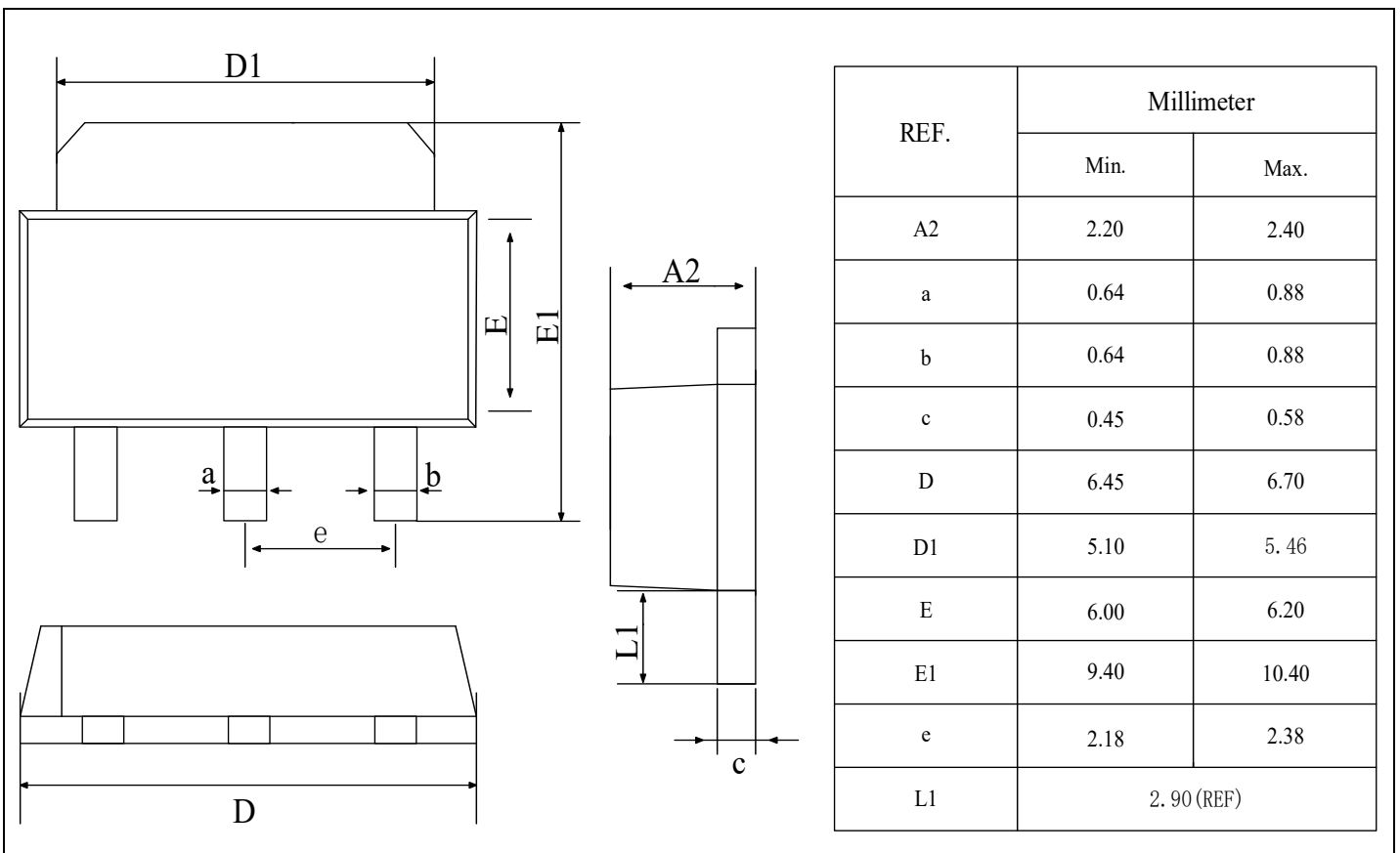

Packing Information

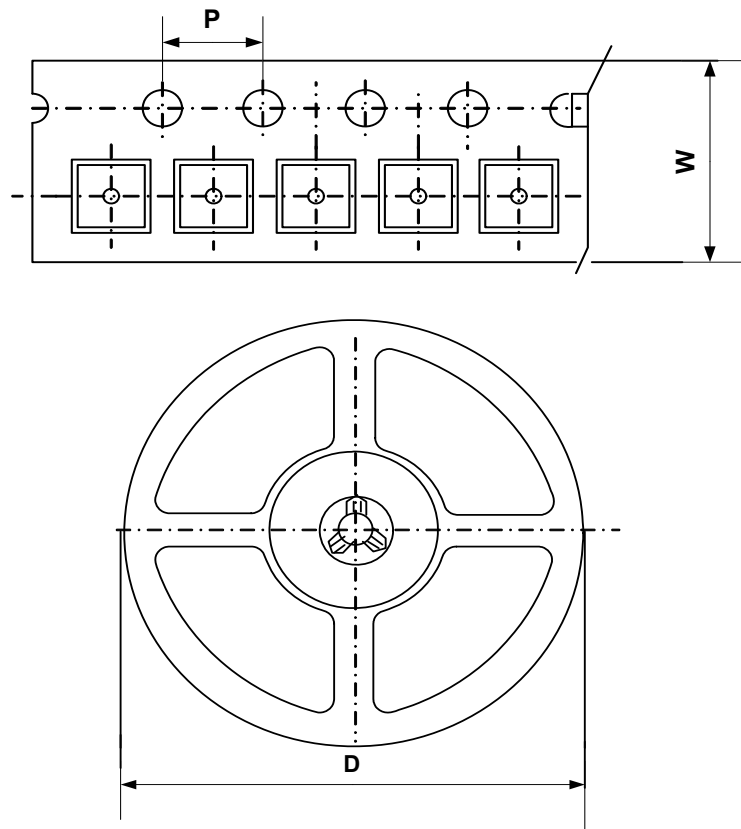

Type	W(mm)	P(mm)	D(mm)	Qty (pcs)
SOT23-3	8.0mm	4.0mm	178.0mm	3000pcs
SOT23-5	8.0mm	4.0mm	178.0mm	3000pcs
SOT89-3	12.0mm	4.0mm	178.0mm	1000pcs
SOT223-3	12.0mm	4.0mm	330.0mm	1000pcs
TO252-3	16.0mm	4.0mm	330.0mm	2500pcs

Legal Disclaimer

The information given in this document shall in no event be regarded as a guarantee of conditions or characteristics. With respect to any examples or hints given herein, any typical values stated herein and/or any information regarding the application of the device, Oriental Semiconductor hereby disclaims any and all warranties and liabilities of any kind, including without limitation, warranties of non-infringement of intellectual property rights of any third party.

For further information on technology, delivery terms and conditions and prices, please contact the Oriental Semiconductor sales representatives (www.orientalsemi.com).

© **Oriental Semiconductor Co.,Ltd. All Rights Reserved** 