

General Description

The silicon carbide power MOSFET utilizes Oriental-Semi's advanced technology to achieve low on-resistance, low gate charge, low Qrr and excellent thermal performance by exploiting innovative properties of wide bandgap materials. It is engineered to minimize conduction loss and provide superior switching performance almost independent of temperature.

The silicon carbide power MOSFET provides high reliability and extremely high efficiency. It is targeted to improve application performance in frequency, energy efficiency, reliability, system size and weight reduction.

Features

- High blocking voltage with low on-resistance
- High-speed switching with low capacitances
- IGBT-compatible driving voltage (15V for turn-on)
- Fast intrinsic diode with low reverse recovery (Qrr)
- Temperature independent turn-off switching losses
- Halogen free, RoHS compliant



Applications

- Solar inverters
- On-board charger/PFC
- EV motor drive
- High voltage DC/DC converters
- Switch mode power supplies

Key Performance Parameters

| Parameter | Value | Unit |
|-----------------------------------|-------|------------|
| V_{DS} | 1200 | V |
| I_D , pulse | 77 | A |
| $R_{DS(ON)}$, typ @ $V_{GS}=18V$ | 75 | m Ω |
| Q_g | 32.6 | nC |

Marking Information

| Product Name | Package | Marking |
|-----------------|---------|----------------|
| OSQ120R070K9T3F | T2PAK | OSQ120R070K9T3 |

Package & Pin Information

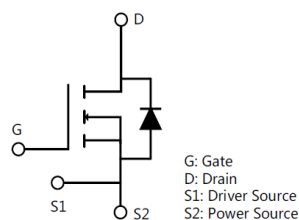
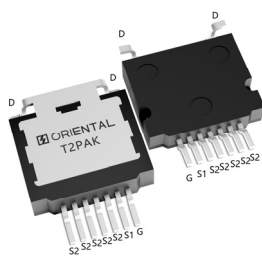

Absolute Maximum Ratings at $T_j=25^\circ\text{C}$ unless otherwise noted

| Parameter | Symbol | Value | Unit |
|--|----------------|------------|------------------|
| Drain-source voltage | V_{DS} | 1200 | V |
| Gate-source voltage (max static) | V_{GS} | -8/+22 | V |
| Gate-source voltage (recommended operating values) | V_{GS} | -4/+18 | V |
| Continuous drain current ¹⁾ , $T_C=25^\circ\text{C}$ | I_D | 30 | A |
| Continuous drain current ¹⁾ , $T_C=100^\circ\text{C}$ | | 21 | |
| Pulsed drain current ²⁾ | $I_{D, pulse}$ | 77 | A |
| Power dissipation ³⁾ , $T_C=25^\circ\text{C}$ | P_D | 132 | W |
| Operation and storage temperature | T_{stg}, T_j | -55 to 175 | $^\circ\text{C}$ |

Thermal Characteristics

| Parameter | Symbol | Min. | Typ. | Max. | Unit |
|--------------------------------------|-----------------|------|------|------|--------------------|
| Thermal resistance, junction-case | $R_{\theta JC}$ | | 0.87 | 1.13 | $^\circ\text{C/W}$ |
| Thermal resistance, junction-ambient | $R_{\theta JA}$ | | | 62 | $^\circ\text{C/W}$ |

Electrical Characteristics at $T_j=25^\circ\text{C}$ unless otherwise specified

| Parameter | Symbol | Min. | Typ. | Max. | Unit | Test condition |
|----------------------------------|--------------|------|------|-----------|---------------|--|
| Drain-source breakdown voltage | BV_{DSS} | 1200 | | | V | $V_{GS}=0\text{ V}, I_D=100\ \mu\text{A}$ |
| Gate threshold voltage | $V_{GS(th)}$ | 2.3 | 2.8 | 3.6 | V | $V_{DS}=V_{GS}, I_D=5\text{ mA}$ |
| Drain-source on-state resistance | $R_{DS(ON)}$ | | 75 | 97 | m Ω | $V_{GS}=18\text{ V}, I_D=18\text{ A}$ |
| | | | 137 | | | $V_{GS}=18\text{ V}, I_D=18\text{ A}, T_j=175^\circ\text{C}$ |
| | | | 91 | 118 | m Ω | $V_{GS}=15\text{ V}, I_D=18\text{ A}$ |
| | | | 145 | | | $V_{GS}=15\text{ V}, I_D=18\text{ A}, T_j=175^\circ\text{C}$ |
| Transconductance | g_{fs} | | 19 | | S | $V_{DS}=20\text{ V}, I_D=18\text{ A}$ |
| Gate-source leakage current | I_{GSS} | | | ± 100 | nA | $V_{GS}=-8\sim 22\text{ V}$ |
| Drain-source leakage current | I_{DSS} | | | 100 | μA | $V_{DS}=1200\text{ V}, V_{GS}=0\text{ V}$ |
| | | | | 500 | μA | $V_{DS}=1200\text{ V}, V_{GS}=0\text{ V}, T_j=175^\circ\text{C}$ |
| Gate resistance | R_G | | 5.2 | | Ω | $f=1\text{ MHz}, \text{Open drain}, V_{AC}=25\text{ mV}$ |

Dynamic Characteristics

| Parameter | Symbol | Min. | Typ. | Max. | Unit | Test condition |
|------------------------------|--------------|------|------|------|---------------|--|
| Input capacitance | C_{iss} | | 890 | | pF | $V_{GS}=0\text{ V}$, $V_{DS}=800\text{ V}$, $f=1\text{ MHz}$, $V_{AC}=25\text{ mV}$ |
| Output capacitance | C_{oss} | | 43 | | pF | |
| Reverse transfer capacitance | C_{rss} | | 0.6 | | pF | |
| C_{oss} stored energy | E_{OSS} | | 19 | | μJ | |
| Turn-on delay time | $t_{d(on)}$ | | 9.8 | | ns | $V_{GS}=-4/18\text{ V}$, $V_{DS}=800\text{ V}$, $R_G=5\ \Omega$, $I_D=18\text{ A}$, $L=120\ \mu\text{H}$, $T_j=25\text{ }^\circ\text{C}$ |
| Rise time | t_r | | 10.3 | | ns | |
| Turn-off delay time | $t_{d(off)}$ | | 16.6 | | ns | |
| Fall time | t_f | | 6.8 | | ns | |
| Turn-on switching energy | E_{on} | | 147 | | μJ | |
| Turn-off switching energy | E_{off} | | 24 | | μJ | |
| Turn-on switching energy | E_{on} | | 140 | | μJ | |
| Turn-off switching energy | E_{off} | | 27 | | μJ | |

Gate Charge Characteristics

| Parameter | Symbol | Min. | Typ. | Max. | Unit | Test condition |
|--------------------|----------|------|------|------|------|---|
| Total gate charge | Q_g | | 32.6 | | nC | $V_{GS}=-4/18\text{ V}$, $V_{DS}=800\text{ V}$, $I_D=18\text{ A}$ |
| Gate-source charge | Q_{gs} | | 12.1 | | nC | |
| Gate-drain charge | Q_{gd} | | 6.4 | | nC | |

Body Diode Characteristics

| Parameter | Symbol | Min. | Typ. | Max. | Unit | Test condition |
|----------------------------------|-----------|------|------|------|------|--|
| Diode forward voltage | V_{SD} | | 4.5 | | V | $I_S=13\text{ A}$, $V_{GS}=-4\text{ V}$, $T_J=25\text{ °C}$ |
| | | | 3.9 | | V | $I_S=13\text{ A}$, $V_{GS}=-4\text{ V}$, $T_J=175\text{ °C}$ |
| Continuous diode forward current | I_S | | 30 | | A | $V_{GS}=-4\text{ V}$, $T_J=25\text{ °C}$ |
| Reverse recovery time | t_{rr} | | 9.2 | | ns | $V_{GS}=-4\text{ V}$, $V_R=800\text{ V}$, |
| Reverse recovery charge | Q_{rr} | | 66 | | nC | $I_S=18\text{ A}$, |
| Peak reverse recovery current | I_{rrm} | | 12.8 | | A | $di/dt=3000\text{ A}/\mu\text{s}$, $T_J=25\text{ °C}$ |
| Reverse recovery time | t_{rr} | | 71.4 | | ns | $V_{GS}=-4\text{ V}$, $V_R=800\text{ V}$, |
| Reverse recovery charge | Q_{rr} | | 305 | | nC | $I_S=18\text{ A}$, |
| Peak reverse recovery current | I_{rrm} | | 7.5 | | A | $di/dt=1000\text{ A}/\mu\text{s}$, $T_J=175\text{ °C}$ |

Note

- 1) Calculated continuous current based on maximum allowable junction temperature.
- 2) Repetitive rating; pulse width limited by max. junction temperature.
- 3) P_d is based on max. junction temperature, using junction-case thermal resistance.

Electrical Characteristics Diagrams

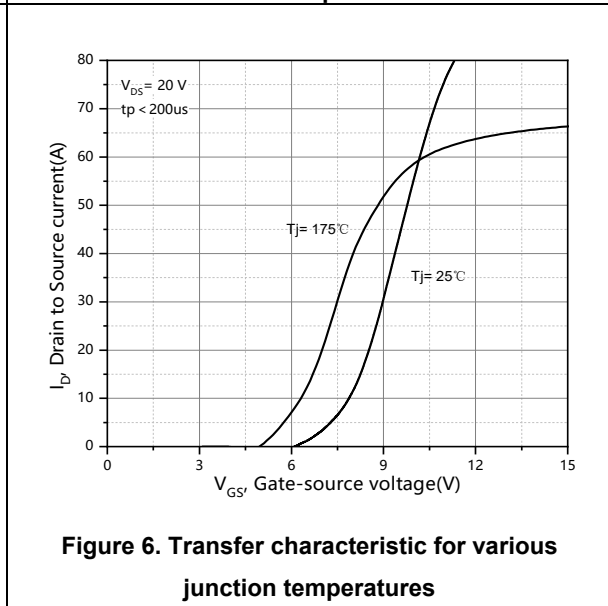
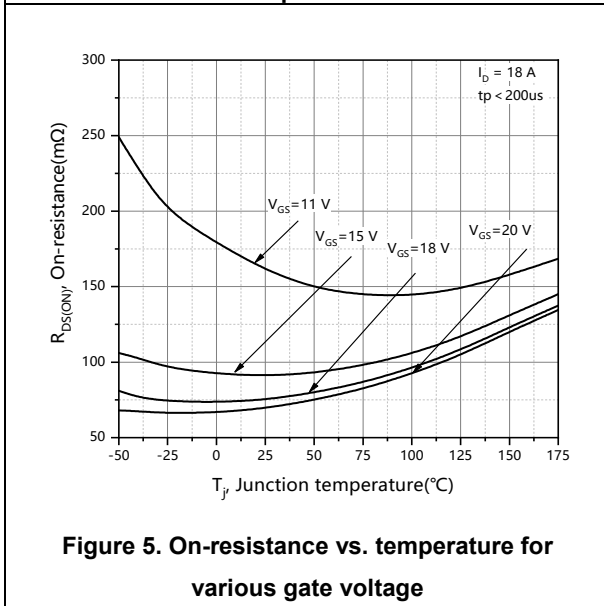
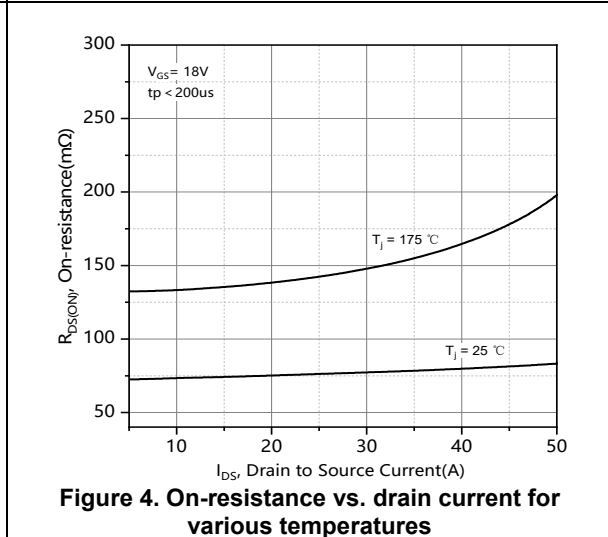
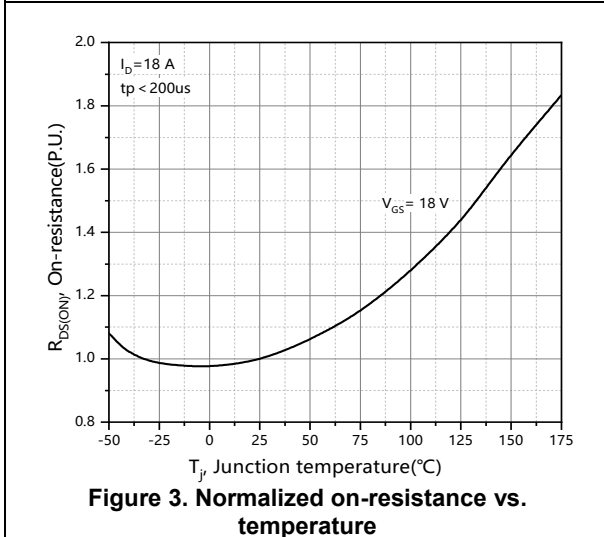
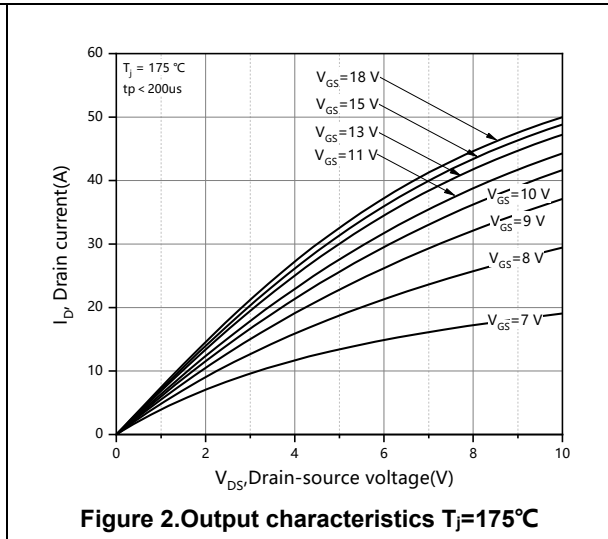
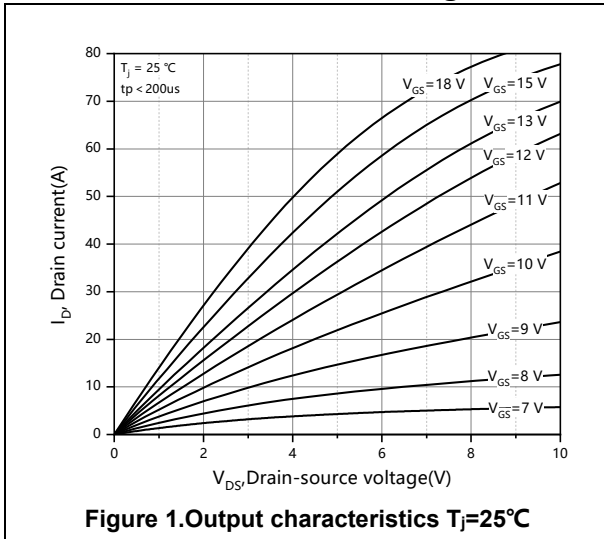

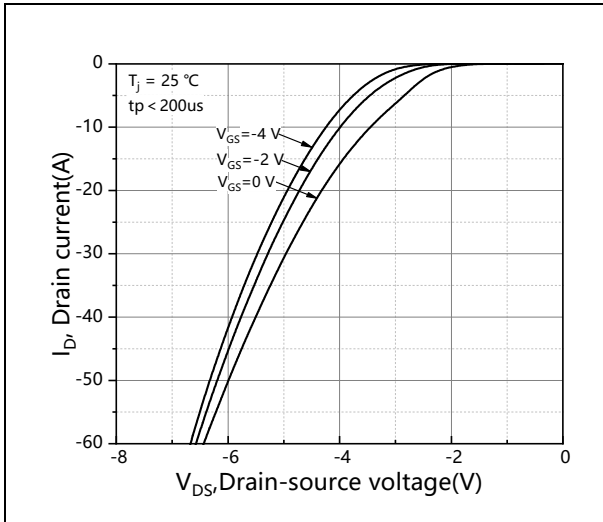

Figure 7. Body diode characteristic at $T_j = 25\text{ }^\circ\text{C}$

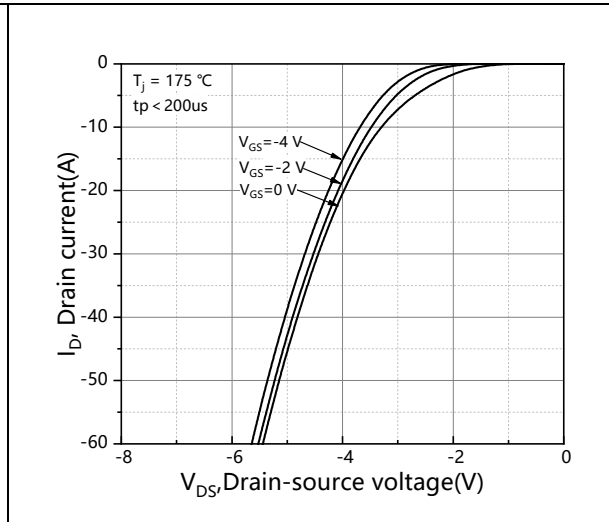

Figure 8. Body diode characteristic at $T_j = 175\text{ }^\circ\text{C}$

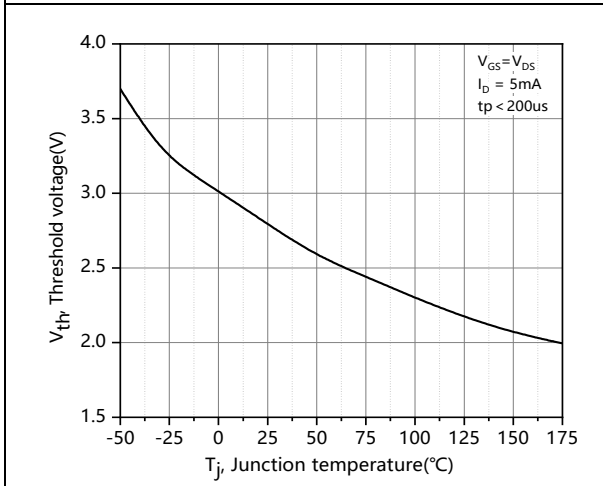

Figure 9. Threshold voltage vs. temperature

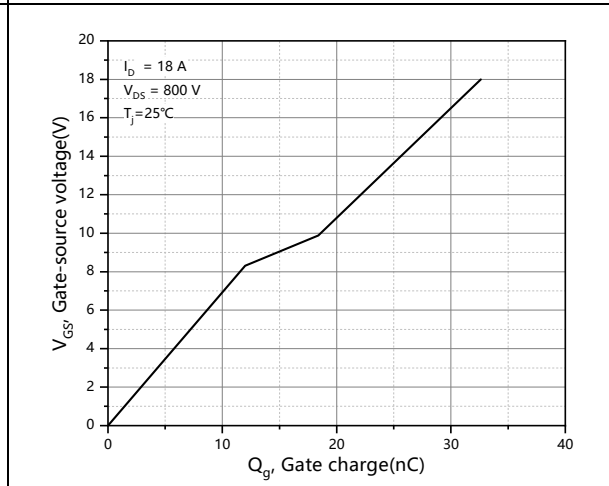

Figure 10. Gate charge characteristic

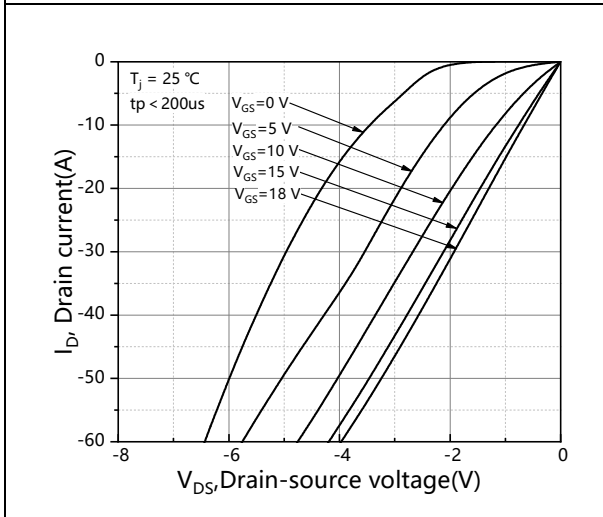

Figure 11. 3rd quadrant characteristic at $T_j = 25\text{ }^\circ\text{C}$

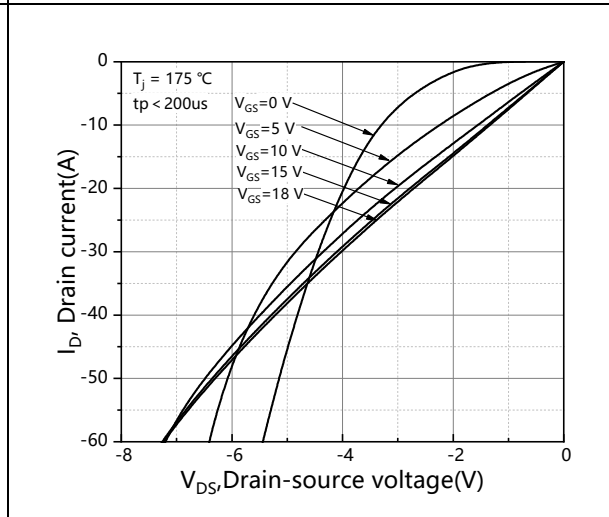
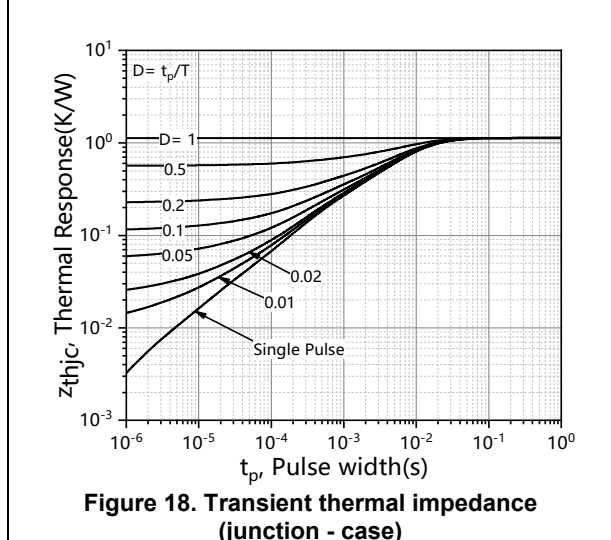
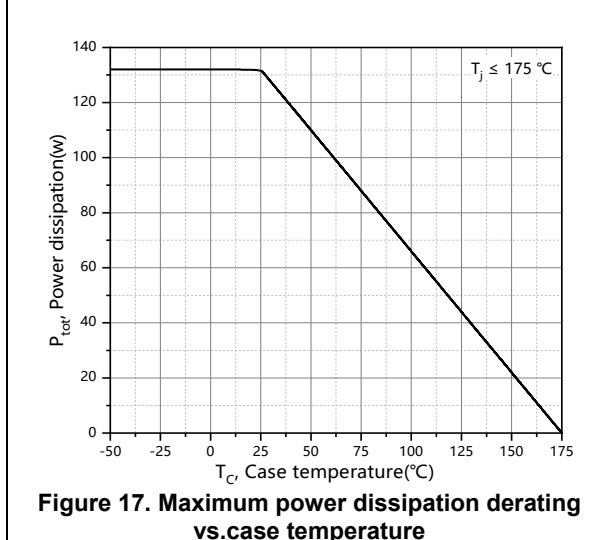
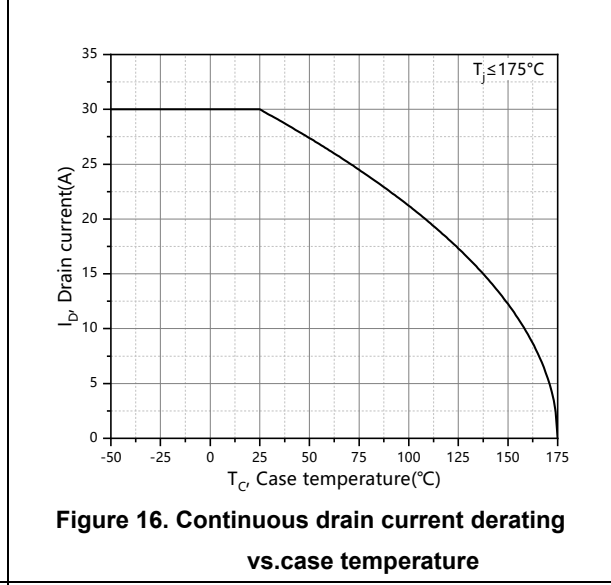
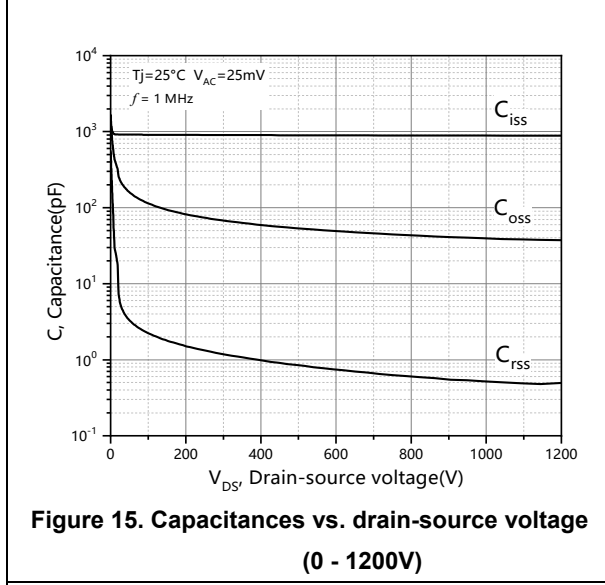
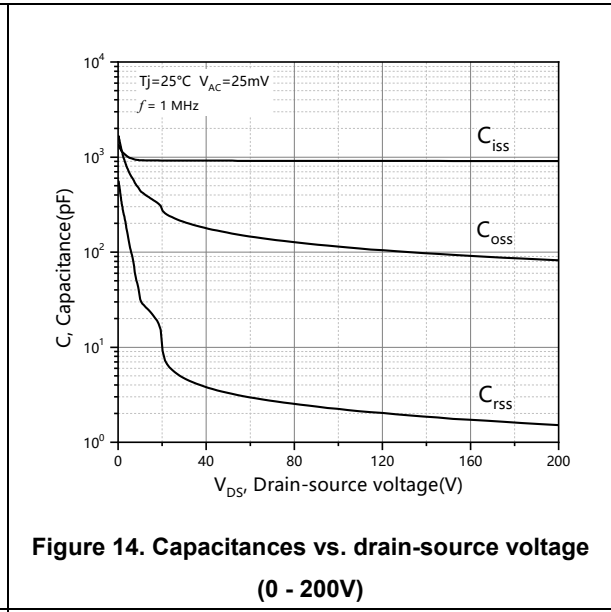
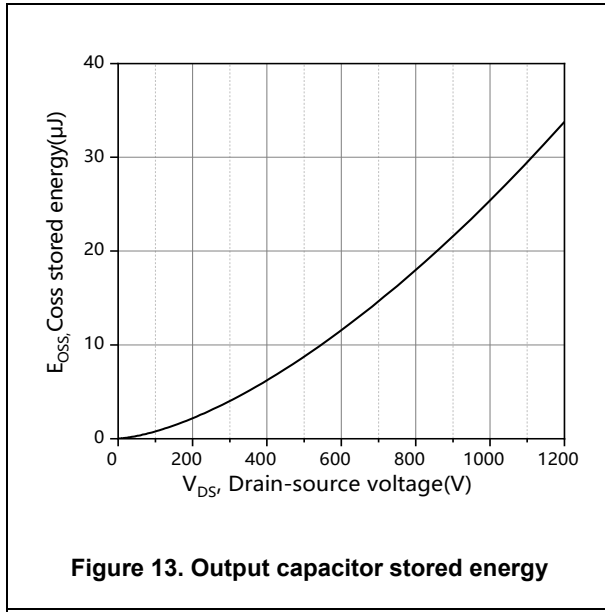
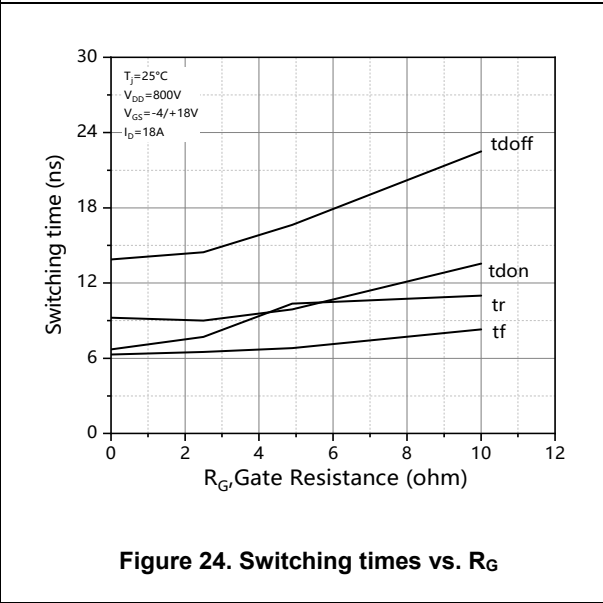
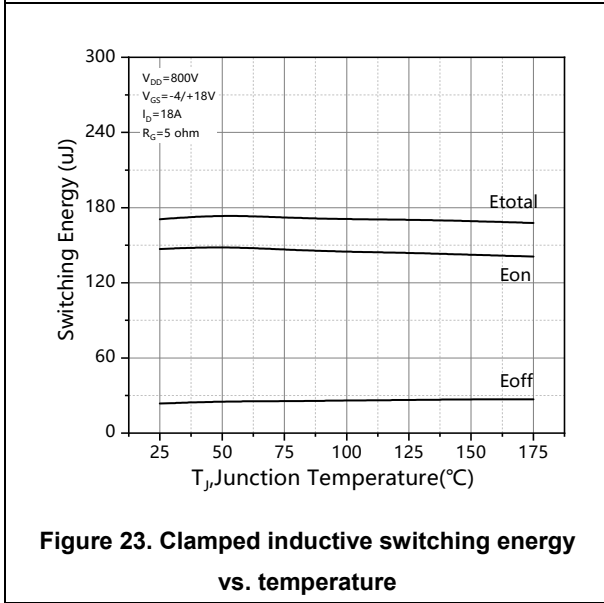
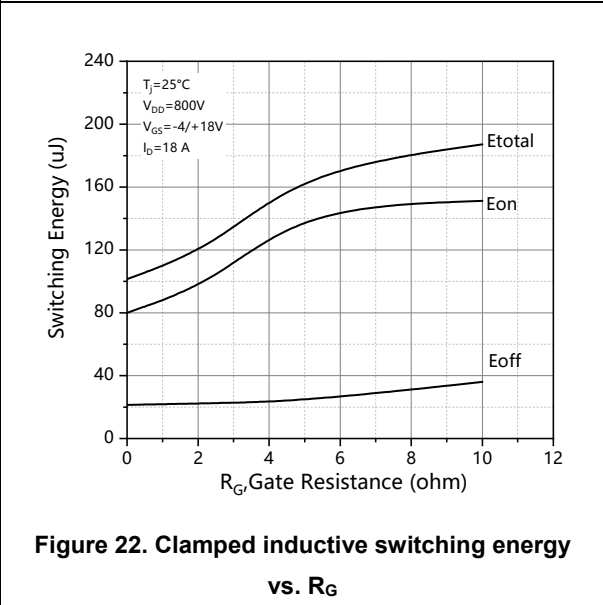
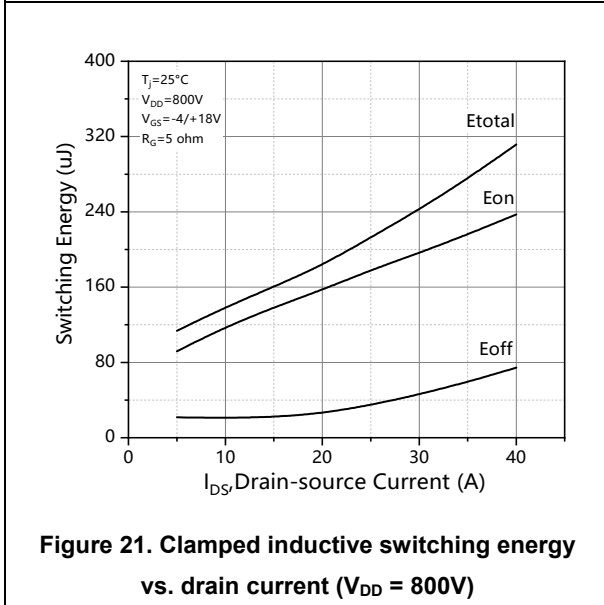
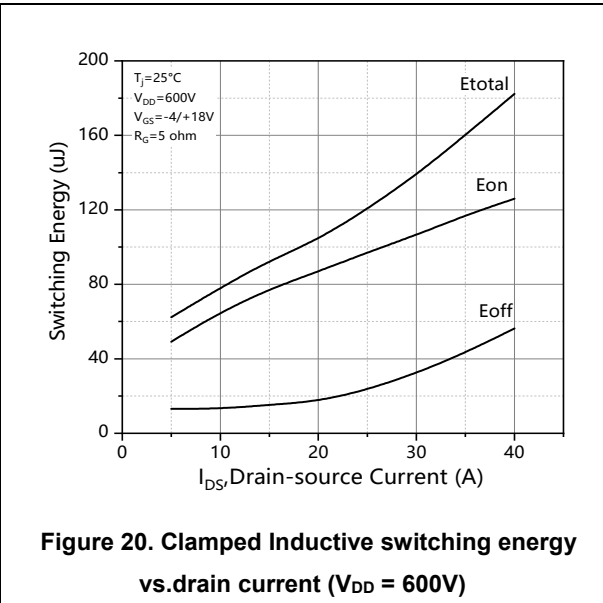
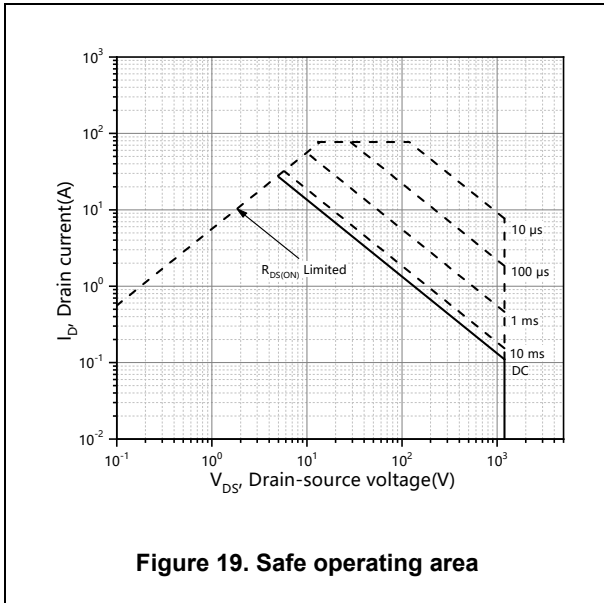
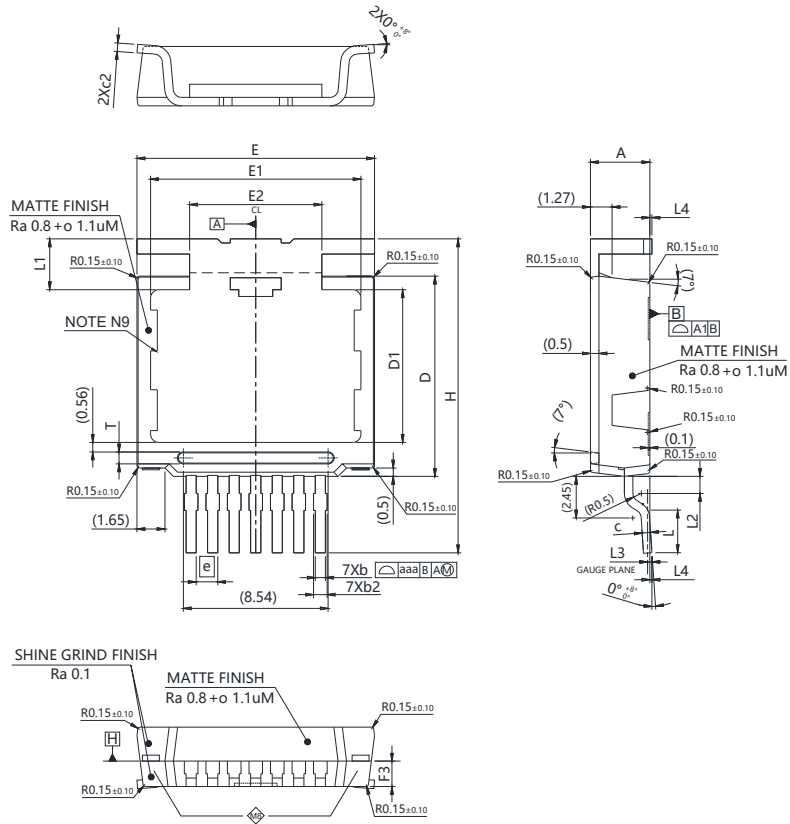

Figure 12. 3rd quadrant characteristic at $T_j = 175\text{ }^\circ\text{C}$





Package Information



| Symbol | mm | | Symbol | mm | |
|--------|-------|-------|--------|---------|-------|
| | Min | Max | | Min | Max |
| A | 3.40 | 3.60 | e | BSC1.27 | |
| A1 | 0.05 | | H | 18.00 | 19.00 |
| b | 0.50 | 0.70 | L | 2.40 | 2.60 |
| b2 | 0.50 | 1.00 | L1 | 3.00 | 3.20 |
| b3 | 0.80 | 1.00 | L2 | 0.90 | 1.10 |
| c | 0.40 | 0.60 | L3 | BSC0.26 | |
| c2 | 0.40 | 0.60 | L4 | 0.07 | 0.18 |
| D | 11.70 | 11.90 | aaa | 0.10 | |
| D1 | 8.90 | 9.10 | F3 | 1.40 | 1.60 |
| E | 13.90 | 14.10 | N1 | 3.80 | 4.00 |
| E1 | 12.30 | 12.50 | N2 | 0.25 | 0.35 |
| E2 | 7.75 | 7.85 | N3 | 0.80 | 1.00 |
| T | 0.60 | 0.70 | b1 | 0.50 | 0.65 |
| c1 | 0.4 | 0.55 | b4 | 0.50 | 0.95 |

Version: T2PAK-S package outline dimension

Ordering Information

| Package Type | Units/ Reel | Reels/ Inner Box | Units/ Inner Box | Inner Boxes/ Carton Box | Units/ Carton Box |
|--------------|-------------|------------------|------------------|-------------------------|-------------------|
| T2PAK-S | 800 | 1 | 800 | 4 | 3200 |

Product Information

| Product | Package | Pb Free | RoHS | Halogen Free |
|-----------------|---------|---------|------|--------------|
| OSQ120R070K9T3F | T2PAK | yes | yes | yes |

Legal Disclaimer

The information given in this document shall in no event be regarded as a guarantee of conditions or characteristics. With respect to any examples or hints given herein, any typical values stated herein and/or any information regarding the application of the device, Oriental Semiconductor hereby disclaims any and all warranties and liabilities of any kind, including without limitation, warranties of non-infringement of intellectual property rights of any third party.

For further information on technology, delivery terms and conditions and prices, please contact the Oriental Semiconductor sales representatives (www.orientalsemi.com).

© Oriental Semiconductor Co.,Ltd. All Rights Reserved 

Revision History

| Version | Revision History | Date |
|---------|------------------|------------|
| V1.0 | Initial release | 2026-01-21 |